

EMCO F1-CNC

Basic

Preface

The use of CNC-machines will still increase in the future.

Not only in industrial production also in small workshops conventional machines will be replaced by CNC-machines.

The application of CNC-technics is not bound to the classic machine tools such as lathes, milling machines or to the metalworking area. One could say, nearly every day a new application of CNC technics is realized. Practically all occupations such as technical designer, technical manager or salesman, skilled worker, methods engineer, controller, etc. will be confronted with CNC-technology in many ways.

CNC basic knowledge is important for everyone of them. How specialized this knowledge must be, will depend on the specific occupation.

EMCO MAIER & CO. is also producer of CNC production machines and since a long time experienced and active in technical education worldwide.

After producing the EMCO COMPACT 5 CNC which is used worldwide successfully for years, the EMCO F1-CNC has been developed.

As the method and the concept of the EMCO COMPACT 5 CNC has been very successful, we designed the F1-CNC also that way: the student should work on the machine from the very first hour.

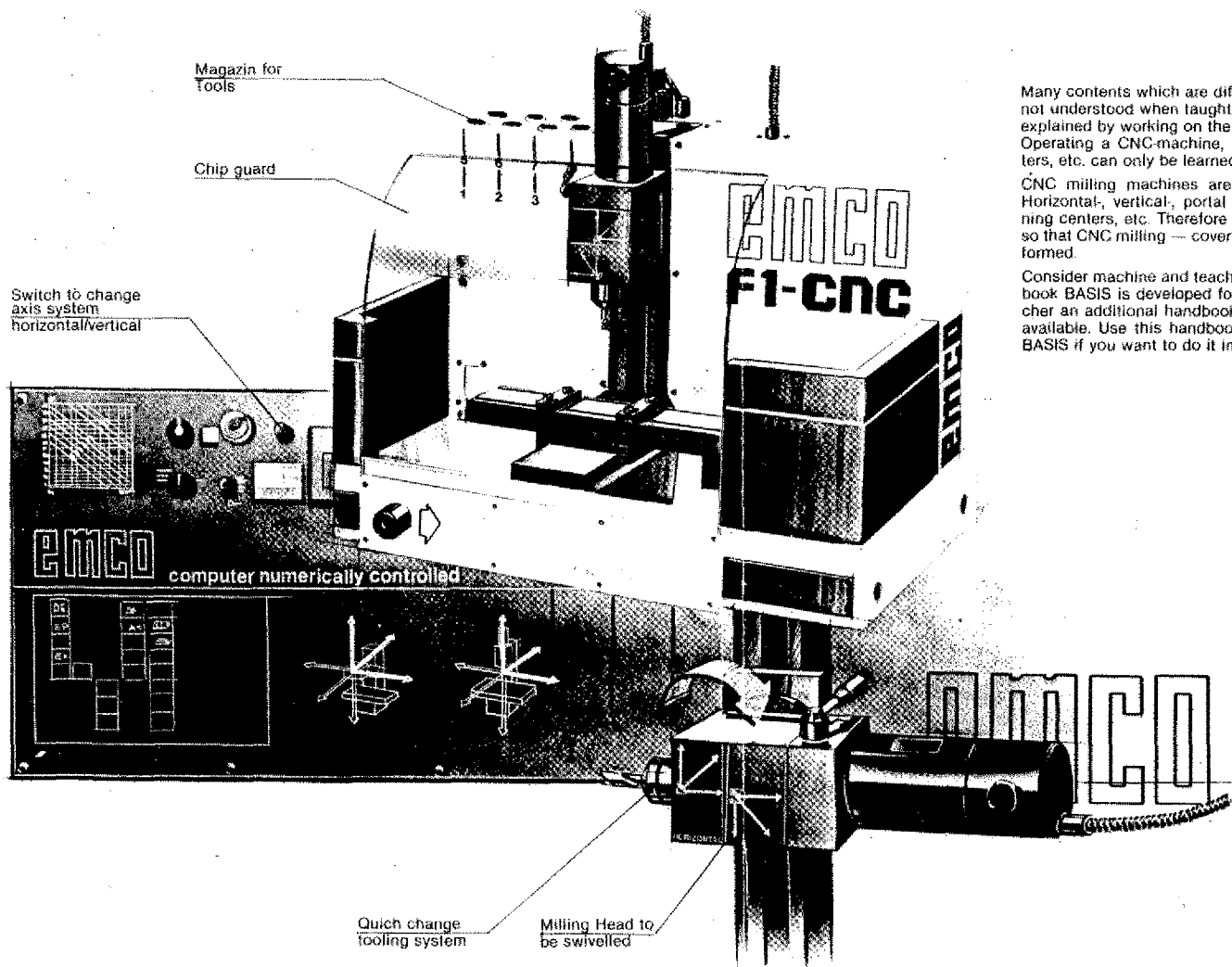

Many contents which are difficult to explain and often not understood when taught theoretically, can only be explained by working on the CNC-machine. Operating a CNC-machine, milling with different cutters, etc. can only be learned by practical working.

CNC milling machines are built in different types: Horizontal-, vertical-, portal milling machines, machining centers, etc. Therefore we designed the machine so that CNC milling — covering all types — can be performed.

Consider machine and teaching material as a unit. The book BASIS is developed for the student. For the teacher an additional handbook and Overhead slides are available. Use this handbook in addition to the book BASIS if you want to do it in a self-teaching course.

All rights reserved especially those of diffusion and duplication through film, radio, television, photomechanical reproduction, sound tracks of any and every kind, translation into foreign languages, reprints of, extracts from the text.

© 1984 by EMCO MAIER & CO., Fabrik für Spezialmaschinen, Friedmann-Maier-Straße 9, A-5400 Hallein, Austria.

Printed in Austria.

1. General

- Technological data**
- Finding the Chip Removal Values, Speeds**
- Mounting the Tools**
- Chucking the Workpieces**

Technological data

1. Cutting speed (V_s)

$$V_s \text{ (m/min)} = \frac{d \text{ (mm)} \times \pi \times S \text{ (rpm)}}{1000}$$

V_s = Cutting speed

d = Diameter of workpiece

S = Main spindle speed

The maximum cutting speed depends on

- Material of workpiece:

The higher the resistance of the material, the lower the cutting speed.

The charts contain the following data:

V_s = 44 m/min for aluminium (Torratur B)

V_s = 35 m/min for soft steel
soft plastics

V_s = 25 m/min for tool steel
hard plastics

- Material of tool:

Carbide tools allow higher cutting speed than HSS tools.

Values given in the charts are for HSS tools.

2. Spindle speed (S)

You calculate the speed of the milling spindle from cutting speed and diameter of milling cutter.

$$S \text{ (rpm)} = \frac{V_s \text{ (m/min)} \times 1000}{d \text{ (mm)} \times \pi}$$

3. Feed Rate and Depth of Cut

F = Feed rate (mm/min)

t = Depth of cut (mm)

Generally: feed rate and cutting speed depend on:

- workpiece material
- performance of machine and
- geometry of milling cutter.

Material of workpiece

The higher the material resistance the larger the feed and the depth of cut (limitation by milling cutter geometry).

The charts contain orientation values for the F1-CNC.

Connection $F - t$

The larger "t" the smaller "F" and vice versa.

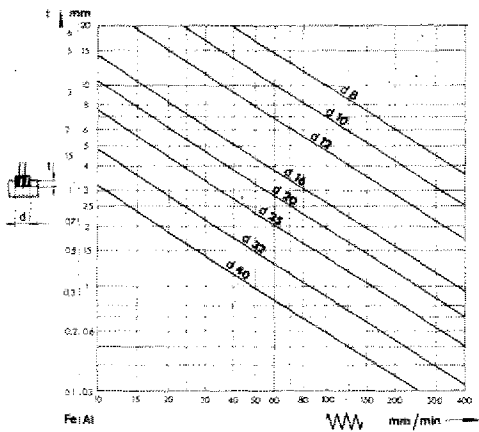

Procedure

The technological data are written into the tool specification sheet.

Finding the feed rate and the depth of cut:

Material: aluminium

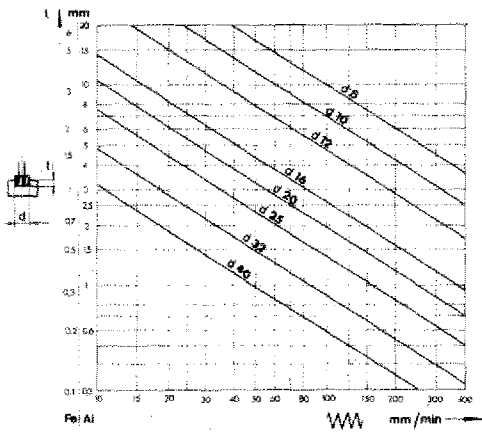
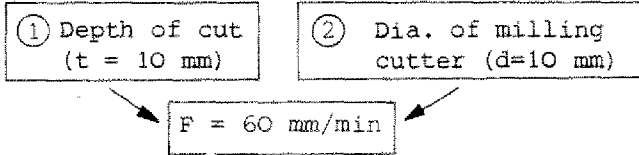

You can also proceed in a different way:

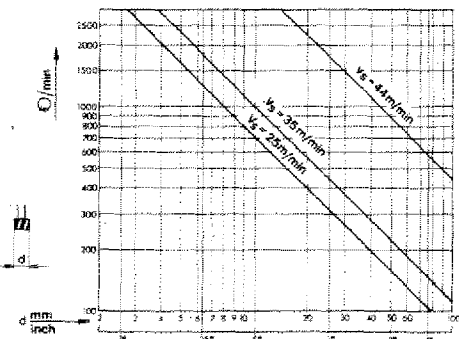
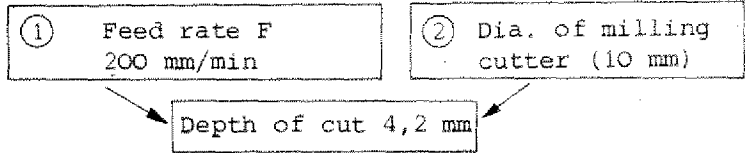

Finding the speed of rotations:

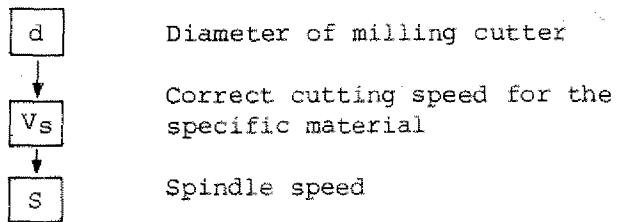

The same procedure applies for drilling.

PS: Downcut milling - Conventional Milling

The specific knowledge is presupposed. However, with the F1-CNC the differences may be neglected.

Milling

Depth of cut - Cutter diameter - Feed

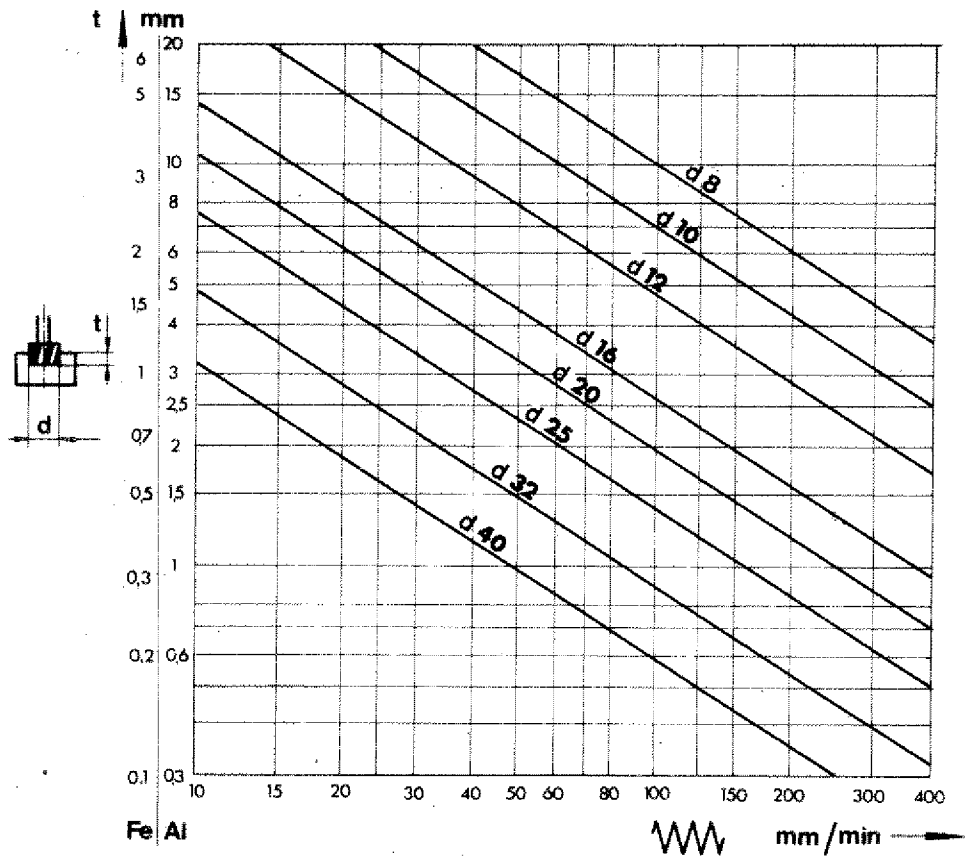

Drilling

Diameter of drill bit - Feed

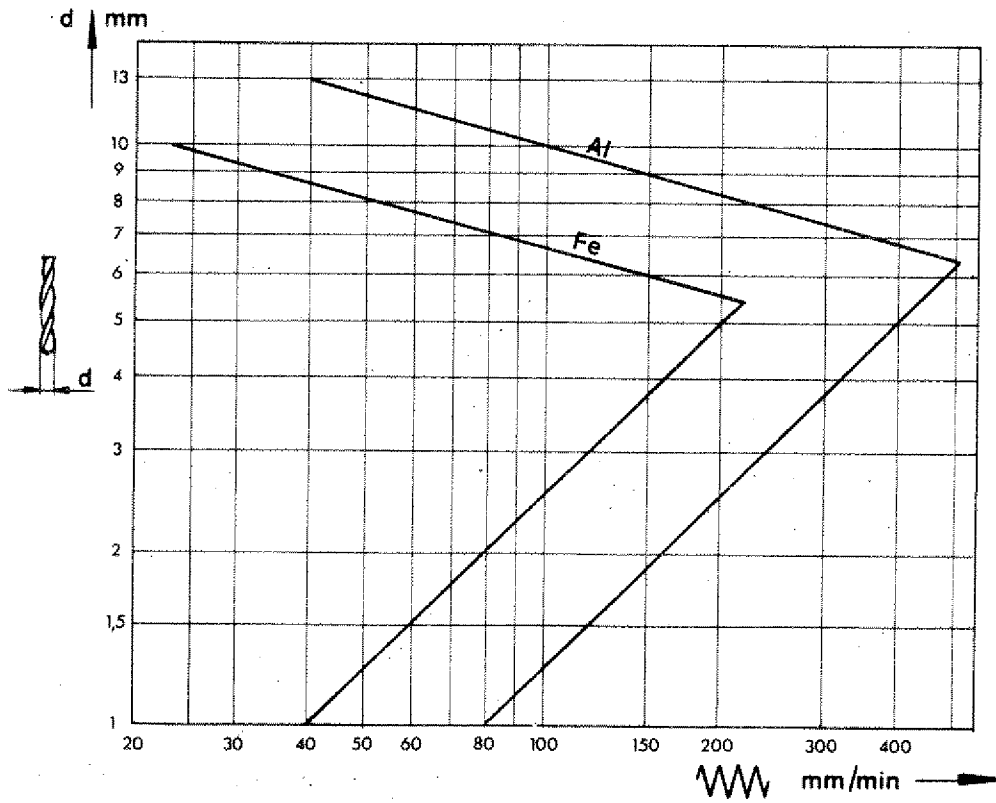

Speed (of rotation) — Cutting speed — Feed

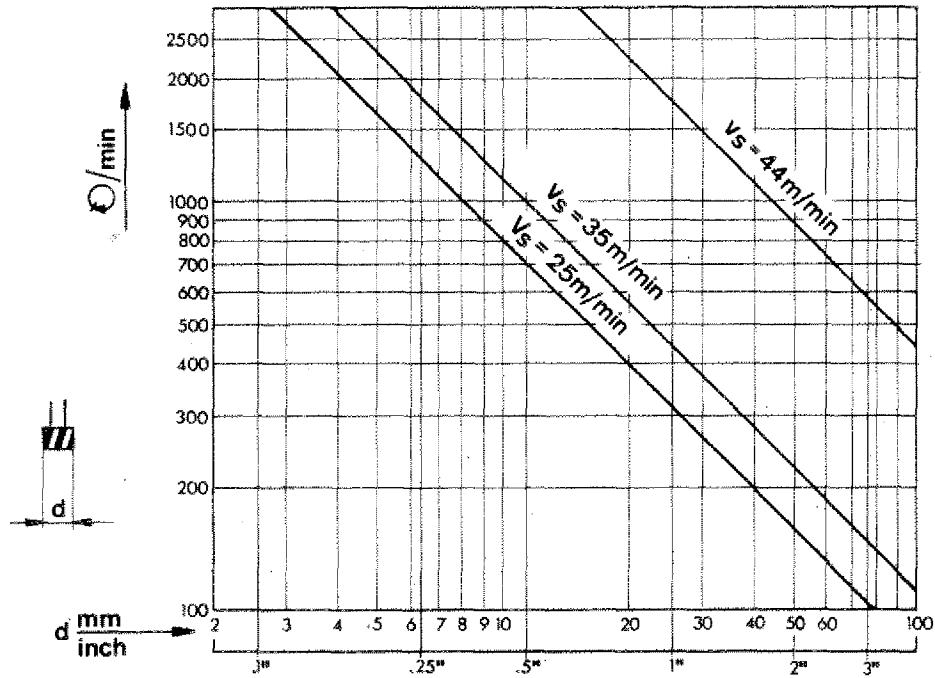

Attention:

When plunging in with cutter, halve feed values of mill chart.

Service and Maintenance of Machine

Lubrication:

Lubricate guideways of longitudinal, cross and vertical slide daily using oil gun (1 nipple on vertical slide, 2 nipples left side underneath longitudinal slide).

Pressure resistant, corrosion-protective oil with slip-stick reducing characteristics.

73 mm/sec (cSt) reference temperature 40° C.

E.g. CASTROL MAGNA BD 68
This corresponds to the CINCINNATI Specification P47.

Spindle taper for tool mounting

Interior taper of main spindle and tool taper have to be free of grease and dust (force locking)!

Safety measures

Pay attention to the general and specific milling safety rules. The knowledge about them is pre-supposed.

Raw material

If you use aluminium, take only machinable aluminium.

Advisable material:

Torrador B, Al, Cu, Mg, PB F38, material no. 3.1645.51 according to DIN 1725/1747 or similar.

Tools

Use high quality and well sharpened tools only.

Clamping of Tools

Attention:

Spindle taper and tool taper must be dirt- and dust-free.

Clamping with collet chuck

Tools with cylindrical shaft are clamped with the collet chuck.

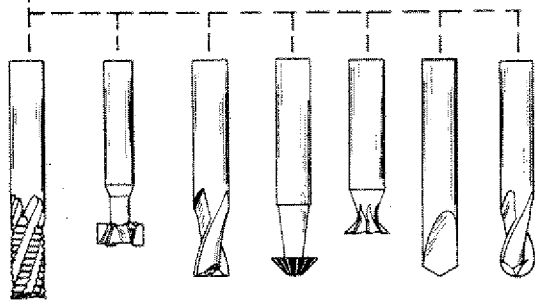
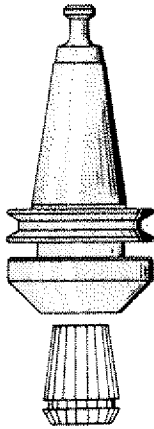

Note:

- Put collet into nut inclined so that the eccentric ring grips the groove of the collet. Screw nut with collet onto collet chuck.

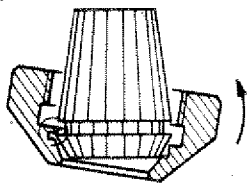

Clamping of tools

Put tool into collet and tighten nut with cylindrical pin in clockwise direction. For counter-holding of main spindle put cylindrical pin into collet holder.

Taking out the collet:

Unscrew nut. The eccentric ring in the nut presses the collet out when unscrewing.

Maintenance

Use oil and clean collet and collet chuck after use. Chips and dirt can damage the tapers and influence the precision.

Collets

You find the clamping capacity in inch and metric engraved on the collets. Diameters smaller or larger than indicated must not be clamped.

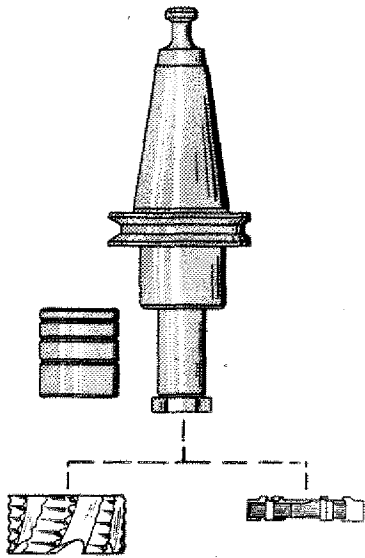

Clamping with shell end mill arbor

Using the arbor you can clamp tools up to a bore of 16 mm. The 4 spacing collars serve for adjusting the different width of the milling cutters.

Clamping Possibilities for Workpieces

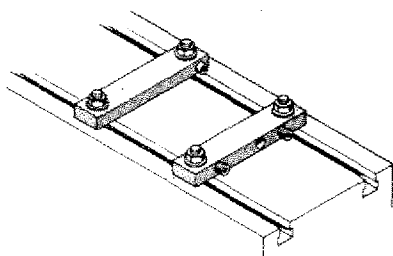

Clamping bars

The clamping bars are mounted directly onto the slide depending on the relative workpiece.

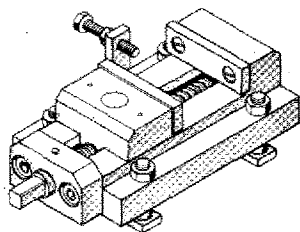

Machine vice with stop

Width of jaw: 60 mm

Clamping capacity: 60 mm

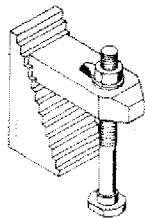

Stepped clamping shoe

Height: 60 mm

For clamping a workpiece you need at least two clamping shoes.

3-jaw chuck (2 × 3 Jaws)

For holding of round, triangular and hexagonal workpieces centrally.

4-jaw chuck (2 × 4 jaws)

For holding of round, square and octogonal workpieces centrally.

4-jaw independed chuck

For holding of workpieces centrally and eccentrically.

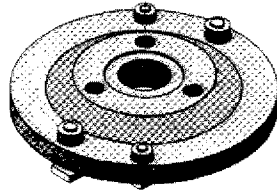
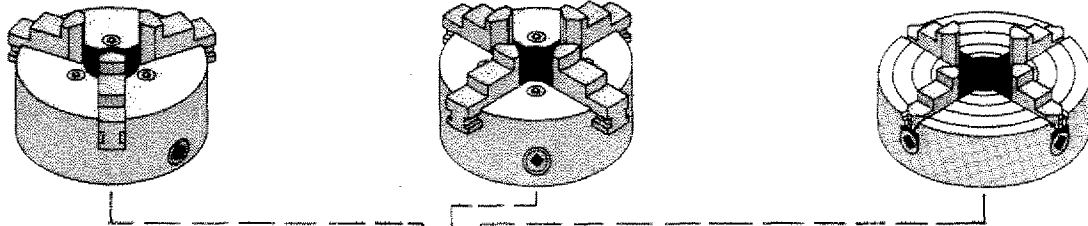

Adaptor plate

To mount 3-jaw, 4-jaw chuck and independent. The adaptor plate itself is mounted on to the milling table.

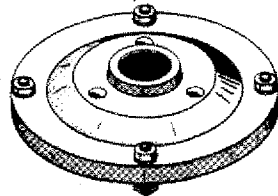
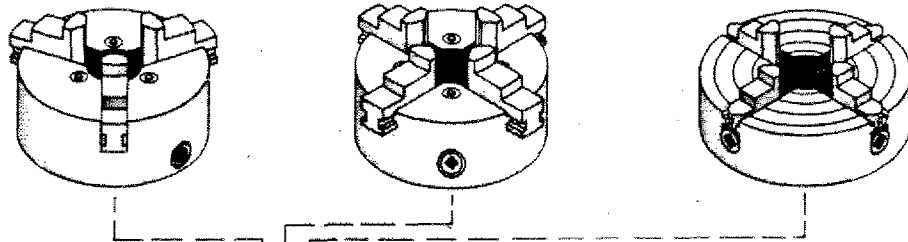

Intermediate plate

To mount 3-jaw, 4-jaw chuck and independent. The intermediate plate itself is mounted on to the dividing attachment. The dividing attachment is clamped to the milling table with two T-nut screws.

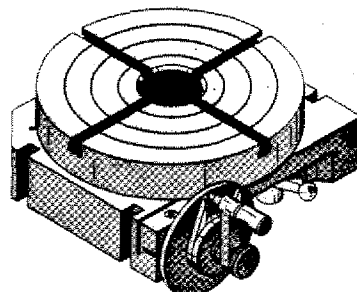

Dividing attachment

The Dividing Attachment

Operating tips

TECHNICAL DATA

Diameter of rotary table: 150 mm

Worm reduction: 1:40

T-slots according to factory standard

Number of holes in dividing plates:
27, 33, 34, 36, 38, 39, 40, 42

OPERATING ELEMENTS

Clamping levers for rotary table (1):

Clamping levers are loosened during the dividing operation itself, but must be clamped before every machining operation.

Indexing pin with handle (2):

During direct dividing from 15° to 15° , the pin rests into the parameter notches of the rotary table. During indirect dividing (worm dividing) or free dividing by means of the graduated scale, the indexing pin must be pulled out and swivelled to the left.

The graduated scale (3) is for controlling the divisions.

Crank handle with index plunger (4) moves the worm which is engaged with the wormwheel of the rotary table during indirect dividing.

The shears serve to facilitate adding the number of holes when a fraction of a turn is to be added.

Disengaging and engaging the worm:

The allen head screw (5) is loosened. When the dividing plate is turned counterclockwise, the worm and wormwheel are disengaged. The rotary table can be turned by hand for direct indexing. By turning the dividing plate clockwise, worm and wormwheel are engaged. To facilitate engagement of worm and wormwheel, the rotary table should be moved slightly by hand.

The allen head screw (5) must again be retightened.

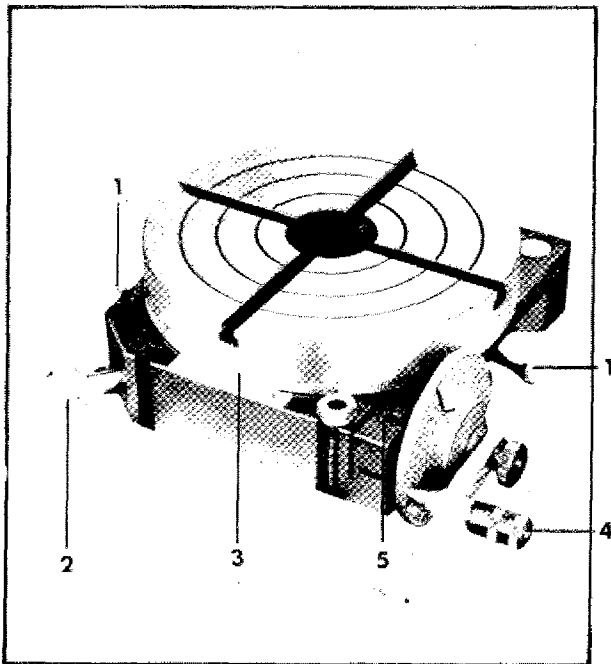

T-slots of the dividing attachment

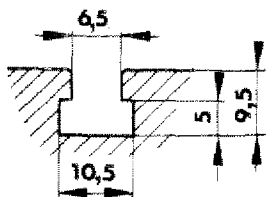

Types of Dividing

Indirect dividing:

Indirect dividing offers many more dividing possibilities and is more accurate because of the worm reduction of 1:40.

Indirect dividing method:

If the crank handle is turned 40 times, the rotary table makes 1 revolution (360°). With help of the dividing plates, exact fractions of turns can be executed.

Direct dividing:

Worm and wormwheel are disengaged.

Possibility 1:

Dividing by means of the indexing pin. Dividing possibility from 15° to 15° (i.e., maximum of 24 divisions within 360°).

Possibility 2:

The dividing can be done freely with the aid of the graduated scale on the rotary table.

Note

With indirect dividing the indexing pin is always disengaged. For manufacturing a workpiece the rotary table has to be fixed.

The indexing chart:

1st column: indicates number of divisions per 360°

2nd column: shows the corresponding angle of the division

3rd column: shows the number of 360° crank handle revolutions which are necessary

4th column: shows the number of holes to be added for each index plate

Example of an indirect dividing operation:

Desired division: 13 divisions in 360°

From the indexing table it can be seen that at the desired division 13, 3 full crank turns must be made plus a fraction turn of 3 additional holes on the indexing plate 39.

Practical execution:

1. The indexing plate with 39 holes is mounted.

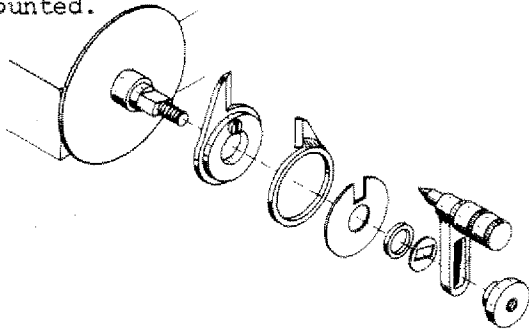

2. in the indexing table one sees that at the division 13, 3 full turns plus 3 holes on the 39 plate have to be added. Therefore, the shears are fixed so that they include 4 holes.

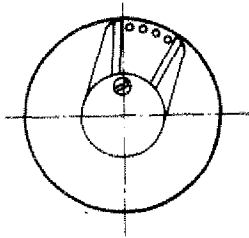

3. The indexing plunger is placed in a hole of the 39 plate (marked black on the drawing) and the left shear arm moved until it touches the pin of the plunger.

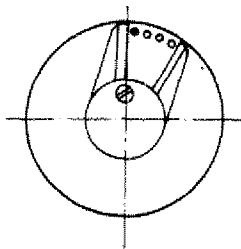

4. Execution of the dividing operation: 3 full turns plus the fractional turn of the 3 added holes are made; that means that the plunger is placed in the black hole. One dividing operation is completed.

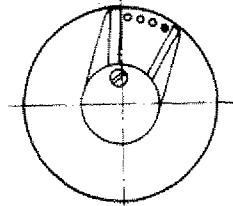

5. Next dividing operation: The shears are turned until the left arm touches the pin again; the next dividing operation follows as described in 4. above.

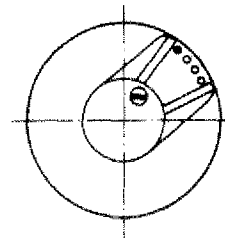

NOTE: The shears may not be moved during the dividing operation, otherwise they do not serve their purpose as an orientation aid.

NOTE: If a larger number of holes has to be reached than the maximum opening of the shears allow, you have to set the difference of holes between the shears.

Example

21 divisions per 360° have to be carried through. From the chart one can see that one full turn plus the fractional turn of 38 holes on the disc 42 have to be carried through. 38 holes cannot be set.

Thus: $42 - 38 = 4$ holes. When dividing you make one additional turn (2 turn altogether) and turn back the difference of 4 holes (the shears comprise 5 holes).

**INDEX TABLE
for
MAXIMAT**

Formula for the Calculation of the Hole Numbers Required
 z = No. of divisions required for one revolution of the workpiece.
 K = No. of revolutions of handle for a complete revolution of the workpiece.
 n = No. of revolutions of handle for one dividing move: $n = \frac{K}{z}$
 Worm reduction of dividing head 1:40; i. e. $K = 40$.

Division Desired	Degrees	No. of crank turns req'd	Amount of holes to be added for each index plate								Division Desired	Degrees	No. of crank turns req'd	Amount of holes to be added for each index plate							
			27	33	34	36	38	39	40	42				27	33	34	36	38	39	40	42
2	180°	20								32		1			9			10			
	175°	19	12							33		1	7								
	170°	18	24							34		1		6							
	160°	17	21							35		1							6		
	150°	16	18							36	10°	1	3		4						
	140°	15	15							38		1				2					
	130°	14	12							39		1					1				
	125°	13	24							40	9°	1									
3	120°	13	9	11		12		13		42									40		
	110°	12	6							44				30							
	100°	11	3							45	8°		24			32					
4	90°	10								48					30				35		
	80°	8	24							50								32			
	75°	8	9	11		12		13		50	7°		21		28						
5	72°	8								52							30				
	70°	7	21							54			20								
	65°	7	6							55				24							
6	60°	6	18	22		24		26		56									30		
	55°	6	3							60	6°		18								
7		5							30	64								25			
	50°	5	15							65							24				
8	45°	5								66				20							
9	40°	4	12			16				68					20						
10	36°	4								70									24		
11		3		21						72	5°		15			20					
12	30°	3	9	11		12		13		76						20					
13		3						3		78							20				
14		2							36	80					17	18	19		20		
	25°	2	21							84									20		
15	24°	2	18	22		24		26		85				16							
16		2			17	18	19		20	88				15							
17		2			12					90	4°		12		16						
18	20°	2	6			8				95					16						
19		2					4			96					15						
20	18°	2								100									16		
	16°	1	21							120	3°		9	11		12		13	14		
21		1							38	180	2°		6		8						
22		1		27						200								8			
24	15°	1	18	22		24		26		240					6				7		
25		1							24	270			4								
26		1						21		360	1°		3								
27		1	13								40'		2								
28		1							18		30'				2						
30	12°	1	9	11		12		13			20'		1								

Chapter 2: Handoperation

- Operating element (survey) 2.2**
- Positioning of milling cutter 2.4**
- Traverse indication 2.7**
- Input of X, Y, Z values 2.8**
- Switching feed motors
"Curventless" 2.11**

Traverse — Hand Operation

Display

After switching on the machine, the figure 0 appears. Lamps X, Y or Z are on.

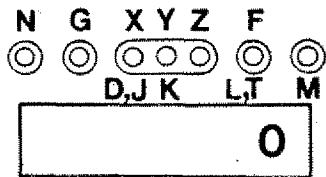

If you traverse in $\pm X$, the lamp X lights up. When you take your finger from the key, the traverse distance is shown in 1/100 mm on the VDU. With a distance of 2,45 the display indicates 245.

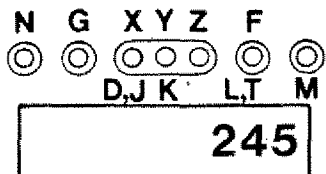

If you press the Z-key, the light jumps to the Z-lamp. After you lift your finger from the key, the traverse distance appears (with 6,28 mm 628 will appear)

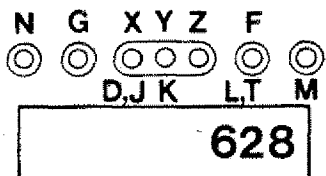

Minus sign on display

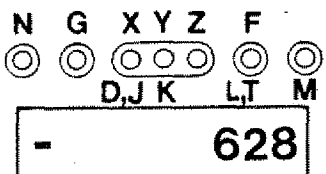

Monitor

The screen shows zero for X, Y, Z when you switch it on.

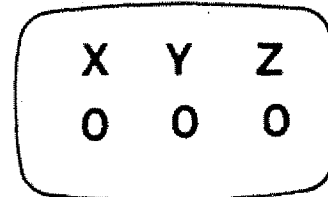

With the exception of rapid traverse the indication is shown continuously in steps of 0,5 mm.

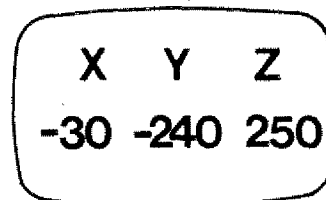

Input of X, Y, Z Zero-Values from any chosen Milling Position

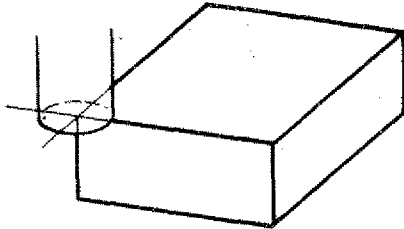

The display should indicate zero, in case the milling cutter stands at a given point ($X=0$, $Y=0$, $Z=0$).

You can program the X,Y,Z displays to indicate zero.

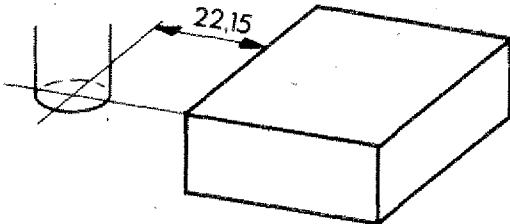

The milling cutter is at a distance of 22,15 mm to the workpiece edge in X. The display indicates whatever value.

In case the milling cutter traverses in +X direction by 22,15 mm, then the display should indicate the value $X=0$.

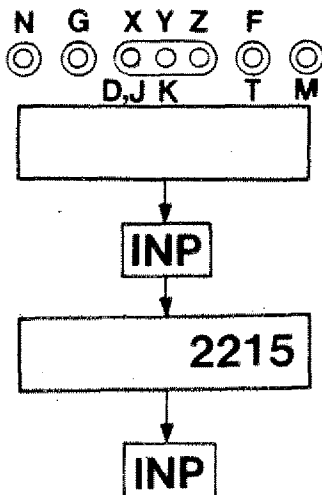

Procedure:

1. The lamp X on the display lights up
2. Press INP - the lamp X flashes
3. Put in the value 2215 (no plus/minus sign, because the milling cutter should indicate with plus "traverse direction 0").
4. Press key INP. The flashing of the X-lamp stops.

You can enter the Y,Z values in the same way.

When programming minus-values first put in the figures, then press key minus.

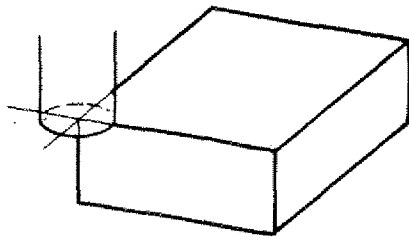

Application of Path Programming in Hand Operation Mode

Zero point for the dimensioning is the workpiece edge. The milling cutter shall move to this point. The displays shall be set zero.

Procedure:

1. Scratch surface, set Z-display zero.

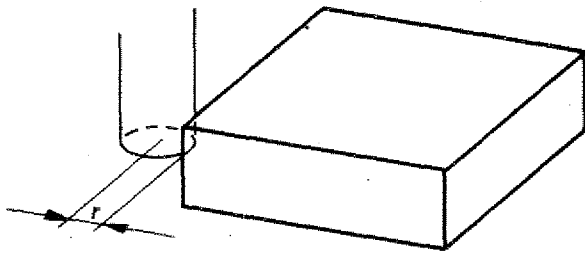

2. Scratch surface in X-direction. Put in value of milling cutter radius r .

3. Scratch surface in Y-direction. Put in value of milling cutter radius r .

Note:

You can traverse after scratching as you like. If you program the zero-point, you have to add to the X,Y display the radius value and put it in.

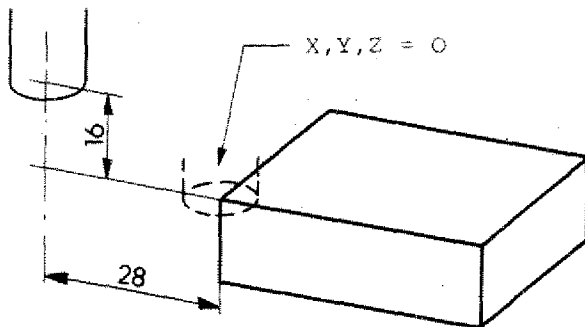

Exercise:

1. Program the display $X,Y,Z=0$ if the milling cutter is positioned onto the edge.
2. Move the milling cutter to the indicated position.

Switching Feed Motors "Currentless"

When switching on the machine the feed motors are currentless.

If you have - in hand- or CNC-operation mode - moved the slides the feed motors stay under power.

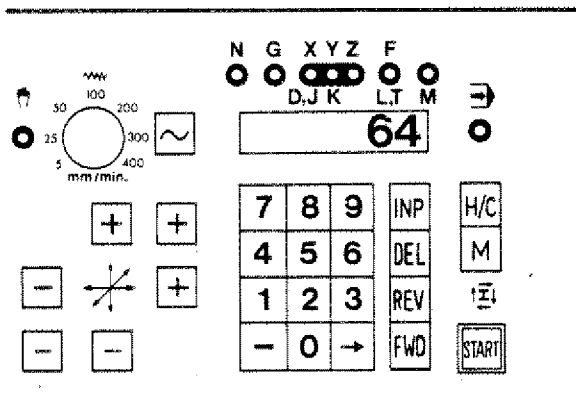

Switching currentless - with no program being stored

1. Switch to CNC-operation mode: Press **H/C** key.
2. Press key **→**. The light jumps to G.
3. Key in **64**. The number appears on the VDU.
4. Press key **INP**. Now the feed motors are switched currentless.

Switching currentless - with a program being stored

G64 is a pure switching function. It is not stored.

1. Press key **→** so that G light gets on.
2. When a number appears on the VDU, press **DEL**.
3. Key in **64**.
4. Press key **INP**. Now the feed motors are switched currentless.

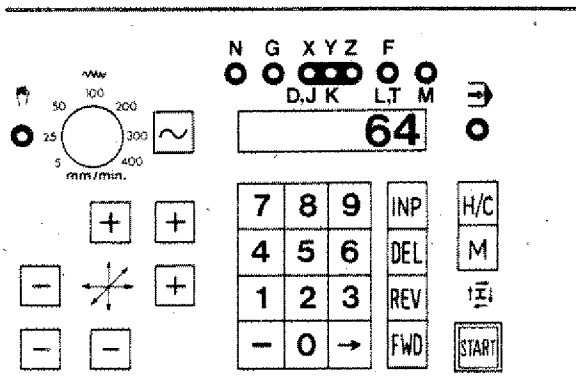

Operating Elements Control Elements Hand Operation

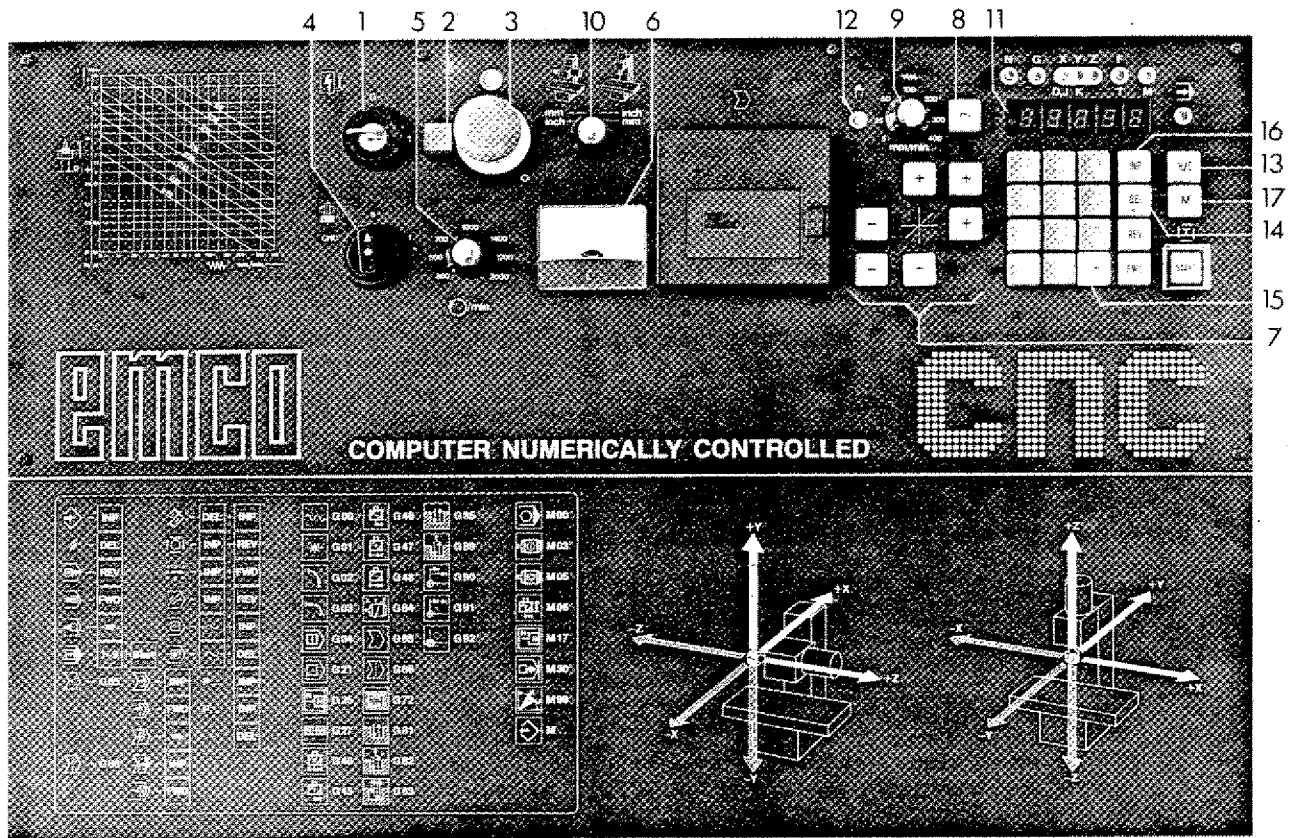

1. Main switch

Turn key to the right. Machine and control part are under power (except emergency stop button is pressed).

2. Control lamp main switch

When main switch is on, lamp is on.

3. Emergency stop button

Control unit, feed motors and main motor are cut off from power by pressing emergency stop button: turn button to the left - it will jump back to original position. Main switch has to be switched on again.

4. Switch for main spindle

Turn switch to the right.

5. Turning knob for speed control of main spindle

6. Ammeter

Shows power consumption of main spindle motor. In order to protect motor against overload, the power consumption should not surpass 2 A with 220-240 V or 4 A with 100-110 V.

7. Feed keys for longitudinal, cross and vertical slide

8. Rapid traverse key

If keys for feed and rapid traverse are pressed together, then the relative slide will move with rapid traverse speed.

9. Turning knob for setting the feed rate

10. Inch/metric switch and switch for changing the axis system

11. Digital read-out for slide movement

$\pm x$, $\pm y$, $\pm z$ are shown in 1/100 mm or 1/1000 inch.

Plus movement without sign
Minus movement by a light beam

- 125

X -1,25 mm or -0.125 inch

12. Control lamp for hand operation

13. **H/C** switch key: hand operation/CNC operation

If you press the **H/C** key the light of the control lamp hand operation will jump to CNC operation (operation mode: CNC). By pressing the key once again the light will jump back (operation mode: hand operation).

14. **DEL** key

The X,Y,Z values are set to zero.

15. The **→** key

With the **→** key you can switch from X to Y to Z without movement of slides.

16. The **INP** key

With the **INP** key you enter the values for slide movements.

17. M-key

Activates switching exits.

Hand Operation F1-CNC

Positioning of the Milling Cutter

1. Scratching front sides and top side

With milling most measurements refer to outer edges. In order to use the measurements of the technical drawing you have to "zero-set" the display and use as reference/starting point the outer edges.

Example

Milling cutter with dia. 10 mm.

Move milling cutter in Z-direction until you scratch surface slightly.

Set Z-display to zero (press key DEL).

X	Y	Z
0	0	0

- Scratch front side in X-direction.
- Set X-display to zero (press key DEL)

X	Y	Z
0	0	0

- Scratch front side in Y-direction.
- Set Y-display to zero (press key DEL)

X	Y	Z
0	0	0

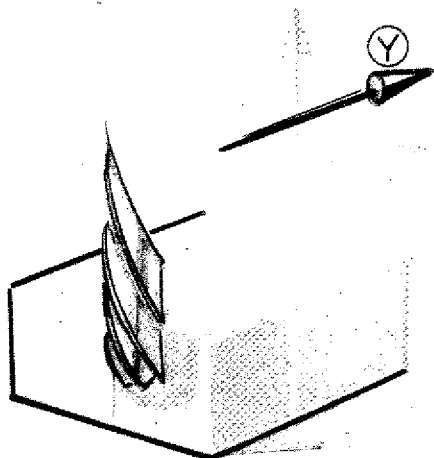
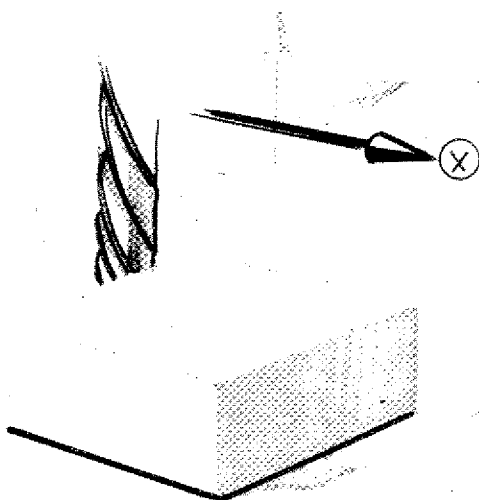
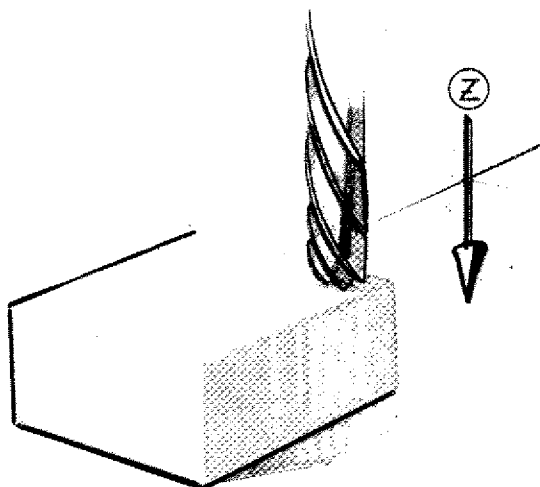

2. Zero-setting of Display to Zero Point of Dimensioning (Example: Milling)

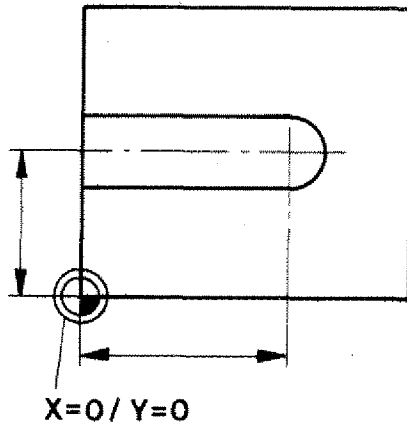

Example: Milling of groove

- The groove is milled using a 8 mm cutter.
- Zero point for the dimensioning is the workpiece edge and surface.
- The measures refer to the center of the milling cutter.

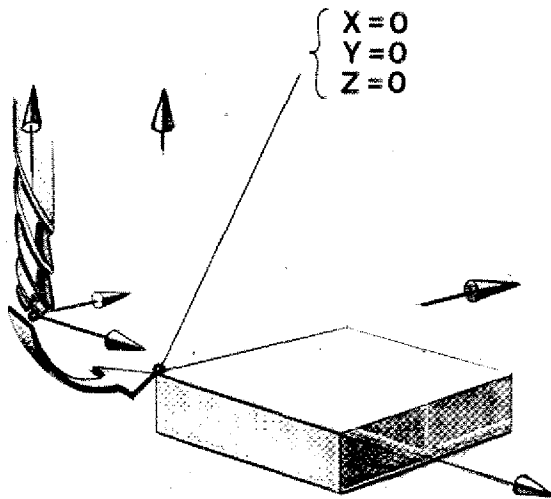

Consequence

Move axis of milling cutter to edge of workpiece.

- a) Scratching of all 3 surfaces and zero-setting of X,Y,Z.



400

DEL



0

- b) Move by value of milling cutter radius into X-direction. Set X to "zero".

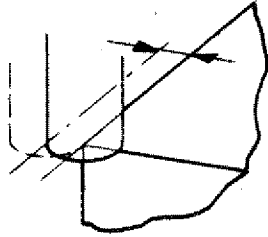

c) Move mill cutting by value of milling cutter radius into Y-direction. Set display to "zero".

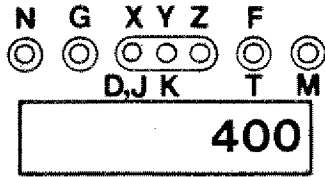

DEL

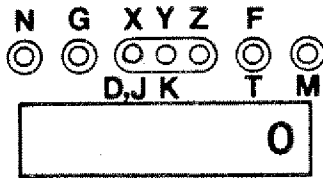

Exercise

Move milling cutter such that all display values are at "zero".

Exercise

Mill a recess as in drawing. Enter the following values:

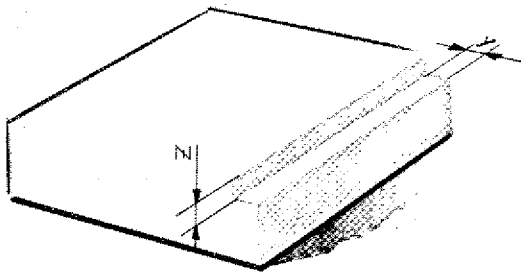

Spindle speed S (rpm)	
Feed mm/min	
Infeed in X (mm)	
Infeed in Z (mm)	

Pay attention to set correct feed.

Chapter 3

CNC-Operation – Survey

— Operating and control elements	3.2 – 3.3
— Preparatory functions, miscellaneous-/Switching functions	3.4 – 3.5
— Alarm signs	3.6
— Possible inputs	3.7
— Operation CNC Operation magnetic tape	3.9

Operating Elements Control Elements CNC-Operation

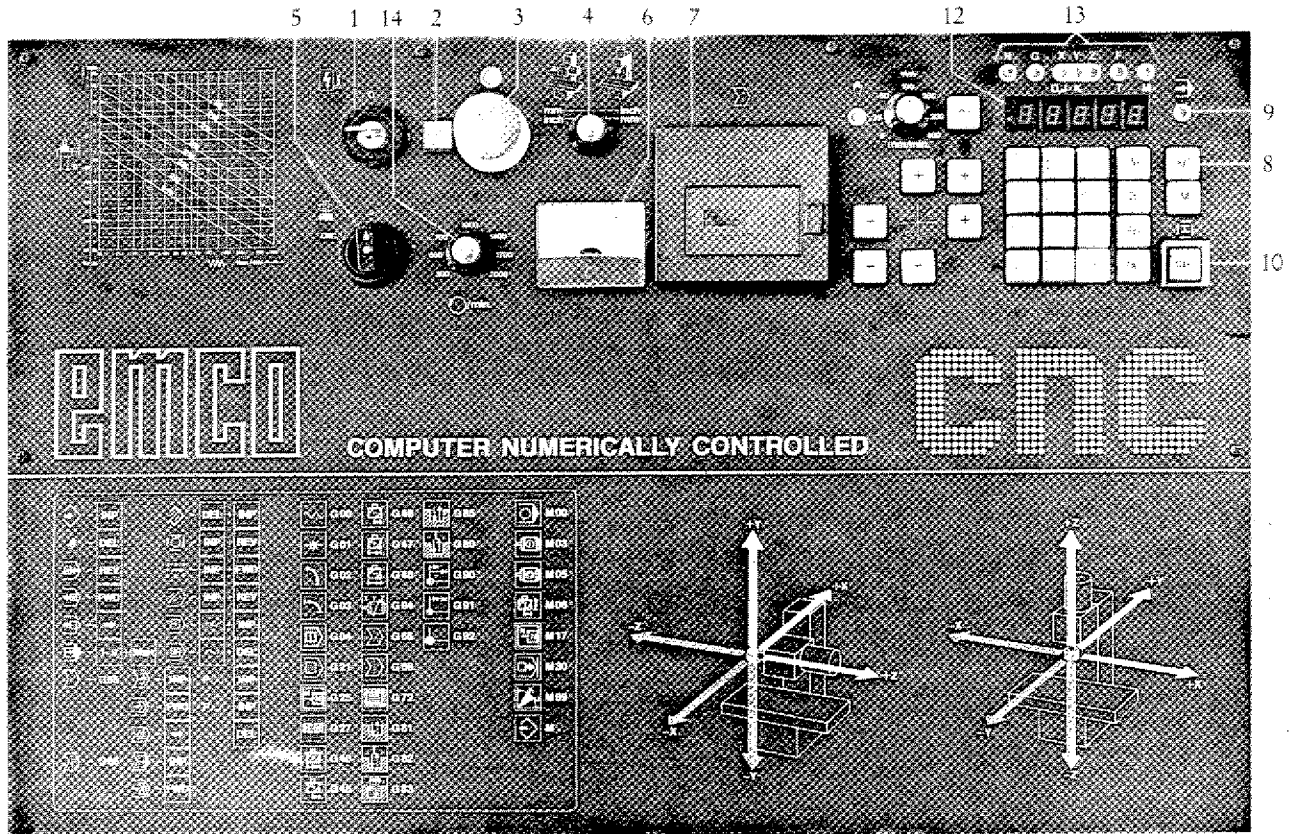

1. Main switch with removable key. Memory is being cleared when switching off.
2. Control lamp shows the power supply of machine and control unit.
3. Emergency stop button with interlock. Unlocking of button: turn button to the left. To switch on machine, turn main switch to zero and to 1 again. When switching off also memory will be cleared.

4. Optional switch for axis system and for metric or inch mode of operation.

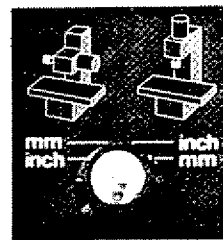

5. Switch for main spindle

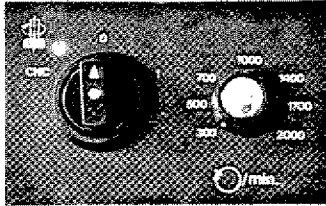

Position 1 (main spindle ON, without MO3)

Position CNC: main spindle is switched on by programming MO3 and switched off by MO5, MO6 (with F#O) and M30.

6. Ammeter

7. Magnetic tape

8. **H/C** switch key
Manual/CNC operation

9. Control lamp CNC operation

10. **START** key
The program is being worked off

12. VDU (display):
Indicates values for address letters and modes of operation

13. Control lamp address letters

14. Control of milling spindle speed

11. Keys for program input, correction, storing of program on tape, V24 operation etc. (see detailed explanations)

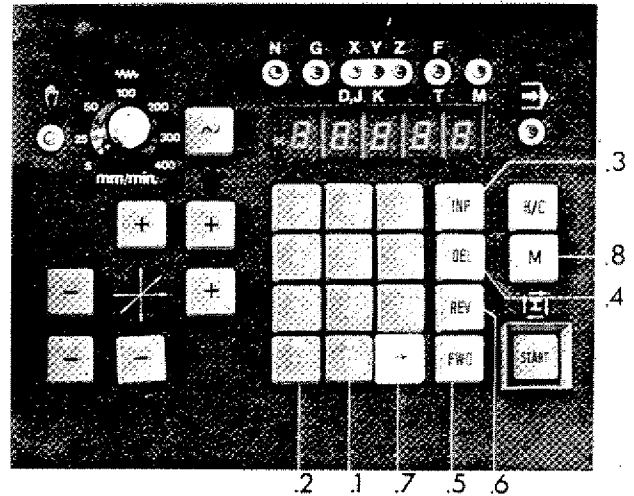

11.1. Number keys **0** - **9**

11.2. **-** The minus sign key
To enter minus values the minus sign **-** has to be pressed after input of numbers.

11.3. **INP** key (INPUT = storing)
Storing key

11.4. **DEL** key (DELETE = erase)
Erasing key

11.5. **FWD** key (FORWARD)
Program jumps forward block by block

11.6. **REV** key (REVERSE)
Program jumps backwards block by block

11.7. **→** Arrow key
Display jumps word by word

11.8. **M** key: key for entering of miscellaneous functions.

Survey

Preparatory Functions, G-Codes

G00 Rapid traverseV: N3/G00/X[±]5/Y[±]4/Z[±]5H: N3/G00/X[±]4/Y[±]5/Z[±]5G01 Linear interpolationV: N3/G01/X[±]5/Y[±]4/Z[±]5/F3H: N3/G01/X[±]4/Y[±]5/Z[±]5/F3G02 Circular interpolation clockwiseG03 Circular interpolation counterclockwise

Quadrants:

V: N3/^{GO2}/_{GO3}/X[±]5/Y[±]4/Z[±]5/F3H: N3/^{GO2}/_{GO3}/X[±]4/Y[±]5/Z[±]5/F3

N3/M99/J2/K2 (Partial circles)

G04 Dwell

N3/G04

G21 Empty block

N3/G21

G25 Sub-routine program call

N3/G25/L(F)3

G27 Jump instruction

N3/G27/L(F)3

G40 Tool radius compensation cancelled

N3/G40

G45 Add tool radius

N3/G45

G46 Subtract tool radius

N3/G46

G47 Add tool radius twice

N3/G47

G48 Subtract tool radius twice

N3/G48

G64 Feed motors without current
(switching function)

N3/G64

G65 Magnetic tape operation
(switching function)

N3/G65

G66 Activating RS 232 Interface

N3/G66

G72 Pocket milling cycleV: N3/G72/X[±]5/Y[±]4/Z[±]5/F3H: N3/G72/X[±]4/Y[±]5G74 Thread-cutting cycle
(left-hand)N3/G74/K3/Z[±]5/F3G81 Fixed boring cycleN3/G81/Z[±]5/F3G82 Fixed boring cycle with dwellN3/G82/Z[±]5/F3G83 Fixed boring cycle with chip
removalN3/G83/Z[±]5/F3

G 84 Thread-cutting cycle

N3/G84/K3/Z⁺5/F3

G 85 Fixed reaming cycle

N3/G85/Z⁺5/F3

G 89 Fixed reaming cycle with dwell

N3/G89/Z⁺5/F3

G 90 Absolute value programming

N3/G90

G 91 Incremental value programming

N3/G91

G 92 Offset of reference point

V: N3/G92/X⁺5/Y⁺4/Z⁺5

H: N3/G92/X⁺4/Y⁺5/Z⁺5

V = Vertical

H = Horizontal

Miscellaneous or Switching Functions

M00 - Dwell
N3/M00

M03 - Milling spindle ON, clockwise
N3/M03

M05 - Milling spindle OFF
N3/M05

M06 - Tool offset, milling cutter radius input
N3/M06/D5/S4/Z ± 5/T3

M17 - Return to main program
N3/M17

M08	}	Switching exits N3/M2
M09		
M20		
M21		
M22		
M23		

M26 - Switching exit - impulse
N3/M26/H3

M30 - Program end
N3/M30

M99 - Parameters circular interpolation
(in connection with G02/03)
N3/M99/J3/K3

Alarm Signs

- A00: Wrong G/M code
- A01: Wrong radius / M99
- A02: Wrong Z-value
- A03: Wrong F-value
- A04: Wrong Z-value
- A05: M30 code missing
- A06: M03 code missing
- A07: No significance
- A08: Tape end with cassette operation
SAVE
- A09: Program not found
- A10: Writing protection
- A11: Loading mistake
- A12: Checking mistake
- A13: Inch/mm switching with full pro-
gram memory
- A14: Wrong mill head position/path in-
crement with LOAD \perp /M or \dashv /M
- A15: Wrong Y-value
- A16: Value of milling cutter radius
missing
- A17: Wrong sub-routine
- A18: Path milling cutter compensation
smaller zero

**Possible Inputs
(Otherwise alarm signs)**

	Metric		Inch	
	Values	Unit (mm)	Values	Unit (inch)
X _V	0-19999	1/100 mm	0-7999	1/1000"
X _H	0-9999	1/100 mm	0-3999	1/1000"
Y _V	0-9999	1/100 mm	0-3999	1/1000"
Y _H	0-19999	1/100 mm	0-7999	1/1000"
Z _{VH}	0-19999	1/100 mm	0-7999	1/1000"
Radii	0-9999	1/100 mm	0-3999	1/1000"
D(X) milling cutter radius with MO6	0-9999	1/100 mm	0-3999	1/1000"
F	2-499	mm/min	2-199	1/10"/min
T(F) tool address MO6	0-499	1	0-199	1
L(F) jump instruc- tions		0-221		
H(F) exit signs M26		0-299		
J/K circular para- meter		0-90		

Adresses

N, G, X, Y, Z, F, D, J, K, L, M, T, S, H

Operation CNC

INP	Storing of word contents
DEL	Deleting of word contents
FWD	Forward in program block by block
REV	Backward in program block by block
→	Forward in block word by word
M	Input of M-functions

Program hold:

INP + **FWD**

Program interruption

INP + **REV**

Delete program

DEL + **INP**

First **DEL** then **INP**

DEL remains pressed.

Delete alarm

INP + **REV**

Insert block

~ + **INP**

Delete block

~ + **DEL**

Single block mode

1 **2** **3** etc. + **START**

Testrun:

M

Operation – Magnetic tape

Storing of program on tape

G65 **INP** → **FWD** → Put in program
number → **INP**

Transmit program from tape to memory

G65 **INP** → **INP** → Select program
number → **INP**

Delete tape contents

G65 **INP**
↓
→ + **DEL**

Chapter 4

CNC-Basics

CNC-lathe – The control	4.1
CNC-machine – Main elements	4.2 – 4.3
What happens in CNC-manufacture	4.4 – 4.7
Differences in manufacture using a handoperated or a CNC-machine	4.8 – 4.9
This you are going to learn	4.11
What is programming	4.13 – 4.15
The coding standards	4.17 – 4.19
Program structure	4.21 – 4.23
G00/G01	4.25
Description of path lengths for slide movements	4.27
The CNC-program (structure)	4.29
The address words of the program sheet F1-CNC	4.31 – 4.33
Standardization of axis systems for CNC-machines	4.35 – 4.41
Concept of programming – Methods of programming	4.43
Dimensions of drawings	4.45
The modes of programming	4.47
G90/G91	4.49 – 4.51

Determining the coordinates for programming in absolute mode	4.53 – 4.55d
Information to the control concerning the workpiece zero-point	4.57
Fixing the origin of the coordinates on the F1-CNC (workpiece zero-point)	4.59
Fixing the zero-point of coordinates with G92 – Programmed offset of reference point	4.61 – 4.69
Various workpiece zero-points in one program	4.71 – 4.73
Mixed programming	4.75 – 4.77
Connection: G92 – Zero-point offset/ M06 – Tool lengths compensation	4.79
Some tips for procedure	4.81 – 4.83
The M-functions	4.85 – 4.87
Description of block formats	4.89
Types of controls of CNC machine tools	4.91 – 4.97
Programming – Geometry	4.99 – 4.143

CNC-Lathe The Control

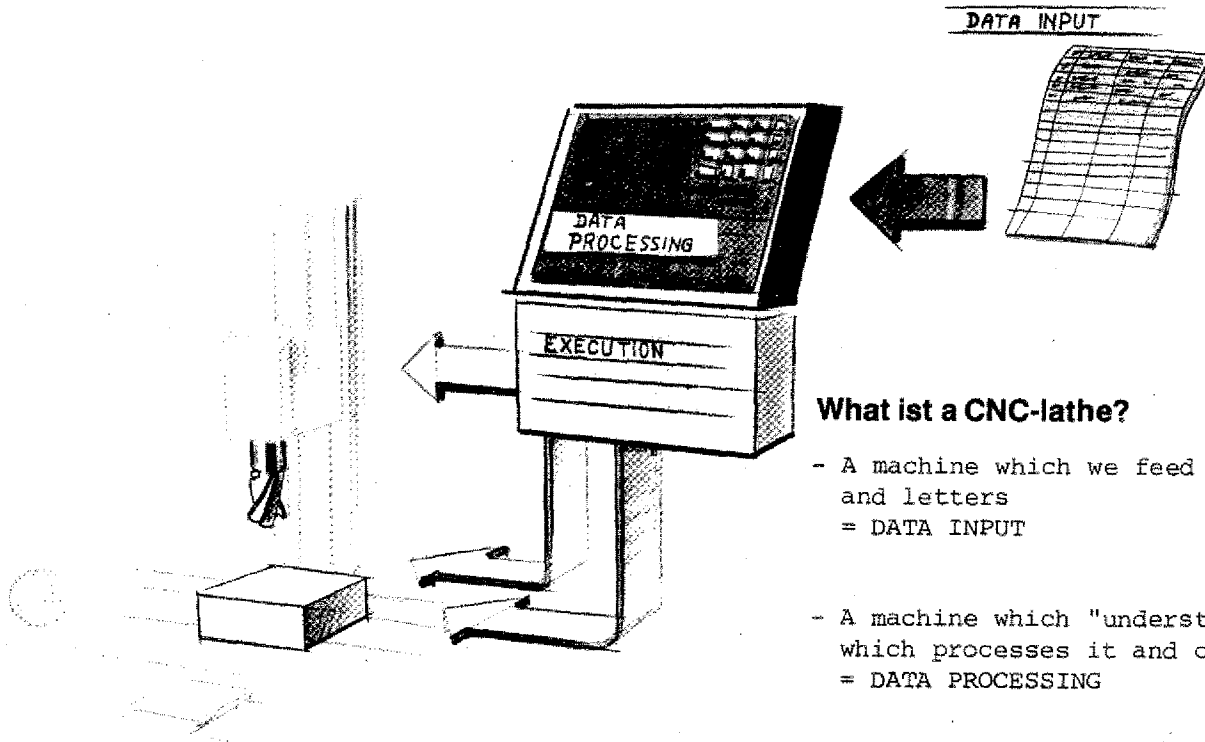

What is a CNC-lathe?

- A machine which we feed with figures and letters
= DATA INPUT
- A machine which "understands" the data which processes it and calculates.
= DATA PROCESSING
- A machine which passes on this calculated data in form of instructions.
= EXECUTION
- A machine which follows the instruction

Meanings in daily use

The meanings change quite often in their daily use. NC-machines were originally machines with numerical control, but no microprocessor. Today such machines are obsolete. The program was read in directly from the perforated tape.

Today NC-machines comprise all types CNC, DNC or AC types.

CNC — Machine — Main Elements — A "humanized" Comparson

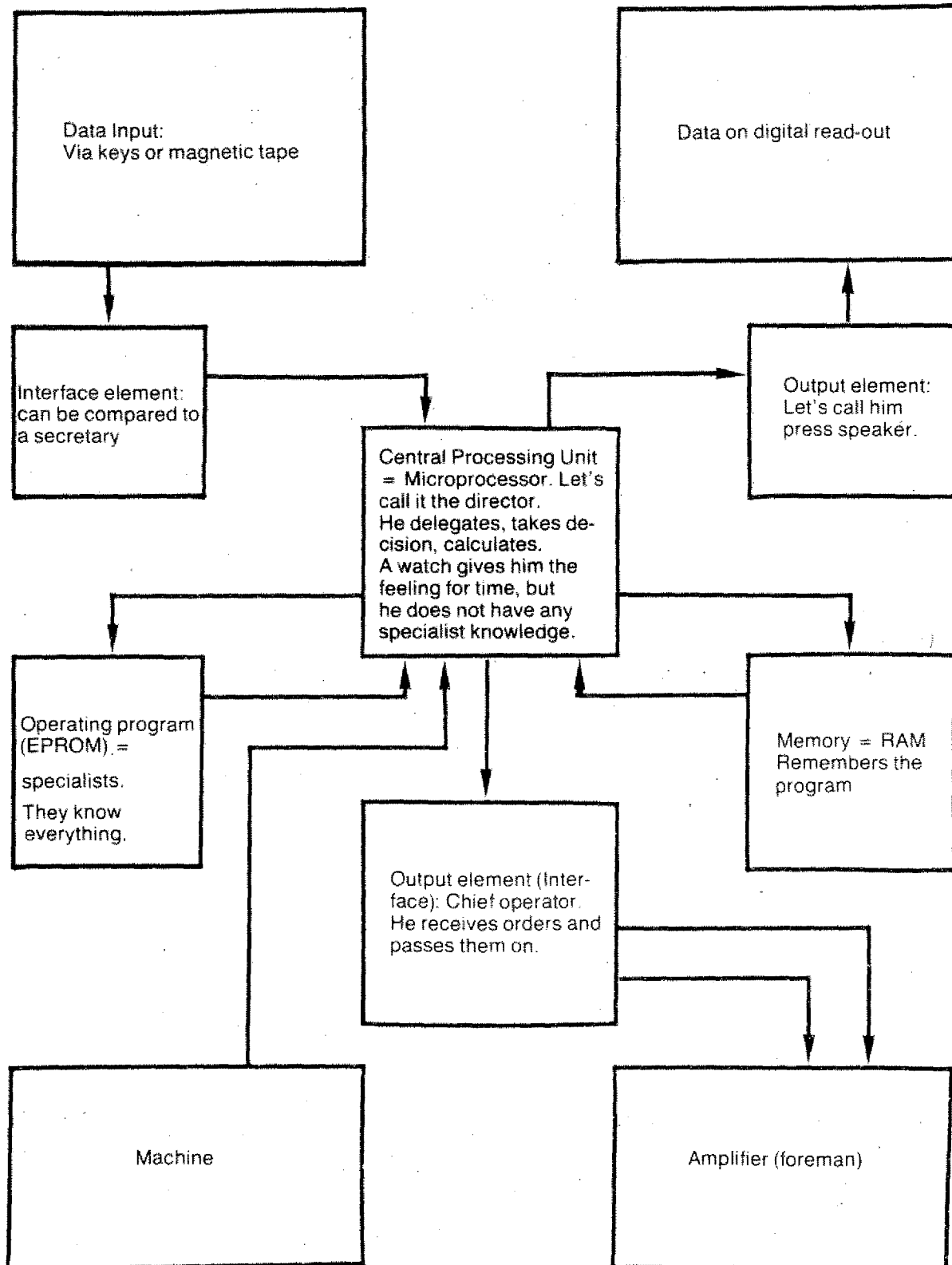

CNC-Machine – Main Elements

Data Input

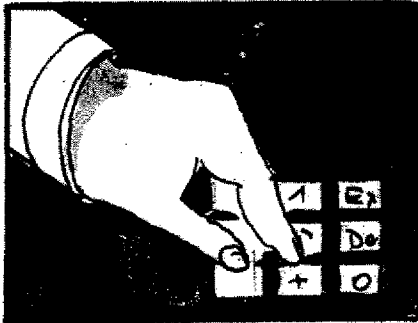

Digital read-out

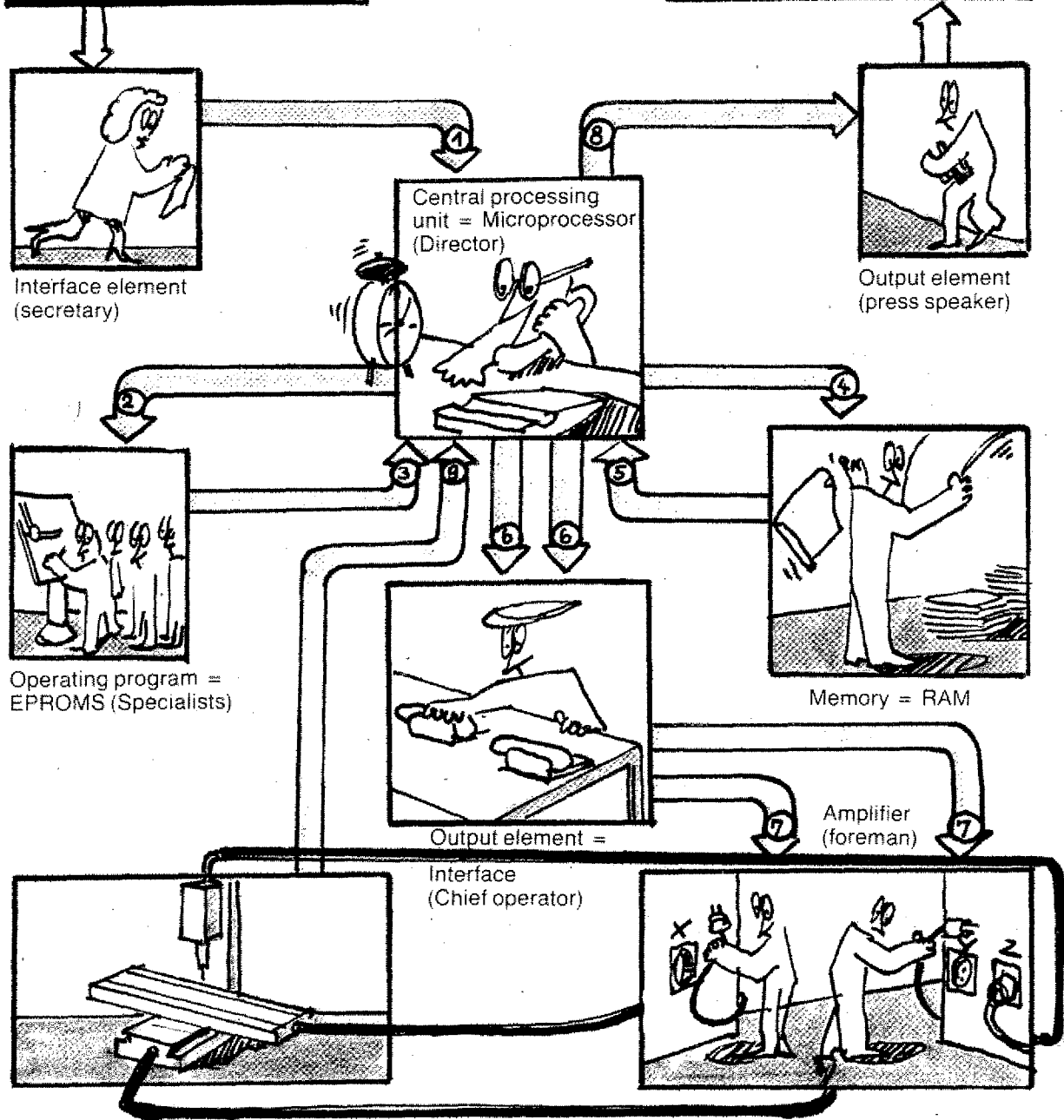
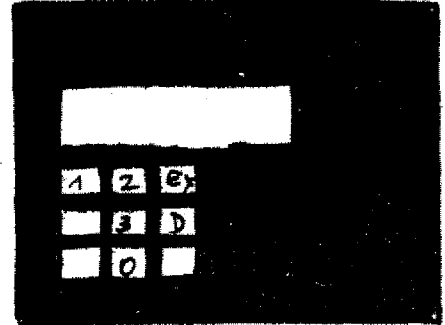

What happens in CNC-Manufacture

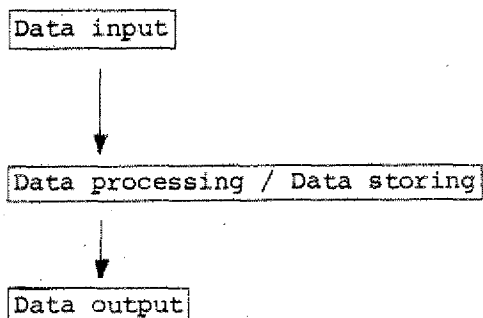

In the computer nothing happens without the director. There is a strict hierarchy.

What happens if you press the key START?

1. Secretary —→ Director:

"They pressed START!"

Director asks memory:

"Did they put in program end M30?"

If yes, the program can start.

2. Director —→ Specialists:

We want to machine a groove in a certain angle.

3. Specialist —→ Director:

"Yes, o.k."

4. Director —→ Memory:

"Please give me the data!"

5. Memory —→ Director:

X,Y slides have to be moved in ratio
1 : 4.

6. Director calculates and gives data to chief operator. With the aid of the watch he also determines the operating speed (when threading he waits for the main spindle position).

7. Chief operator —→ Foreman:

Move X slide with feed size F1 and Y slide with feed size F2.

8. Director —→ Press speaker:

"The block is finished. We work on the next. Let them know!"

What happens in CNC-Manufacture?

Data Input

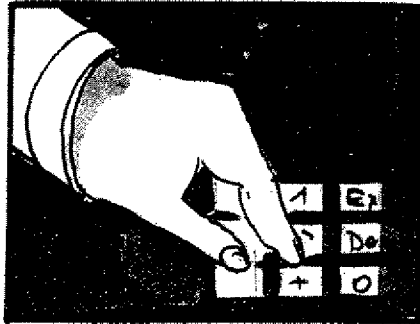

Digital read-out

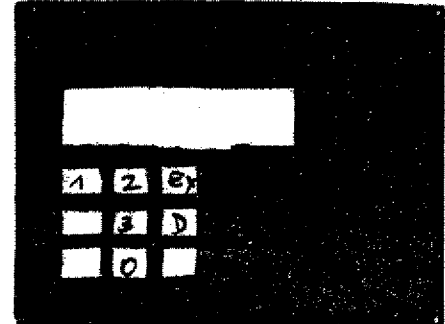

Interface element (secretary)



Output element (press speaker)

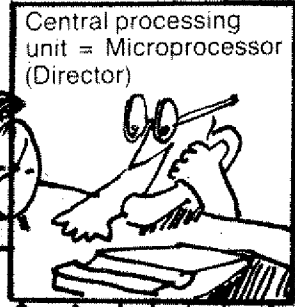

Central processing unit = Microprocessor (Director)

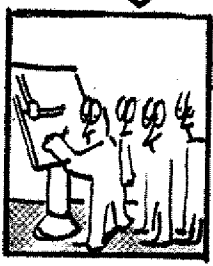

Operating program = EPROMs (Specialists)

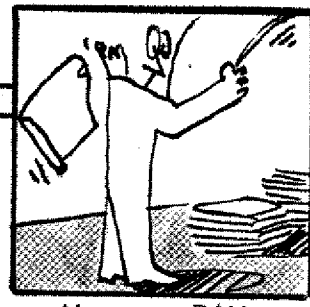

Memory = RAM

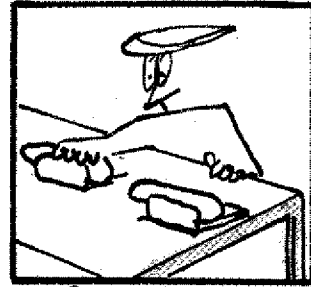

Output element =

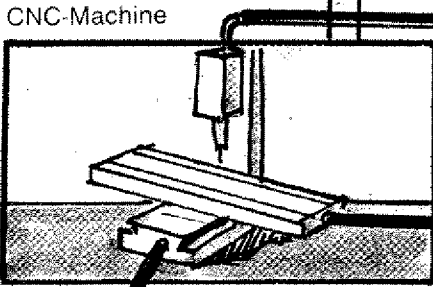

CNC-Machine

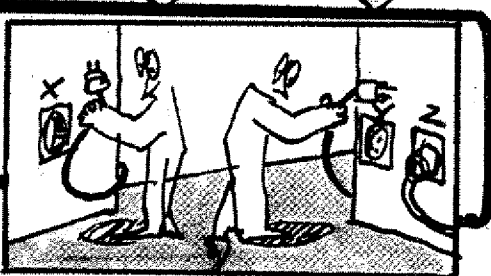

Amplifier (foreman)

Interface (Chief operator)

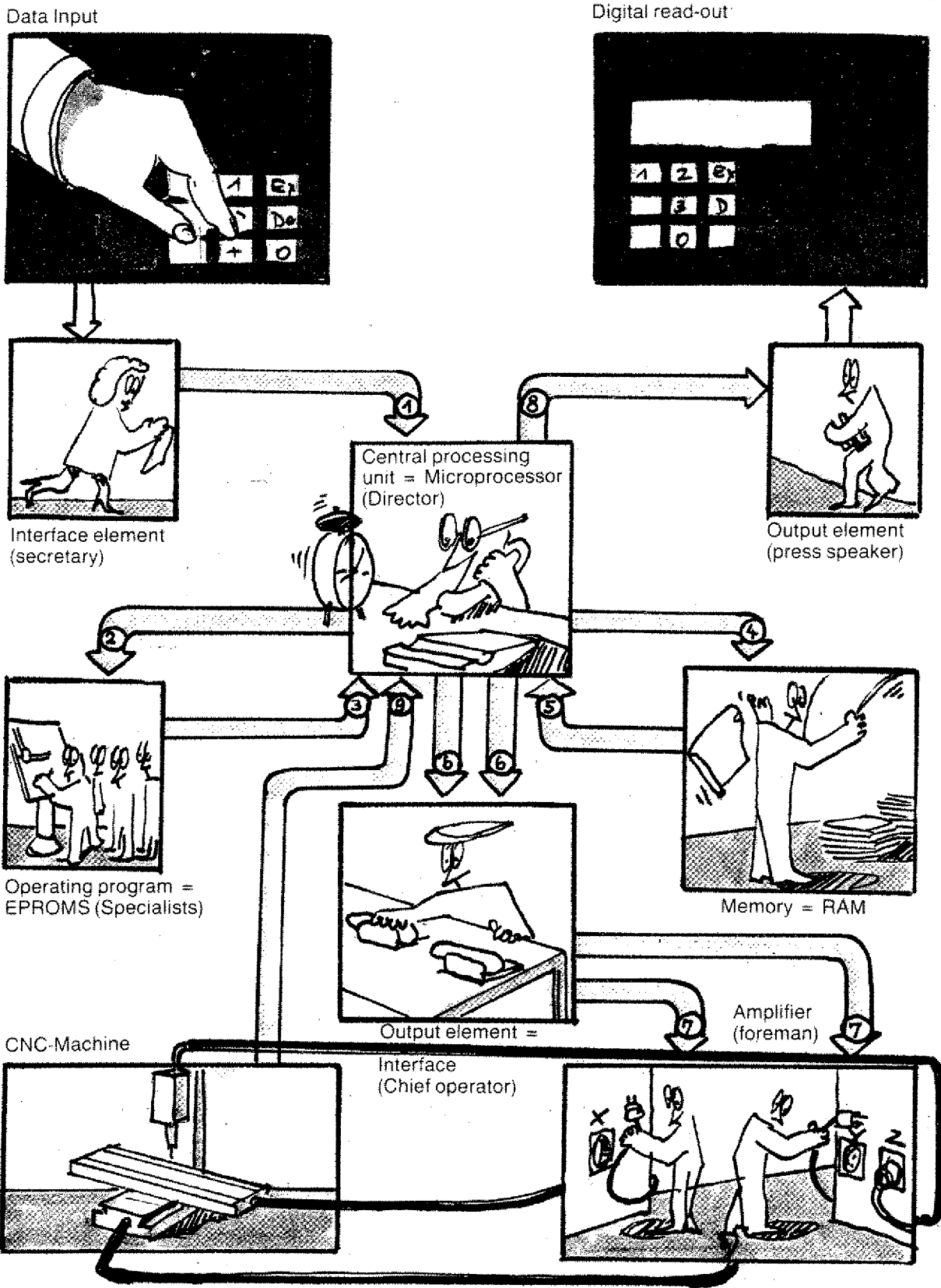

What happens in CNC-Manufacture

What knowledge is necessary in order to manufacture, using a hand operated or a CNC lathe?

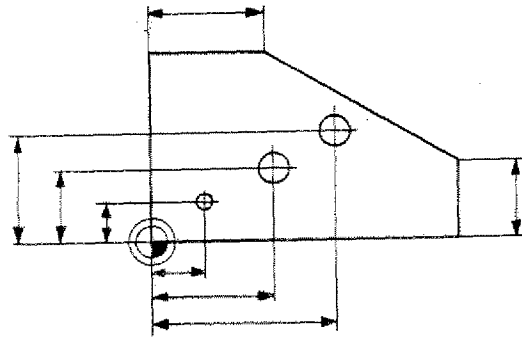

Hand operated machine

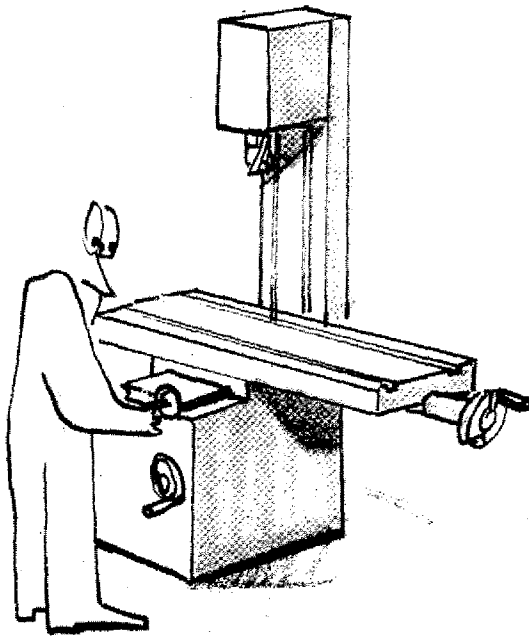

NC-machine

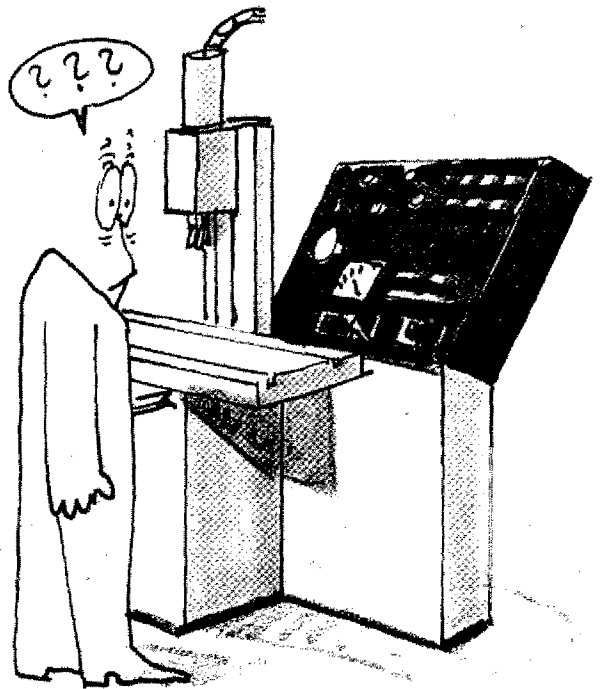

Differences in Manufacture using a hand operated or a CNC-Machine (Survey)

Hand operated machine

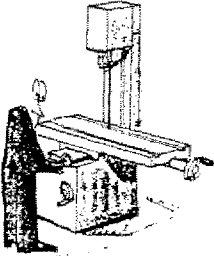

✓

CNC-Machine

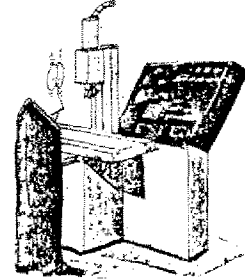

Necessary information

Technical drawing

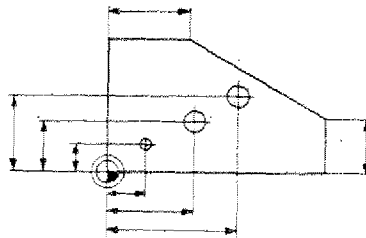

Necessary means

✓	Lathe	✓
✓	Chucking devices	✓
✓	Tools	✓

Necessary knowledge/Capabilities

(to execute operation)

✓	Reading of technical drawings	✓
✓	Knowledge about tool geometry	✓

Differences in manufacture, using a hand operated or a CNC-machine – continued

<u>Hand operated machine</u>		<u>NC-machine</u>
	Technological information	
	+ Cutting speed depending on - material of workpiece - tool (HSS, carbide tipped) - type of operation	
	+ Feed rate	
	+ Cutting depth	
	+ Performance and dimensions of machine	

Execution

Operator must know how to control the machine

+ Writing the NC-program

#	d	f	v	a	z	F	Remarks

+ Input of NC-program

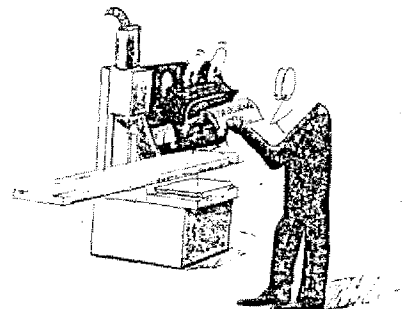

+ Preparing the machine

+ Execution

This you are going to learn

A rough survey

Set up a CNC-program

Enter all informations into program sheet.

Rules how to write these data have to be learned.



Put in program

You have to put in the information into the control. The control stores the information. You have to follow certain rules.



Give instruction to manufacture

The control works with the information entered - it calculates and gives instructions to the machine tool.



Check result

Correct program

Improve (optimize) program.

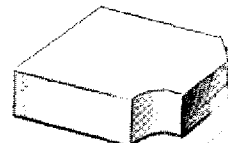
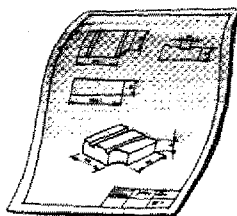
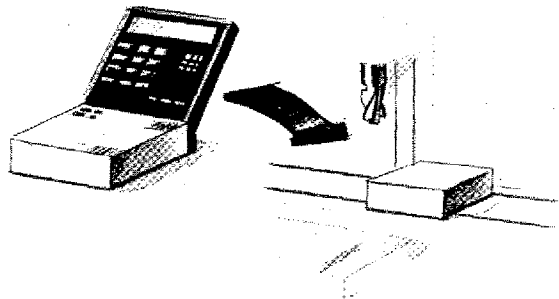
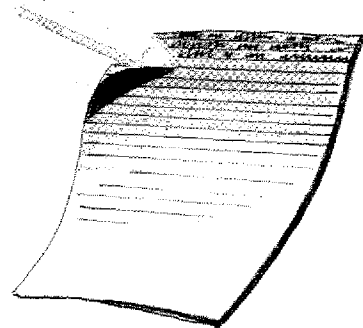

What is Programming?

Programming means to feed the computer with such data which it understands.

In other words, we have to "spoon-feed" the computer, list the data in orderly sequence and in a language which is familiar to the computer, which it understands, so that it can process the information.

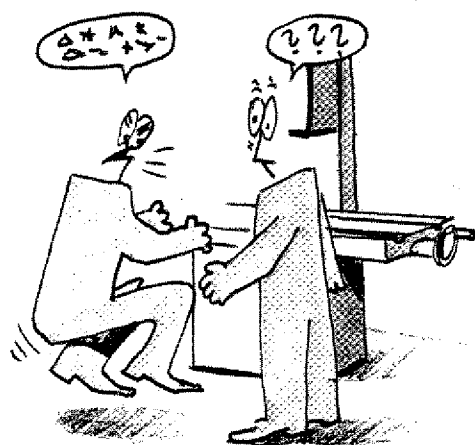

The operator does not understand the Chinese commands, because he does not speak this language.

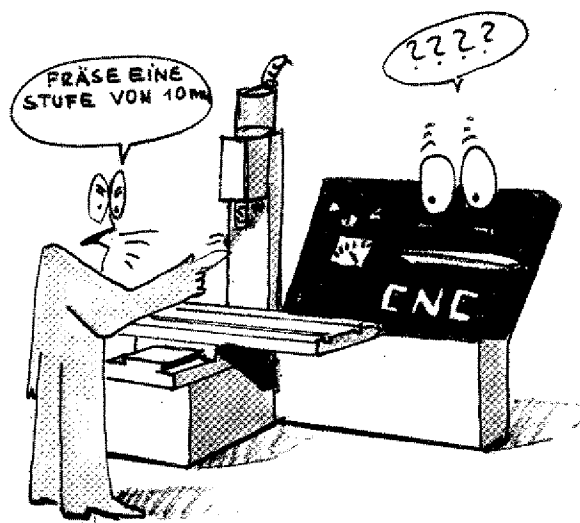

The CNC-machine does not understand the human language.

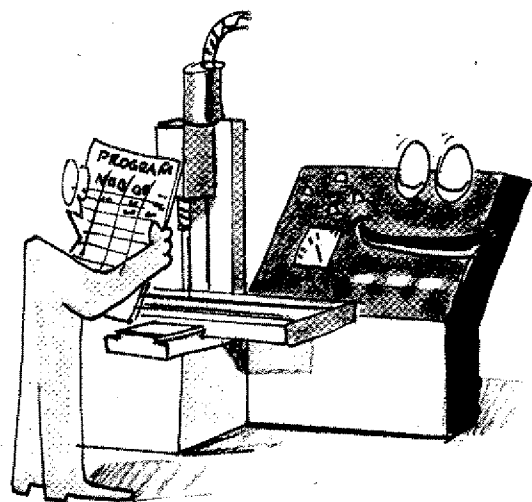

We have to feed the CNC-machine with data in a language it will understand. This language is "encoded".

Do you already know programming?

If you have operated a machine tool you automatically carried out the right movements.

Your brain gave instruction to your hands to operate the switches and levers in the correct sequence.

This job was automatized to a large extent.

When programming you have to write down all instructions.

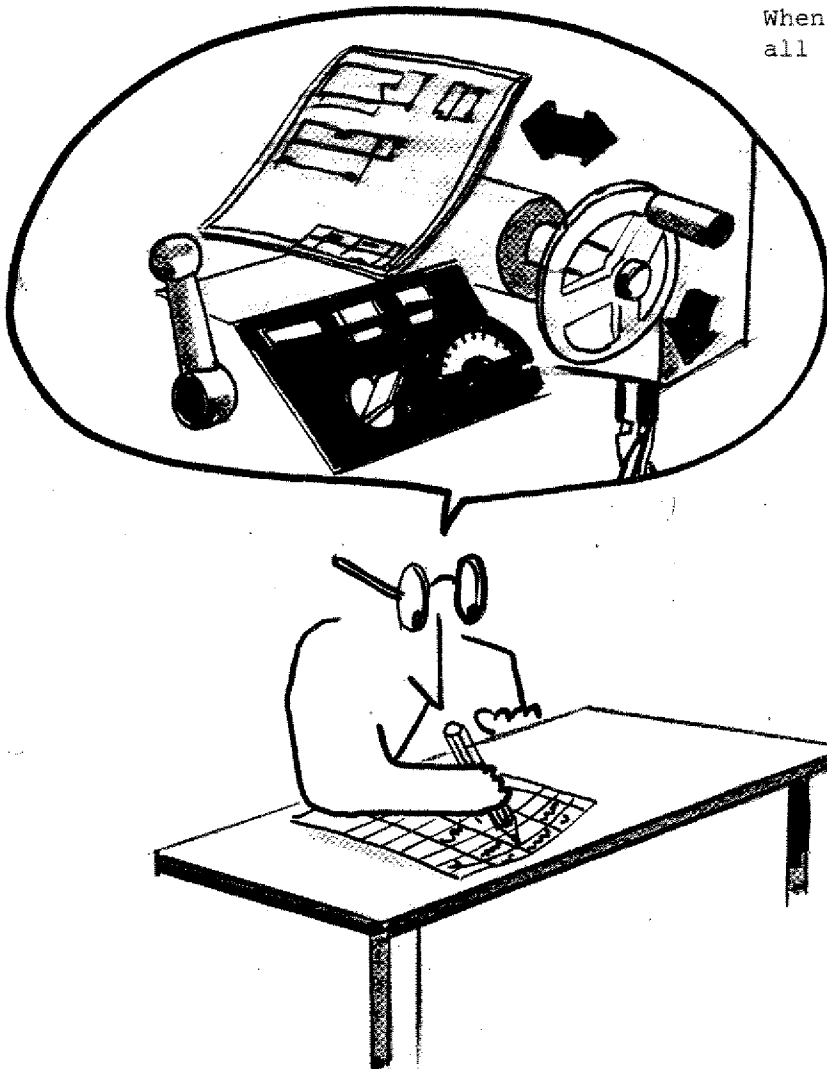

The instructions and informations must be

- in a systematic sequence
- complete
- and accurate.

They are given to the CNC-machine in a coded form.

The Coding Standards

The program structure for numerically controlled machine tools:

The program structure for numerically controlled machine tools:

How to code informations and instructions is defined by standards.

The standards are:

- Program structure for numerically controlled machine tools.
- According to DIN 66025 (German Industrial Standards)
- According to ISO 1056 (International Standard), new edition ISO 6983.

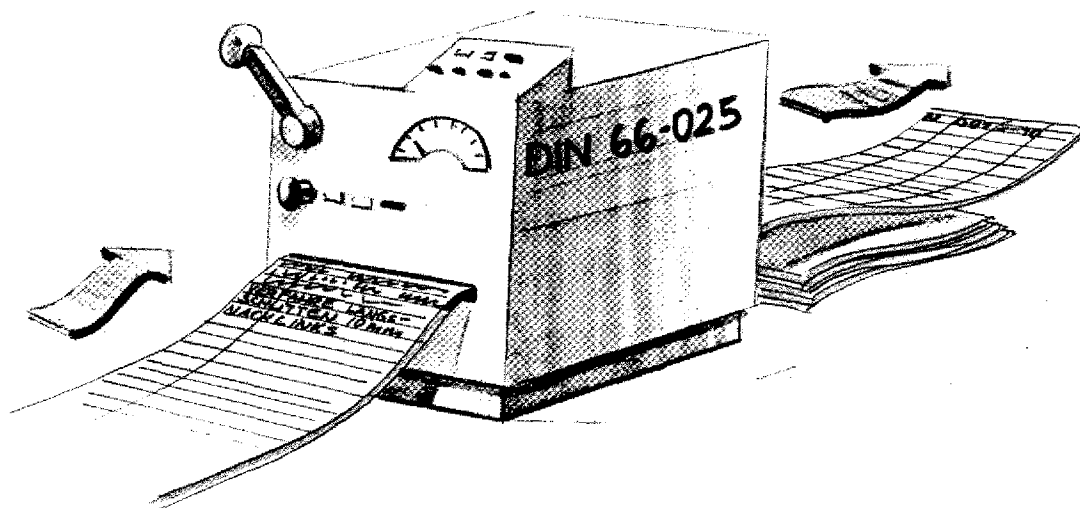

MOVE LONGITUDINAL SLIDE 10mm TO THE LEFT 200mm/min

=

N... / G01 / x+10 / F200

The coding rules must be learned by you so that you can write the program for the manufacture.

The Coding of Informations and Instructions (Criteria)

One could build a computer which understands instructions in normal language.

This would bring about quite some disadvantages:

<u>Language information</u>	<u>Criteria</u>	<u>Demands for coding</u>
Move the longitudinal slide - main spindle being switched on - with a given feed a distance of 25 mm at an angle of 37°.	1 It would be necessary to build a computer for each language (or even for each slang)	- Language neutral
	2 The long instructions are complicated and vague.	- Simple coding - Clear expression
	3 The language is practice oriented. This should also be true for CNC-instructions.	- Practice-oriented
	4 The code should be applicable to many different machine types.	- Universally applicable

When setting up standards for the program structure of CNC-machines the aim of the many experts was to create codes for instruction which should be

- as short as possible
- simple
- language neutral
- practice-oriented
- applicable to all machines.

Program Structure

Coding of the movements
Introduction of the Cartesian Coordinates
System.

Write down the instruction which you
would have to give for milling. The
milling spindle is on.

Number the instructions consecutively.

VERTICAL SLIDE

LONGITUDINAL SLIDE

CROSS SLIDE

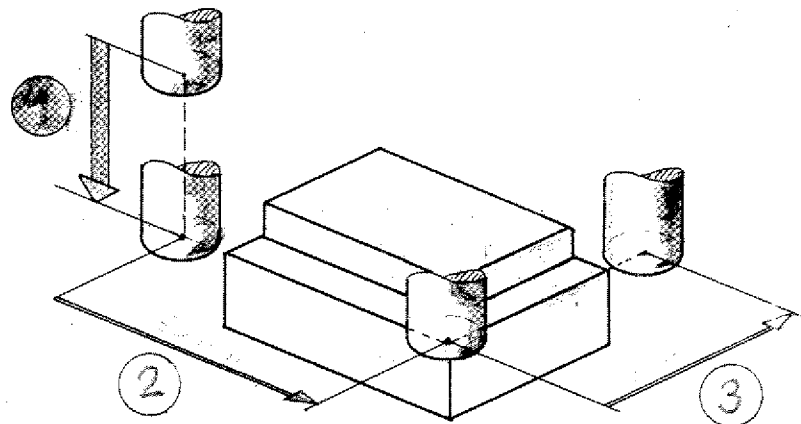
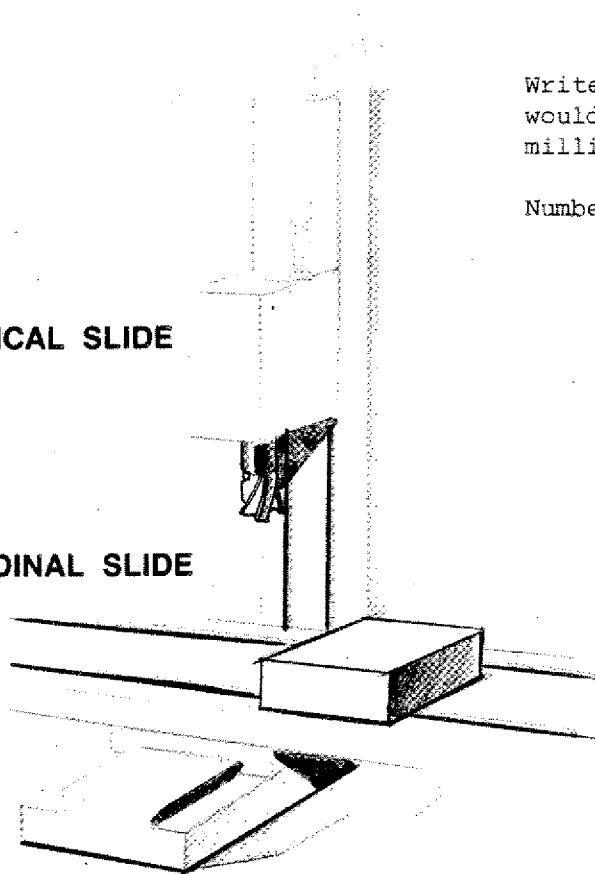

Coding of slide movements

The Instructions

- ① Move the vertical slide downwards (15 mm)
- ② Move the longitudinal slide to the left (50 mm)
- ③ Move the cross slide forward (30 mm)

are neither short nor language-neutral nor simple.

The movements are described using the axis denomination of the Cartesian Coordinates System.

For vertical mills

X-movement: longitudinal slide
Y-movement: cross slide
Z-movement: vertically

Instruction on direction

is achieved using \pm sign.

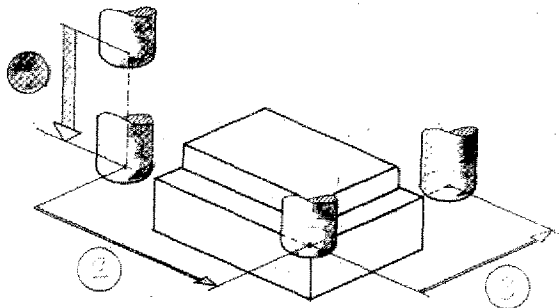
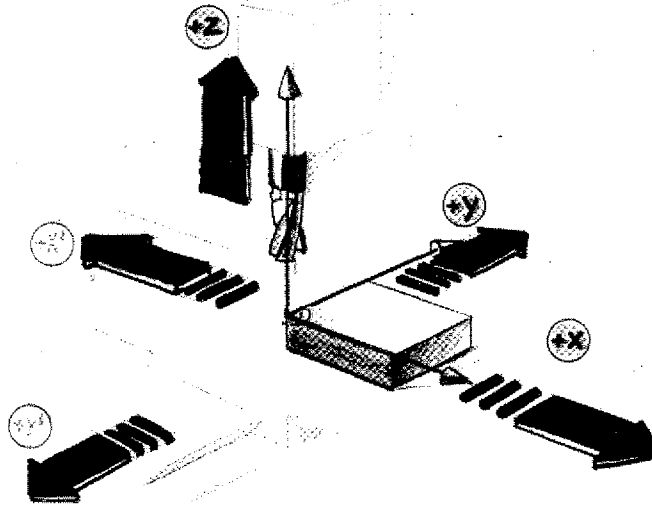

Coded instructions

- | | | |
|---|----|-------|
| ① | -Z | 15 mm |
| ② | +X | 50 mm |
| ③ | -Y | 30 mm |

The movement 1 is different to movements 2 and 3.

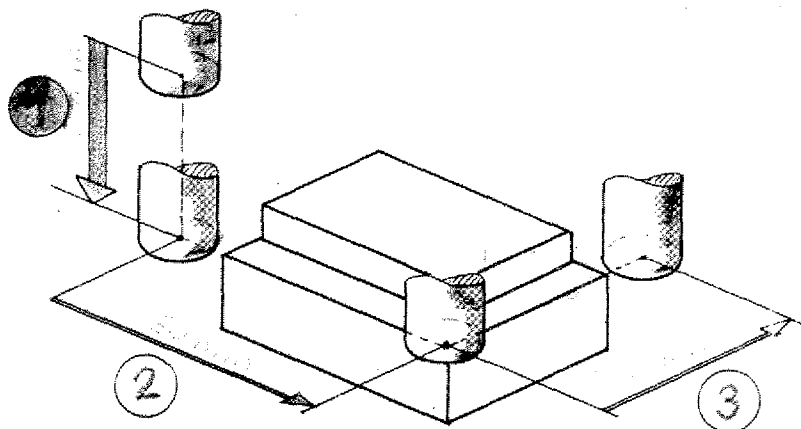

Movement 1

No chip removal

Speed as large as possible.

Coding:

Rapid traverse = G00

Movements 2 and 3

Straight movement and chip removal

Feed rate has to be set (depending on cutter dia., raw material, depth of cut etc.).

Coding

Linear interpolation = G01

N	G (M)	X (J) (D)	Y (K) (S)	Z	F (L) (T) (H)
...	00	0	0	-1500	
...	01	5000	0		
...	01	0	3000	0	

Description of Path Lengths for Slide Movements

Also in this case simple arrangements are made. The statement 'mm' (Milli-meter) is left out. Only the number is written.

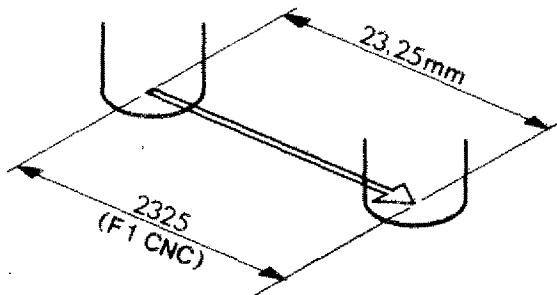

X -45,325 means: traverse -45,325 mm in X-direction.

On the F1-CNC path lengths are programmed without decimal point in 1/100 mm or 1/1000 inch.

Thus, 23,25 mm is programmed 2325 and 1,253 inch is programmed 1253.

Sign

Measures without signs are automatically "+" measures.

The Program Sheet

All informations and instructions are entered into the program sheet. Further explanations on the following page.

N	G (M)	X (J) (D)	Y (K) (S)	Z	F (L) (T) (H)	remarks

The CNC-Program (structure)

The program is written down in the program manuscript.

N	G (M)	X (J) (D)	Y (K) (S)	Z	F (L) (T) (H)
00	00	-3000	0	0	
01	01	0	-2500	0	120
02	01	1050	0		120
03	01	0	-1680	100	120
04	03	2000	2000		120
05	00	0	550	1500	

The program manuscript

All essential data for the manufacture of a workpiece are filled in. The composition of this program is called programming. The structure of such a program is standardized.

Parts of a program

N	G (M)	X (J) (D)	Y (K) (S)	Z	F (L) (T) (H)
00	00	-3000	0	0	
01	01	0	-2500	0	120
02	01	1050	0	0	120
03	01	0	-1680	100	120

1. The block

The program consists of blocks. A block contains all data necessary to execute an operation (i.e. order: move longitudinal slide straight on 25 mm, speed 120 mm/min).

N	G (M)	X (J) (D)	Y (K) (S)	Z	F (L) (T) (H)
00	00	-3000	0	0	
01	01	0	-2500	0	120
02	01	1050	0	0	120

2. The words

Each block consists of various words. Each word consists of a letter and a combination of numbers, e.g. N01.

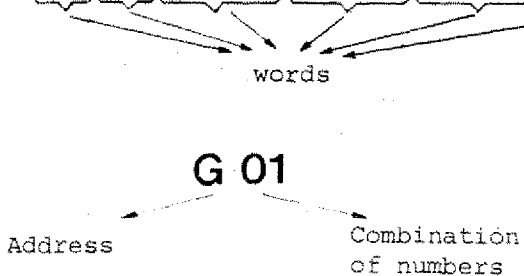

3. The word

A word consists of a letter and a combination of numbers. The letter is called address.

The Address Words of the Program Sheet/F1-CNC

N	G (M)	X (J) (D)	Y (K) (S)	Z	F (L) (T) (H)

1. The N-address:

N = abbreviation of number
 The instructions and informations are numbered. We talk about block number.
 On the F1-CNC: NOOO up to N221.

N	G (M)	X (J) (D)	Y (K) (S)	Z	F (L) (T) (H)

2. The G-address:

Into this column we enter the key information, i.e. the G-function or preparatory function. You will get to know the various G-functions in the course of our exercises.

N	G (M)	X (J) (D)	Y (K) (S)	Z	F (L) (T) (H)

3. The X,Y,Z-addresses:

They are the columns for the path data.
 F1-CNC:
 The paths are programmed without decimal point in 1/100 mm and/or 1/1000".

N	G (M)	X (J) (D)	Y (K) (S)	Z	F (L) (T) (H)

4. The F-address:

F stands for "feed". For each chip removal movement the appropriate feed has to be programmed.
 F1-CNC:
 The feed is programmed in mm/min or 1/10 inch/min.

N	G (M)	X (J) (D)	Y (K) (S)	Z	F (L) (T) (H)

5. The M-address:

M stands for "miscellaneous".
 M-functions are called "auxiliary functions". The M-values are entered into the G-column.

N	G (M)	X (J) (D)	Y (K) (S)	Z	F (L) (T) (H)

6. The D-address:

The cutter radius is described under D.
Radius 5 mm → D 500 (compare MO6 Tool compensation).

N	G (M)	X (J) (D)	Y (K) (S)	Z	F (L) (T) (H)

7. The S-address:

S stands for speed.
2000 rpm → S 2000 (compare MO6)

N	G (M)	X (J) (D)	Y (K) (S)	Z	F (L) (T) (H)

8. The T-address:

T stands for tool.
Tool number 2 → T02 (compare tool lengths compensation).

N	G (M)	X (J) (D)	Y (K) (S)	Z	F (L) (T) (H)

9. The J,K-addresses:

J,K are parameters for circle programming.
These addresses are described in chapter G02/G03.

N	G (M)	X (J) (D)	Y (K) (S)	Z	F (L) (T) (H)

10. The L-address:

is a jump address; compare G25, G27.

Standardization of Axis Systems for CNC-Machines

The axis systems are standardized for the various types of machinery according to ISO 841 and DIN 66217. The basis is the Cartesian Coordinates System (clockwise).

The right-hand rule can be of quite some help: it shows the position of the axes to one another.

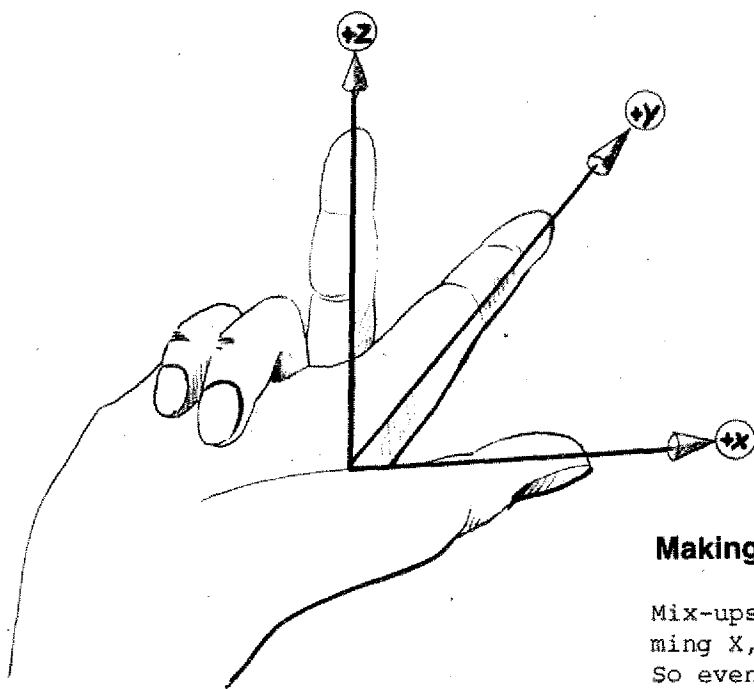

Making Programming Easier

Mix-ups are quite common when programming X,Y,Z and the +/- directions. So even quite experienced programmers use auxiliary devices. Use the model of the coordinates system and you will commit less mistakes.

Axis System Milling Machines

Milling machines and machining centers are of different construction typologie.

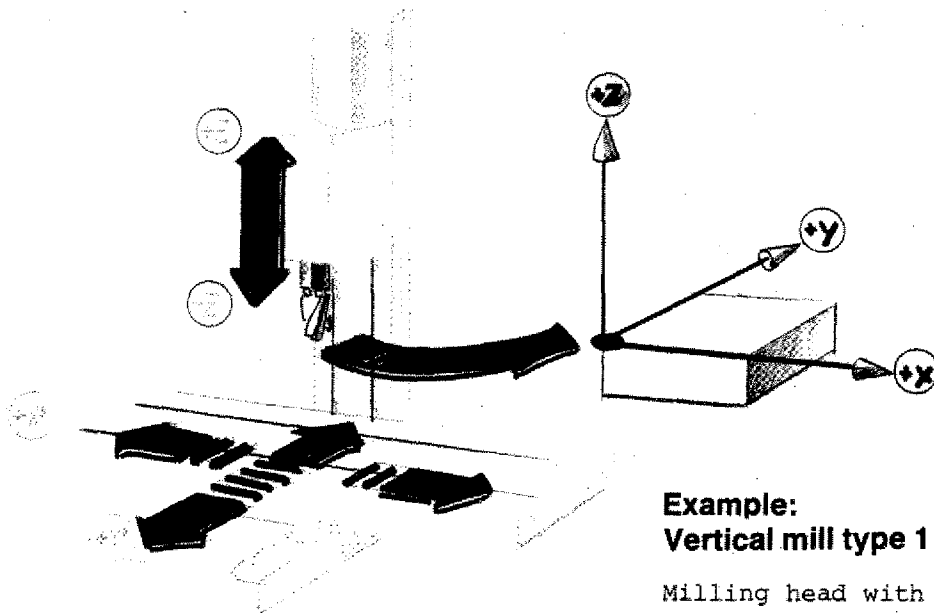

Example: Vertical mill type 1

Milling head with tool moves.

The mounted workpiece carries out longitudinal and cross movements.

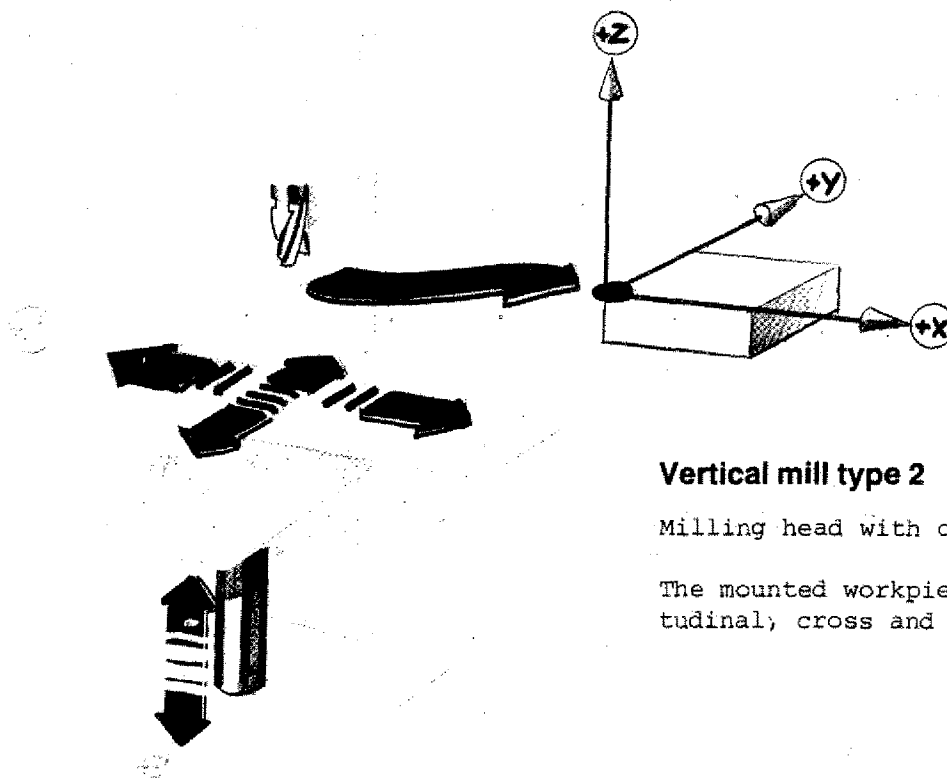

Vertical mill type 2

Milling head with cutter is fixed.

The mounted workpiece carries out longitudinal, cross and vertical movements.

Description of Cutter Path

If you would have to directly describe the slide movements, it would need a continuous rethinking with the various different machine construction types.

Example: Drilling a hole

Type 1: Move milling head downwards.

Type 2: Move vertical slide upwards.

A confusing situation.

Thus, the important simple statement for CNC-machines!

The path of the cutter is described.
For the programming it is all the same, whether the slides or the tool move during manufacture.

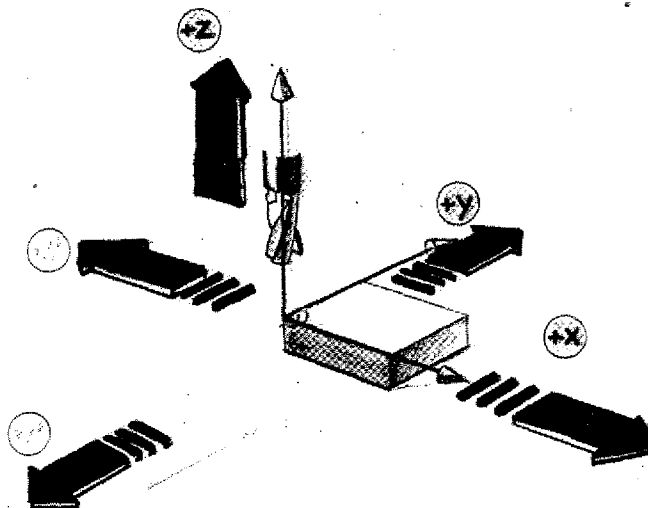

**Axis System
Vertical Mills**

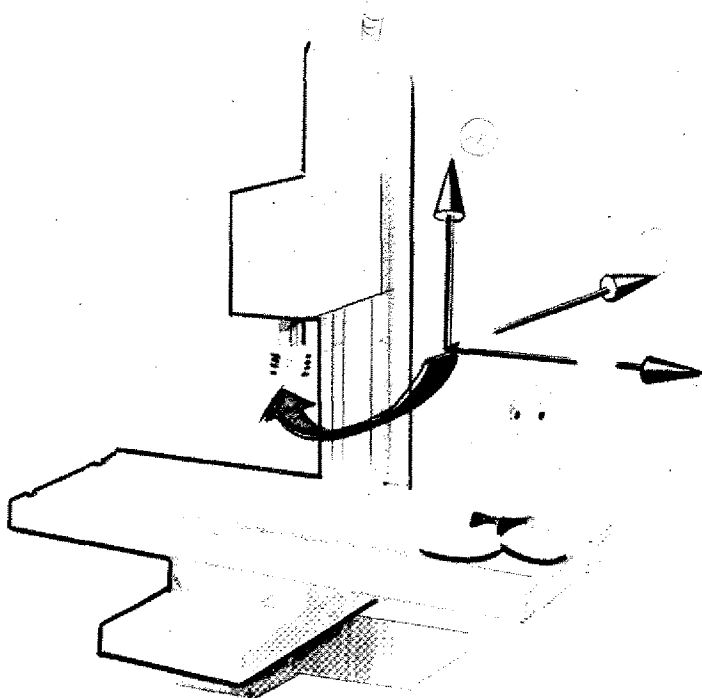

**Axis system
Horizontal mills**

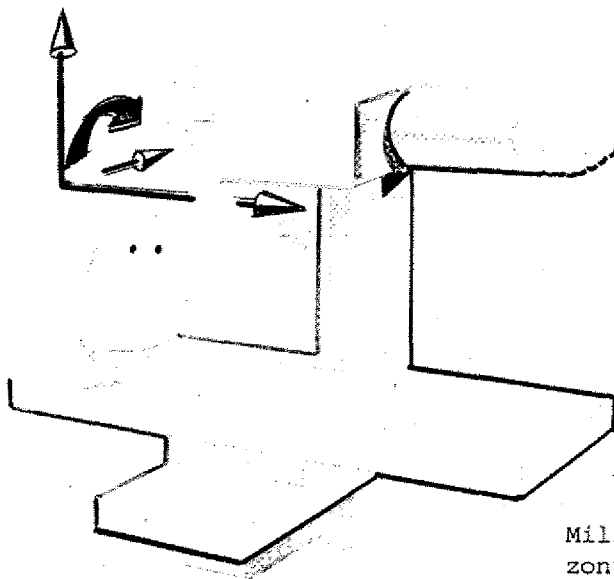

Milling programs on vertical or horizontal mills are different. The Z-axis is always the main spindle axis.

A minus Z-movement is always a feed-in movement into the workpiece (e.g. drilling).

Concept of Programming – Methods of Programming

Basically there are two methods to describe the path: absolute or incremental.

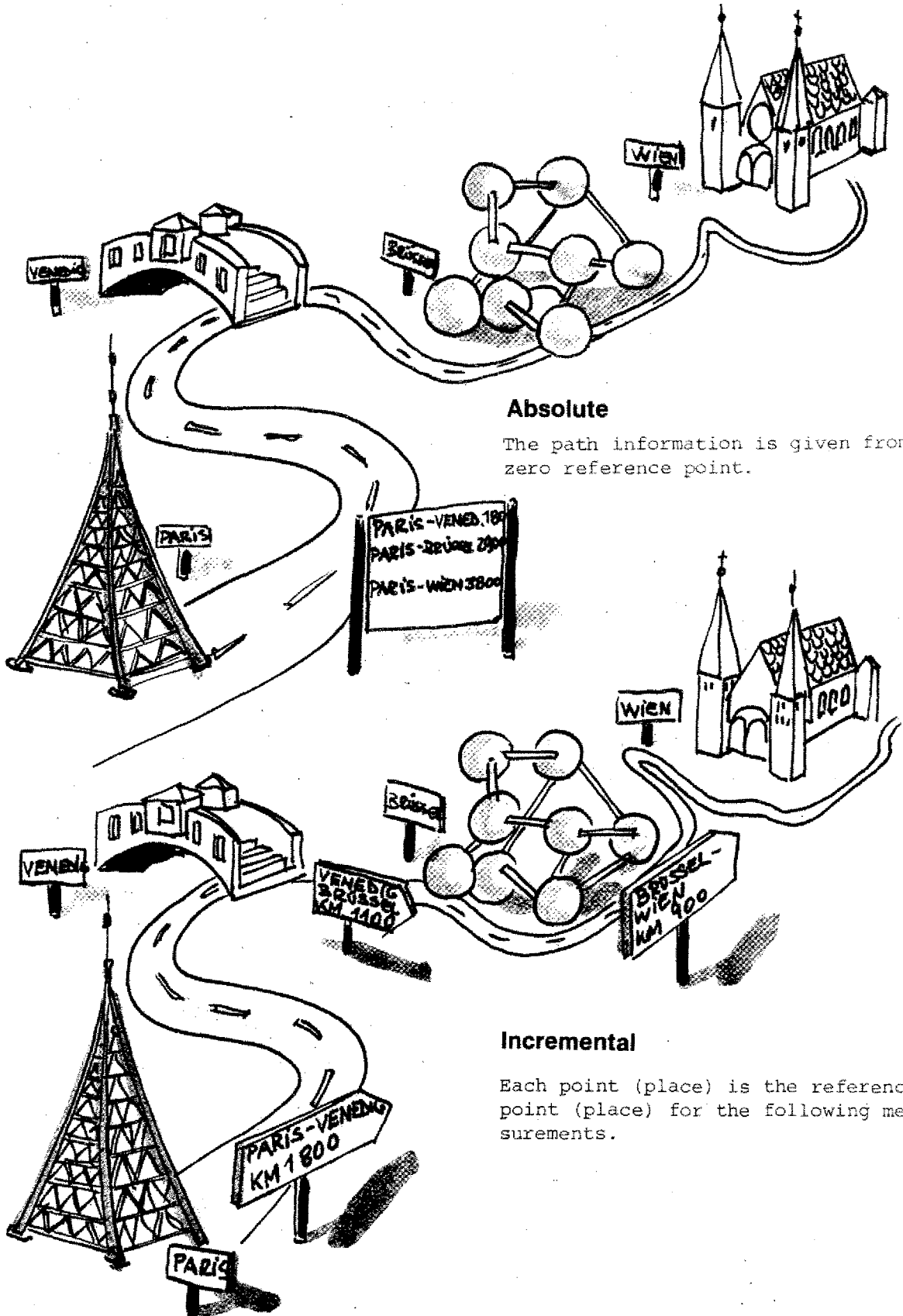

Absolute

The path information is given from a zero reference point.

Incremental

Each point (place) is the reference point (place) for the following measurements.

Dimensions of Drawings

There are different types of dimensioning in technical drawings.

Incremental dimensioning

Starting point for the dimensioning of the next point is always the actual point which was described last.

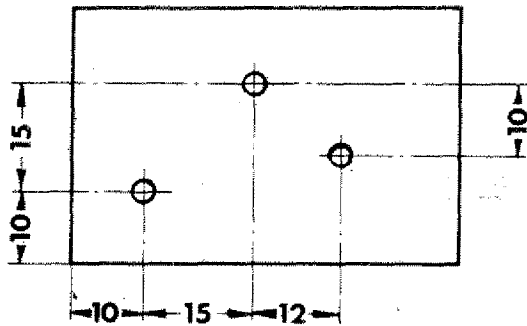

Absolute dimensioning

Zero-point for the dimensioning of all points is a remaining fixed point.

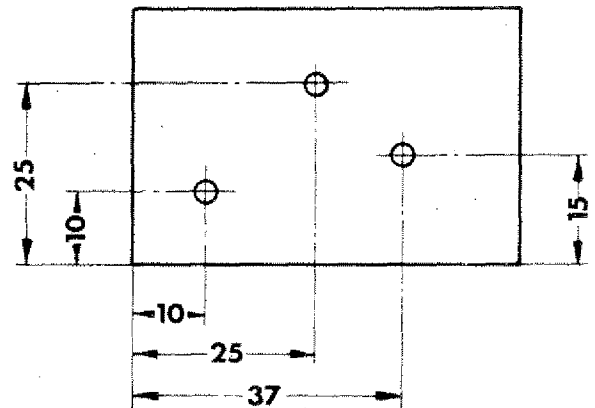

Mixed dimensioning

In most technical drawings you find both types of dimensioning. Some measures are given from one common point (absolute) or in the incremental mode (from the actual point described last).

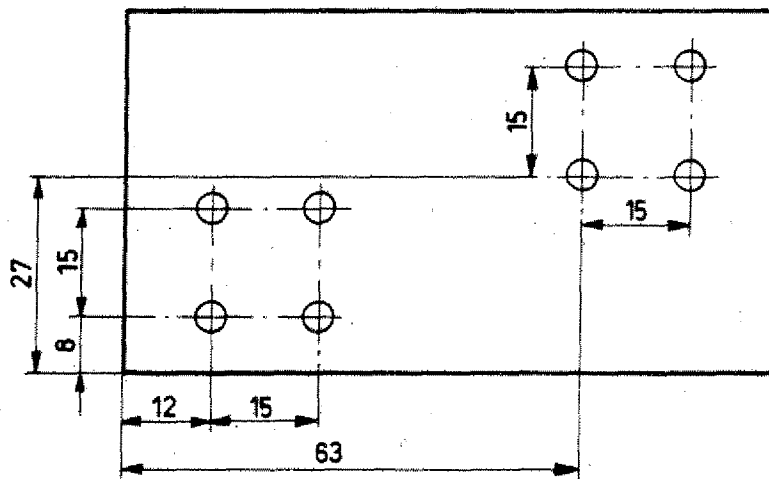

The Modes of Programming

It was the aim to achieve a very simple description of the traverse movements.

You can program the points and traverse movements in two different modes - so to avoid changing of dimensions in the drawing.

To instruct the computer how to calculate the values it is necessary to give a key information.

This is achieved by a G-instruction.

G90

- Absolute mode description
- Absolute mode programming (reference point programming)

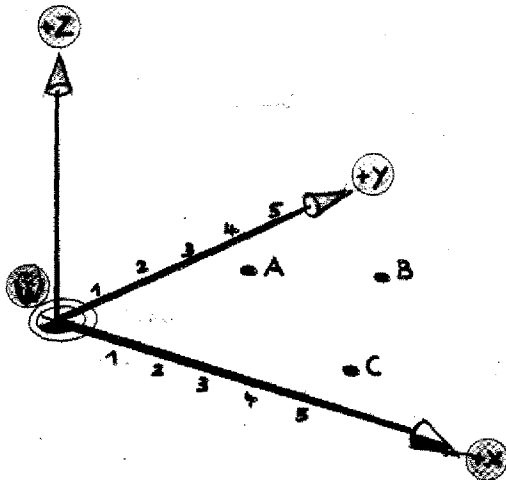

N	G (M)	X (J) (D)	Y (K) (S)	Z	F (L) (T) (H)

- You start from one point and describe all other points.
- The zero-point of the coordinates system can be defined by you.

G91

- Incremental mode description
- Incremental mode programming

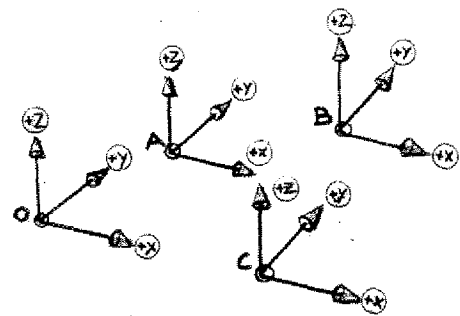

N	G (M)	X (J) (D)	Y (K) (S)	Z	F (L) (T) (H)

- You describe point 1 starting from point 0.
- You describe point 2 starting from point 1.
- You describe point 3 starting from point 2, etc.

You have to imagine the coordinates system shifted into the relative point.

When do you have to give the G90/G91 information to the computer? The initial status of a CNC-machine

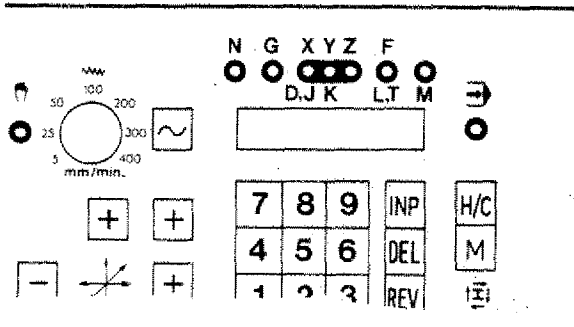

When you switch on the main switch the machine is in mode of operation "hand operation" = initial status.

If you press the **H/C** key, the mode of operation is switched to "CNC-operation".

The "initial status" of the control is incremental. All traverse movements are calculated in incremental mode.

G90 – Absolute value programming

G90 has to be programmed.

G91 – Incremental value programming

You may program G91, however it is not necessary since the control calculates incrementally by itself.

N	G (M)	X (J) (D)	Y (K) (S)	Z	F (L) (T) (H)	E
	G90					
	G91					

Handwritten annotations: A bracket groups the first four rows as "Absolute" and the last four rows as "Incremental".

N	G (M)	X (J) (D)	Y (K) (S)	Z	F (L) (T) (H)
	G91				
	G90				

Handwritten annotations: A bracket groups the first three rows as "Incremental" and the last three rows as "Absolute".

G90 is a self-maintaining modal function. It is valid until it is revoked, i.e. until G91 is programmed.

G91 is a self-maintaining modal function. G91 is revoked by G90.

Exercise

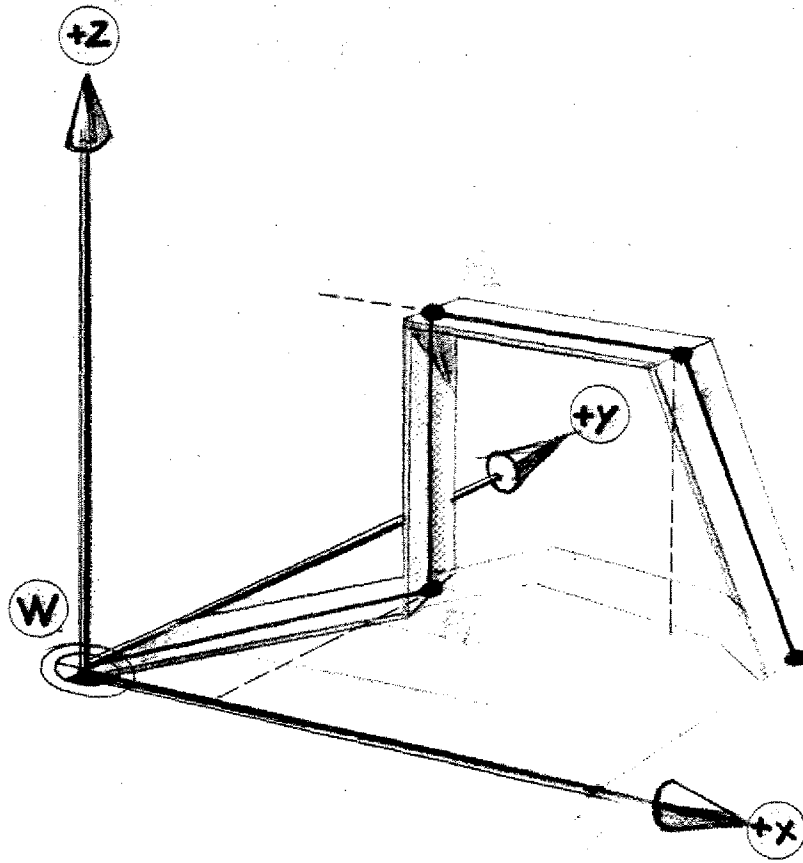

Exercise

Describe points P1, P2, P3, P4, P5 as absolute data.

Write in block NOOO the information for the mode of programming.

N	G (M)	X (J) (D)	Y (K) (S)	Z	F (L) (T)

Exercise

Describe points P1, P2, P3, P4, P5 as incremental data.

N	G (M)	X (J) (D)	Y (K) (S)	Z	F (L) (T)

Determining the Coordinates for Programming in Absolute Mode

Determining the workpiece zero-point in the technical drawing

In technical drawings the measures are often taken from one reference point.

For programming it is convenient that as many measures as possible can be taken over from the drawing - without calculation work.

You as programmer can determine the zero-point of the workpiece. The ideal choice can best be seen in the workpiece drawing.

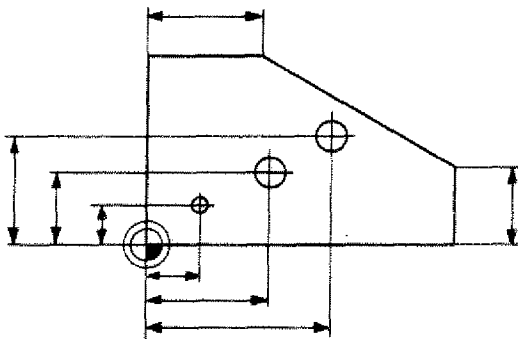

Symbol

W
Short
description

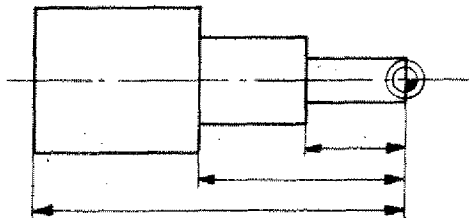

- Where to set the workpiece zero-point is your own decision.
- Pay attention to the signs of the axis.
- Write axis signs and \pm signs in the drawings not described.

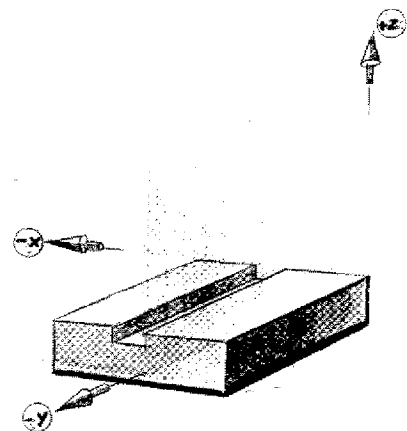
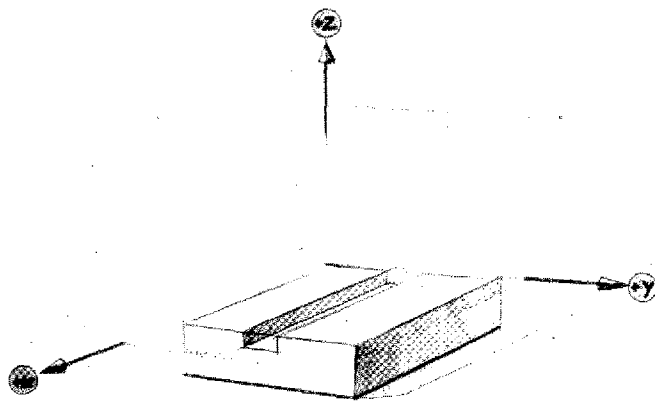
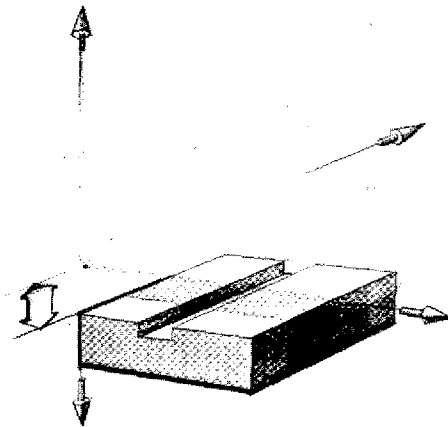
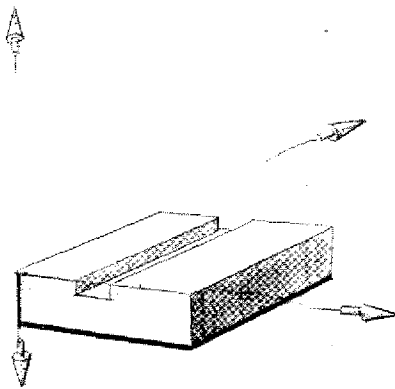

X – Y Plane in Center of Body

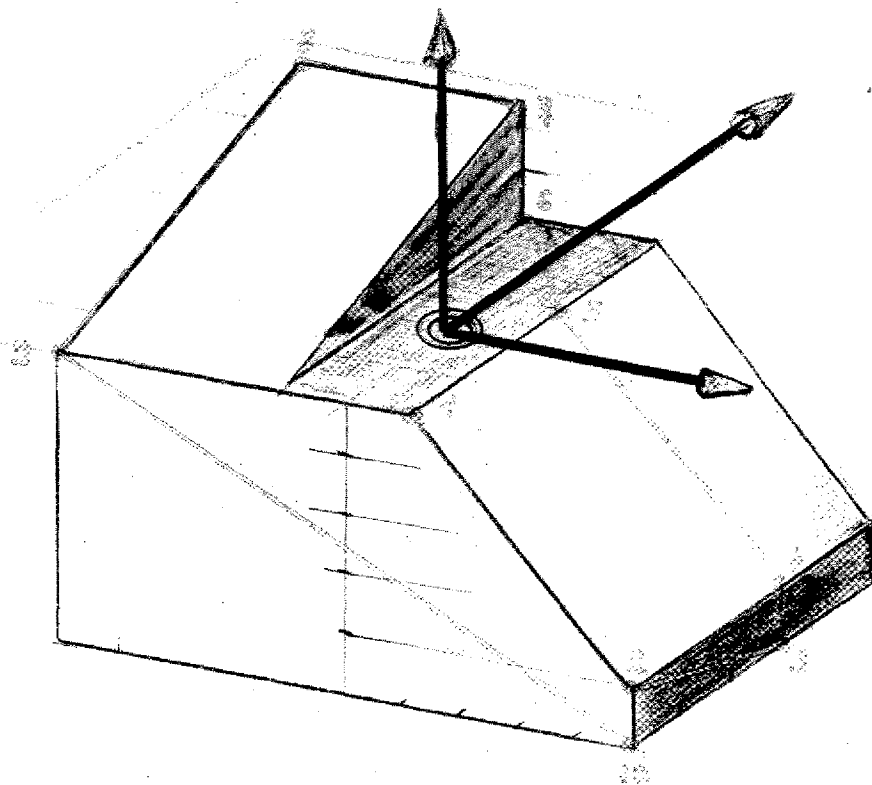

Absolute

N	G (M)	X (J) (D)	Y (K) (S)	Z	F (L) (T) (H)

Incremental

N	G (M)	X (J) (D)	Y (K) (S)	Z	F (L) (T) (H)

Informations to the Control concerning the Workpiece zero-point

You can instruct the control with G90/
.G91 how it should calculate the move-
ments - in absolute or incremental mode.

Absolute value programming

Where is the origin of the coordinates
system situated?

The control unit of a CNC-machine can
neither see nor think.

- It does not know the position of the
workpiece mounted to the slide.
- It cannot read the technical drawing
and thus cannot know the position of
the workpiece zero-point chosen by
you.

CNC-solution:

We have to instruct the control where
we want the origin of coordinates.

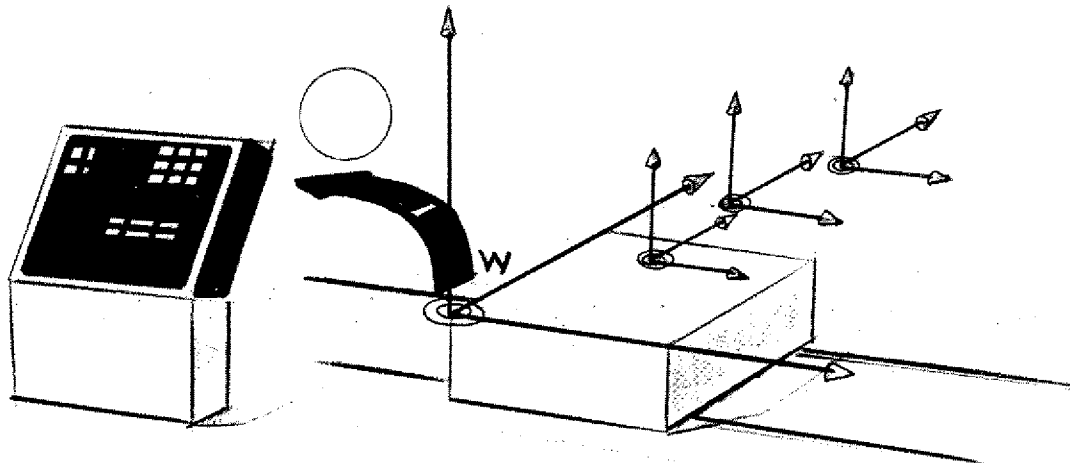

Fixing the Origin of the Coordinates on the F1-CNC (Workpiece zero-point)



Possibility 1:

Fixing with G90

If the computer receives a G90 instruction in the course of the program, it considers the actual slides position as zero-point.

In the left side mentioned situation you could not take any workpiece measures from the drawing. You would have to calculate.

This is only useful if you shift the origin of the coordinates system to the workpiece zero-point.

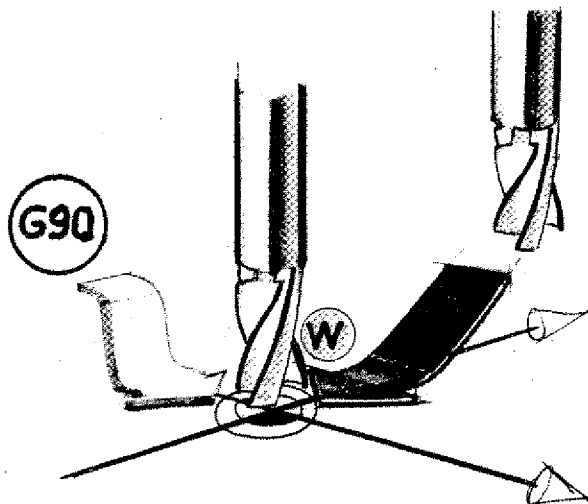
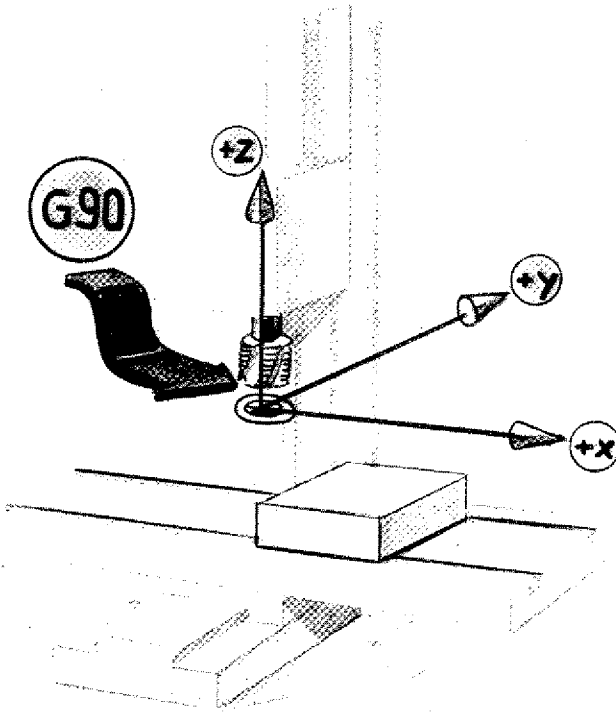

Example:

You move the cutter to the zero-point chosen by you. If the cutter is in this position you program G90. The origin of the coordinates is set.

Fixing the Zero-point of Coordinates with G92

G92 – Programmed offset of reference point

- We have set the workpiece zero-point.
- The cutter position is known to you (distance workpiece zero-point to cutter).

Information to computer with G92

You describe the cutter position looked at from the workpiece zero-point. In this way you fix the workpiece zero-point selected by you.

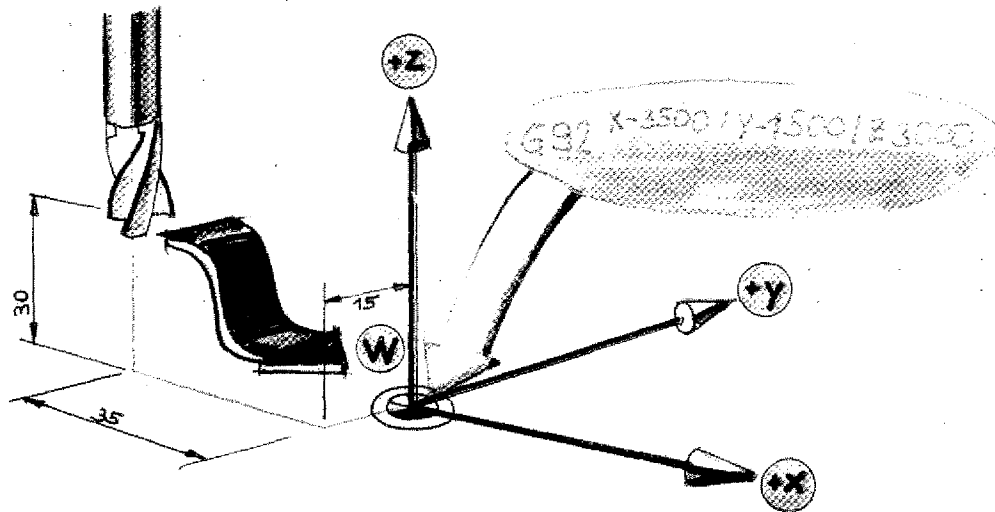



Format G92
N3/G92/X ± 5/Y ± 4/Z ± 5
(vertical)

N3/G92/X ± 4/X ± 5/Z ± 5
(horizontal)

Attention:

- G92 is an information, no instruction to traverse.
- G92 means automatically absolute value programming.
- The zero-point of the workpiece can be set off with G92 within a program as often as wanted.

Exercises

Program the workpiece zero-point

Program the tool to the workpiece zero-point.

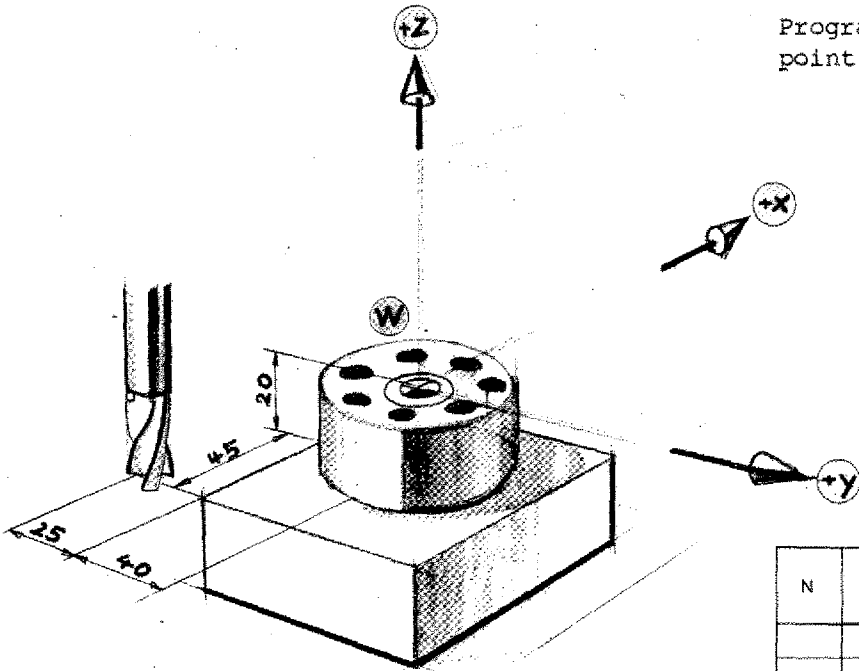

N	G (M)	X (J) (D)	Y (K) (S)	Z	F (L) (T) (H)

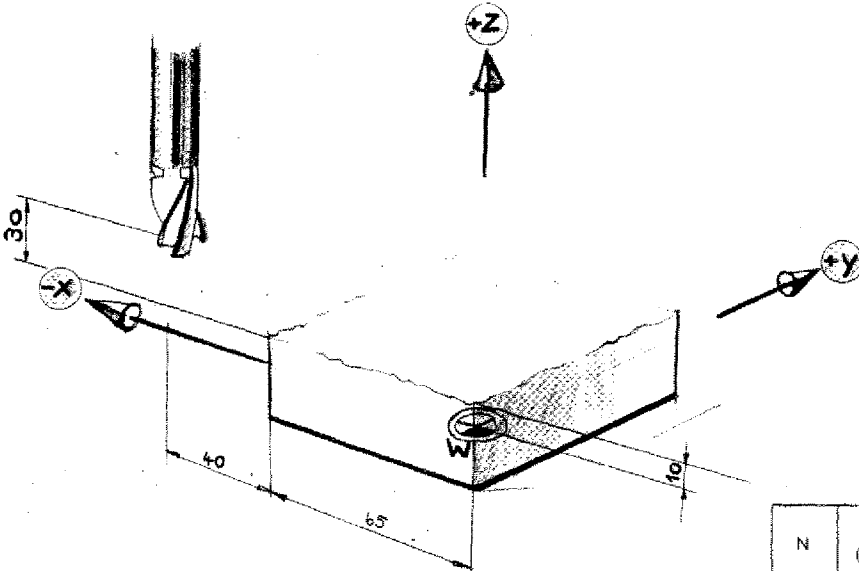

N	G (M)	X (J) (D)	Y (K) (S)	Z	F (L) (T) (H)

Exercises

Program the workpiece zero-point

Program the indicated traverse paths.

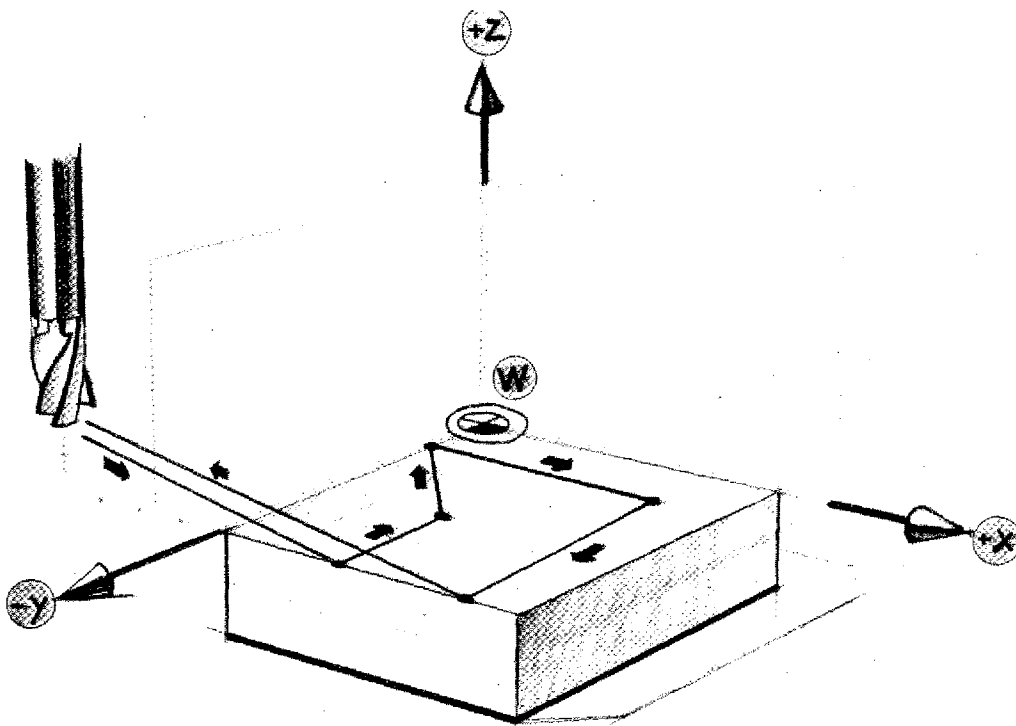

N	G (M)	X (J) (D)	Y (K) (S)	Z	F (L) (T) (H)

Various Workpiece Zero-Points in one Program

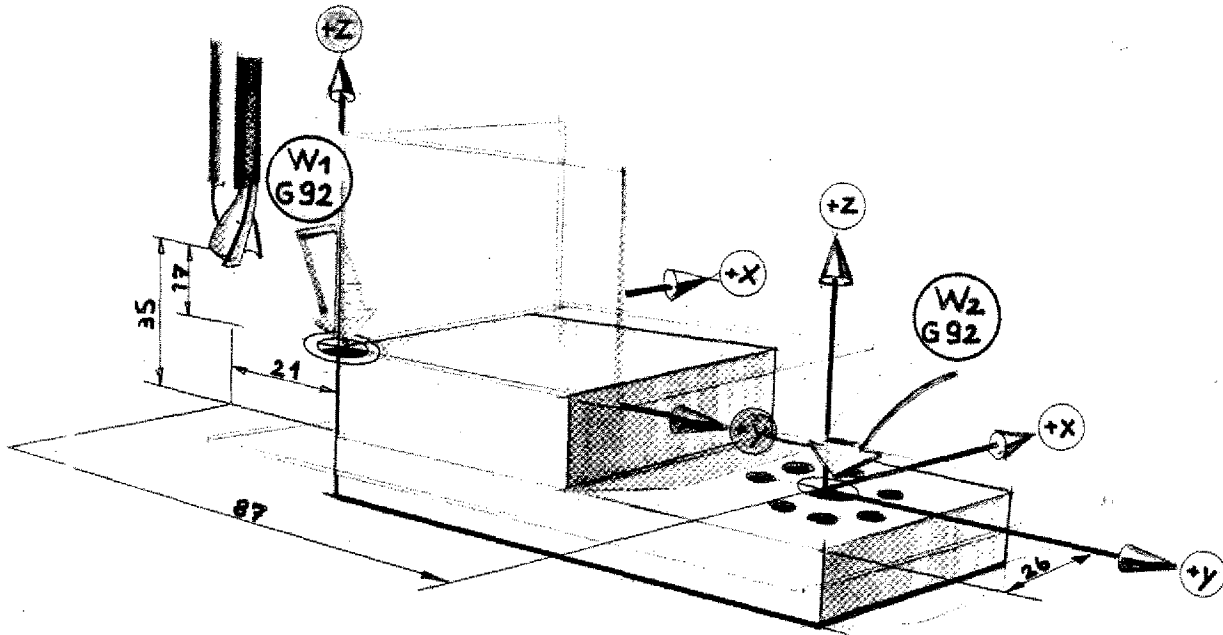

$W_1 : G92 / x - 2100 / y = 0 / z 1700$
 $W_2 : G92 / x - 8700 / y - 2600 / z 3500$

By a new programming of the workpiece zero-point the previous workpiece zero-point is cancelled.

Sometimes it is easier for the programming to set various workpiece zero-points within one program.

Example:

- W1 is programmed. Plane 1 is worked on.
- Traverse cutter to starting position.
- W2 is programmed. Plane 2 is worked on.

Note:

In most cases it is best to program the reference point offset from one and the same point so that the program stays distinct.

Mixed Programming

You may change also within one and the same program the programming mode from absolute to incremental, and vice-versa.

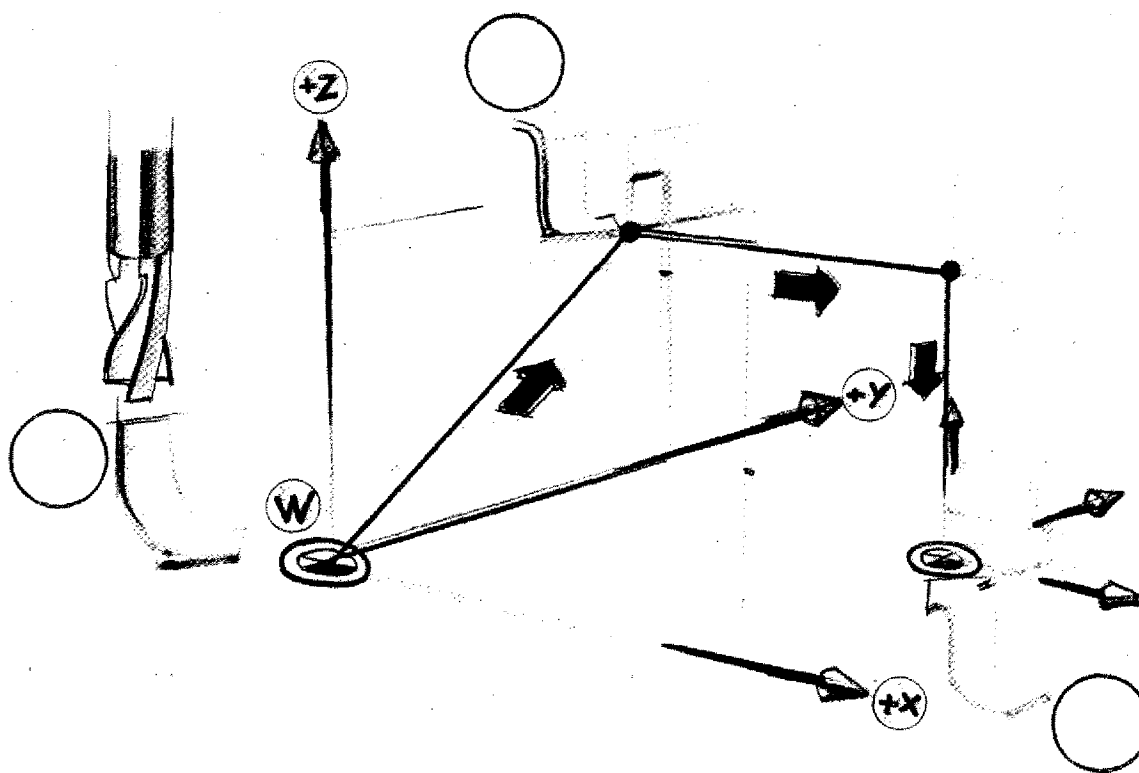

Programming of the originally fixed workpiece zero-point

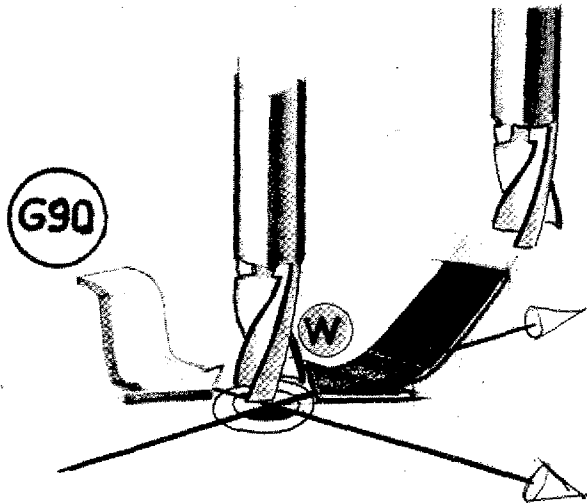

If you want to fix the originally programmed workpiece zero-point you have to either

- move the tool into the original workpiece zero-point and then program G90

or

- describe from the original workpiece zero-point the actual cutter position.

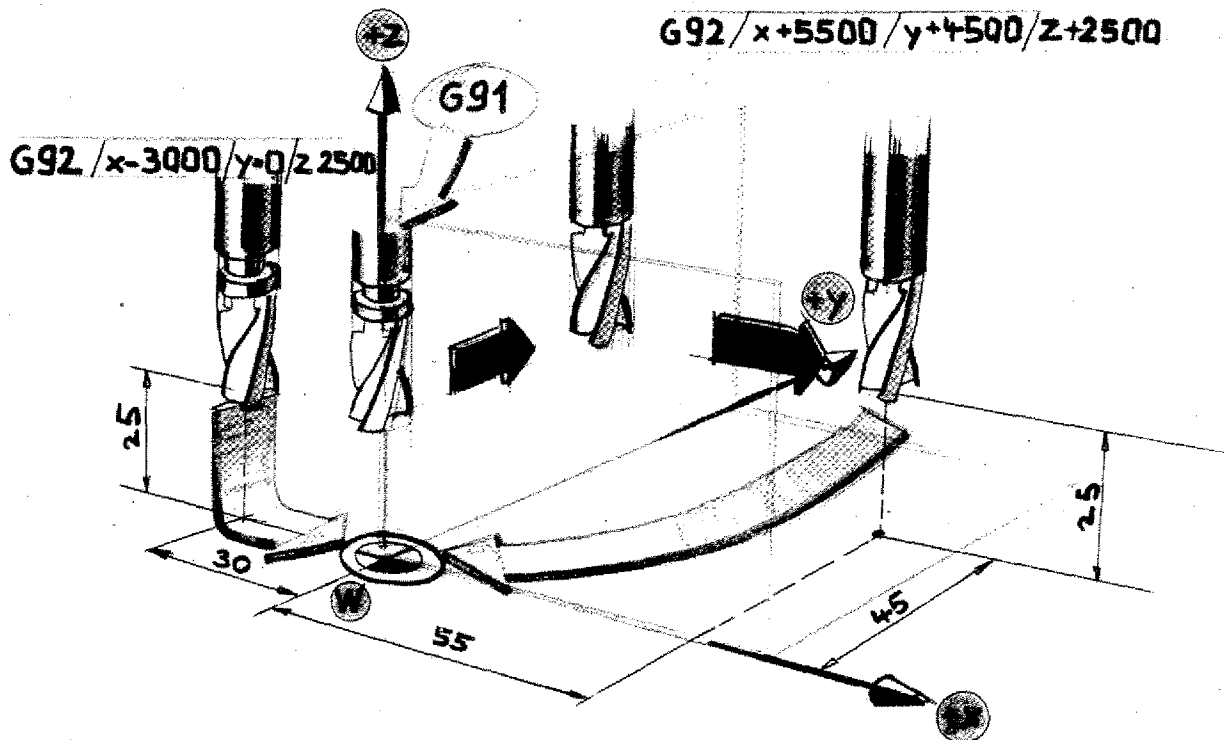

Connection:

G92 – Zero-point offset

M06 – Tool lengths compensation

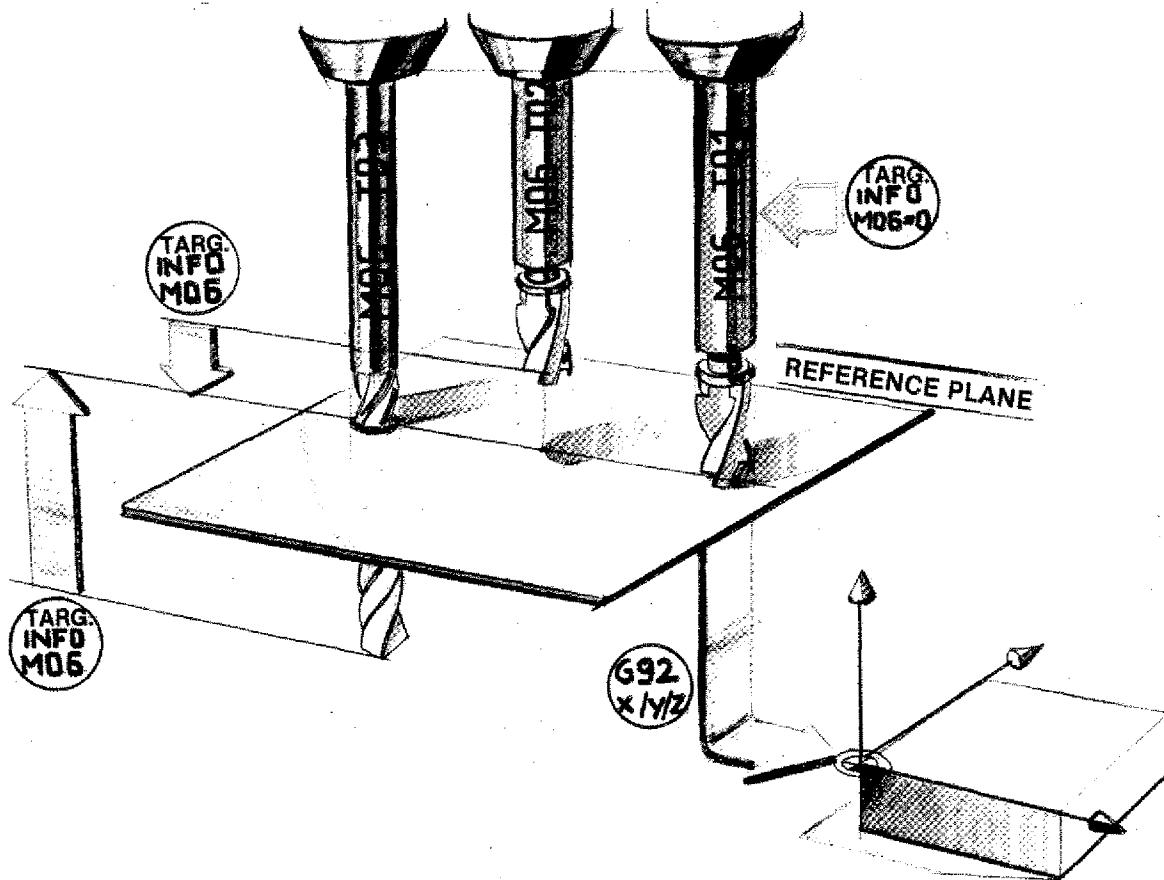

M06

The HZ information is an incremental target information within an independent coordinates system.

G92

With G92 you fix the origin of the coordinates system.

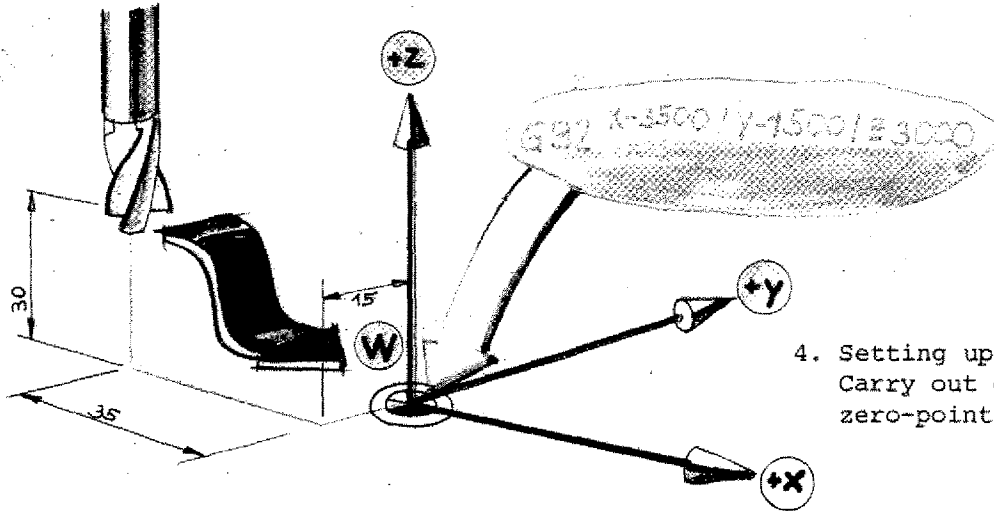

4. Setting up the program:
Carry out offsetting of workpiece ch-zero-point

Manufacture

1. Mounting the workpiece

We assume that you have to manufacture a few workpieces of same shape. You mount the workpiece such that it is always in the same position on the machine table.

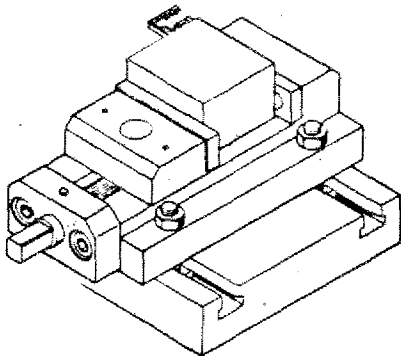

- The machine vice is clamped.
- In Y-direction the workpiece remains always in same position because of the unmovable jaw.
- In X-direction by a stop,
- In Z-direction by identical spacers.

2. You scratch the three reference surfaces and move the tool to the program start point (= program end point, = tool change point).

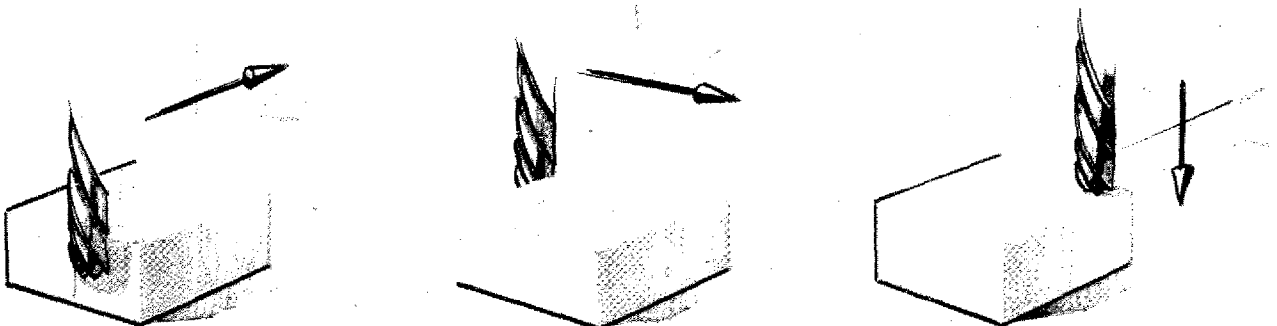

Some tips for procedure

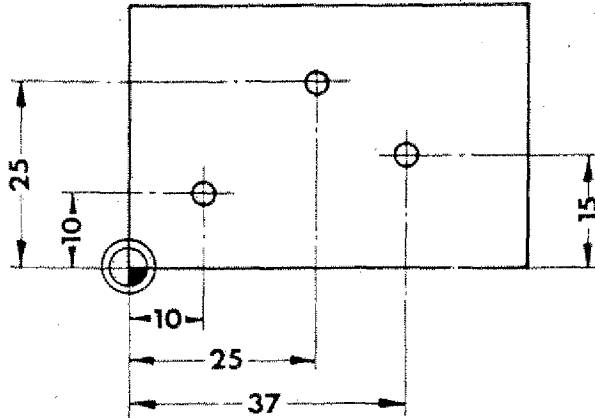

1. Determining the workpiece zero-point in the drawing:

You can see in your workpiece drawing what the best position for the workpiece zero-point will be. You determine the workpiece zero-point in your drawing.

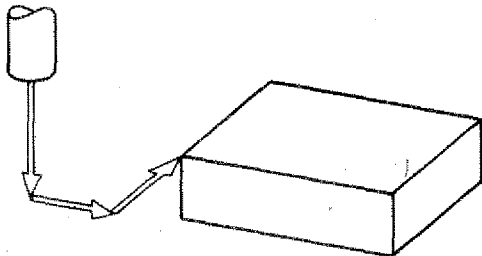

2. Determining the starting point of the program.

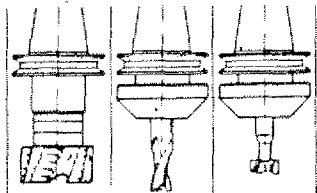

d	40	10	16
$D = \frac{d}{2}$	20	5	8
F	80	160	40
t	0,7	5	8
S	1100	2000	2000
HZ	0	650	-320
HZK			

3. Measuring of tools - Putting in data into a data sheet if more tools are used.

The Miscellaneous or Switching Functions M-Functions

Switching operations are programmable too on CNC-machines. The M-address is used to program them. The word for the miscellaneous functions contains a 2-digit key number.

Extract from codes for miscellaneous functions
(DIN 66025, part 2)

Miscellaneous Function	Meaning
M00	Programmed stop
M01	Optional (planned) stop
M02	End of program
M03	Spindle clockwise
M04	Spindle counterclockwise
M05	Spindle off
M06	Tool change
M07	Coolant no. 2 ON
M08	Coolant no. 1 ON
M09	Coolant off

Miscellaneous Function	Meaning
M10	Clamp
M11	Unclamp
M19	Oriented spindle stop
M30	End of program
M31	Interlock bypass
M48	
M49	
M58	Constant speed on
M59	Constant speed off
M60	Workpiece change

All key numbers not mentioned are temporarily or permanently available. The manufacturer of the control can assign the key numbers to a given function.

Miscellaneous or Switching Functions
on the F1-CNC

N	G (M)	X (J,D)	Y (K,S)
	M00		

Programming

The M key numbers are entered into the G-column.

So if there is a M-key number to be entered always add the letter M.

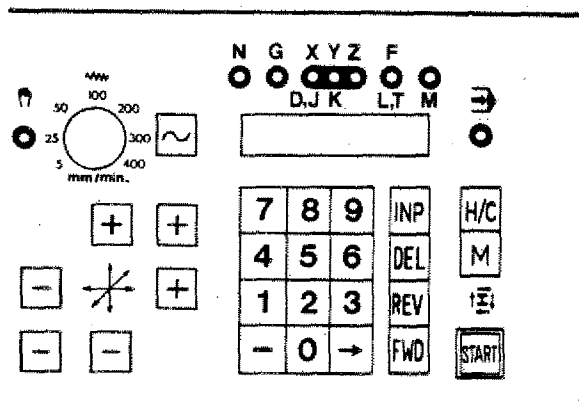

Input of M-values

Press M-key then put in number value.

M-Functions in standard version on F1-CNC

- M00 - Programmed stop
- M30 - Program end with re-set
- M06 - Tool lengths compensation
Tool data
Tool change
- M17 - Jump back instruction
- M99 - Circle parameter

M-Functions with the DNC-Interface (accessory)

- M03 - Spindle clockwise
- M05 - Spindle counterclockwise

- M08
 - M09
 - M20
 - M29
 - M22
 - M23
- Freely available M-functions

Description of Block Formats

Depending on the G-functions you have to program different addresses (enter values for N, X, Y, Z, F, M, T, D, S, L, J, K into the columns).

For a better overview the single prescriptions are abbreviated.

1. You need a block number N

This block number can be 3-digit.
Abbreviation: N3

2. The G-address

The G-address has two decades; it determines which addresses have to be programmed.

3. X, Y, Z-addresses

X, Y, Z addresses may have \pm signs.

Vertical milling machine:

$X^{\pm 5}, Y^{\pm 4}, Z^{\pm 5}$

Horizontal milling machine

$X^{\pm 4}, Y^{\pm 5}, Z^{\pm 4}$

4. F-address (feed)

3 digits, therefore T3

5. J, K-addresses (circle parameter)

2 digits, therefore J2, K2

6. M-address (auxiliary function)

2 digits, therefore M2

7. T-address (tool number)

3 digits, therefore T3

8. D-address (cutter radius)

5 digits, therefore D5

9. S-address (speed)

4 digits, therefore S4

10. L-address (jump)

3 digits, therefore L3

11. H-address (with M26)

3 digits, therefore H3

Example of a format description:

Format G00

N3/G00/X \pm 5/Y \pm 4/Z \pm 5

Types of Controls of CNC-Machine Tools

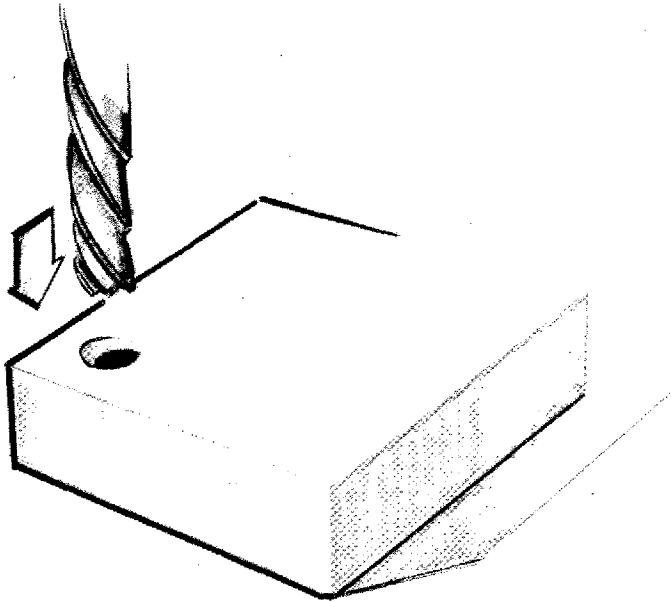

1. Point-to-Point Control

- The tool can move only from point to point.
- The speed of the tool movement is not registered.
- The tool path from point to point is not prescribed. Only the final position has to be correct.

Application:

Drilling machines, spot welding machines. Today rather seldom in use, because most controls offer straight line or contouring characteristics at the same price.

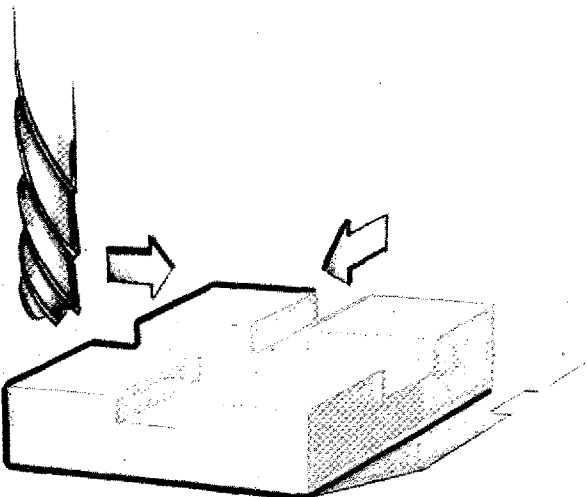

2. Straight Line Control

The tool moves with

- given speed
- axis parallel.

During the traverse movement milling is possible.

With milling machines either

- the longitudinal slide or
- the cross slide or
- vertical slide moves, but never two slides together!

Application:

Today hardly in use anymore; replaced by contouring control.

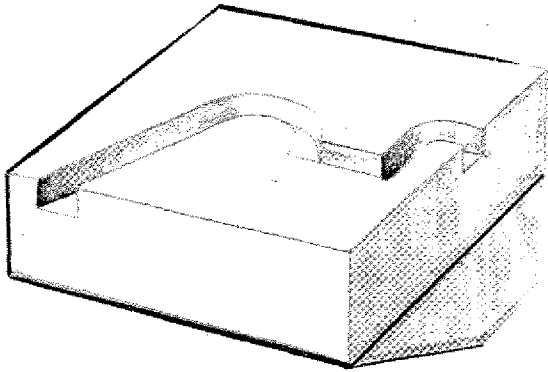

3. Contouring Control

Various axes traverse simultaneously with a programmed feed speed on a prescribed path. The movement can be a straight line or circular movement. Nearly all CNC-machine tools are today equipped with a contouring control.

Types of Contouring Controls

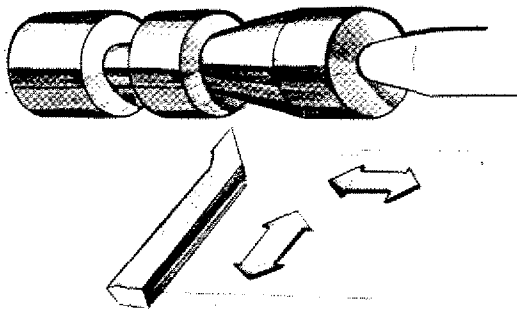

a) Two-Axes Contouring Control

(2D control; 2D means two-dimensional)

Application:
Lathes, simple milling machines, erosion machines, drawing machines, punch presses, etc.)

b) Two and a half Axes contouring Control

Three times 2 axes can be moved simultaneously with programmed feed speed and this on a prescribed path.

The illustrations are there to show you what is meant by three times 2 axes.

Application:
Milling machines, machining centers,
flame cutting machines, etc.

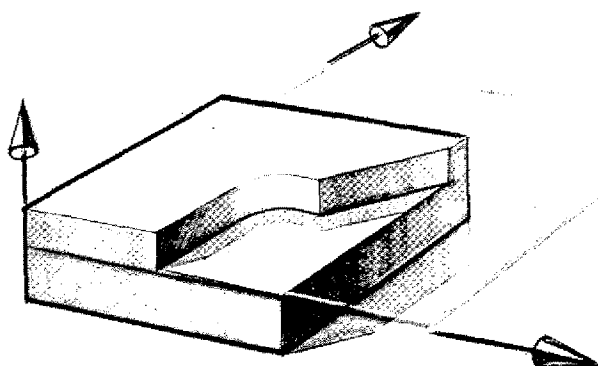
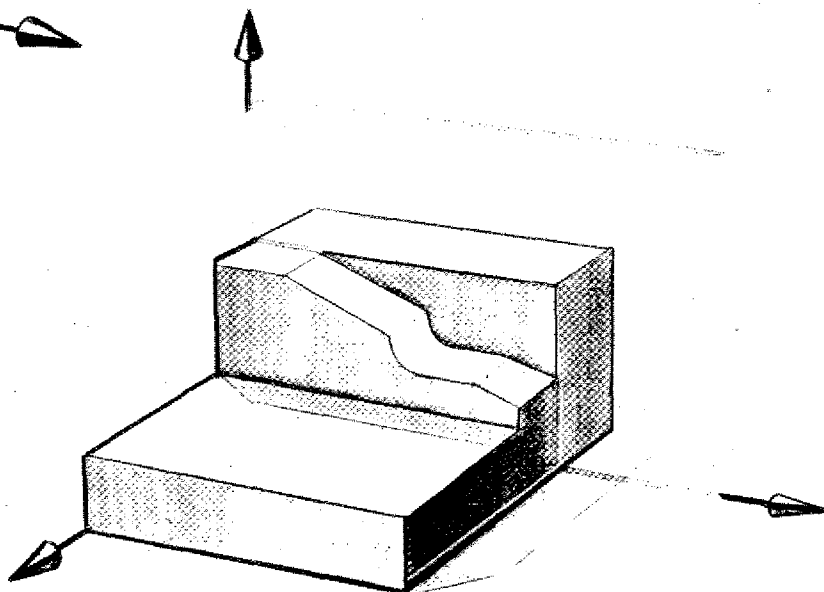
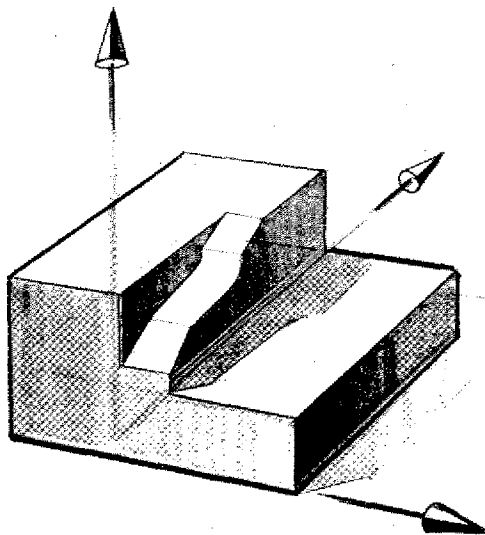

c) Three-Axes Contouring Control

(3D control)

All three axes can traverse simultaneously on a prescribed path with programmed feed speed.

Application:

Milling machines for the production of complex three-dimensional workpieces. If you traverse in three axes simultaneously you need special milling cutters (round head cutters etc.).

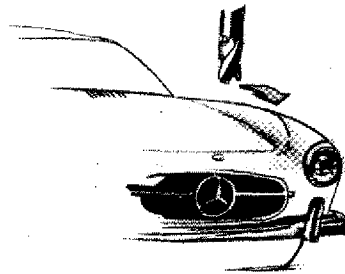

Note:

There are misunderstandings caused by commonly used technical terms. A milling machine features 3 directions of movements:

- longitudinal slide movement
- cross slide movement
- vertical movement (up and down)

This is called a 3-axes machine. However, this does not imply that the machine is equipped with a 3D contouring control (3-axes contouring control).

Programming – Geometry

- The center point path of the cutter
 - influence of the cutter radius
- Trigonometry of the right triangle
- CNC conformal lettering, calculation of missing coordinates
- Transitions straight line – circular arc tangent
- Calculations of auxiliary points
 - Straight line
 - Circular arc tangent

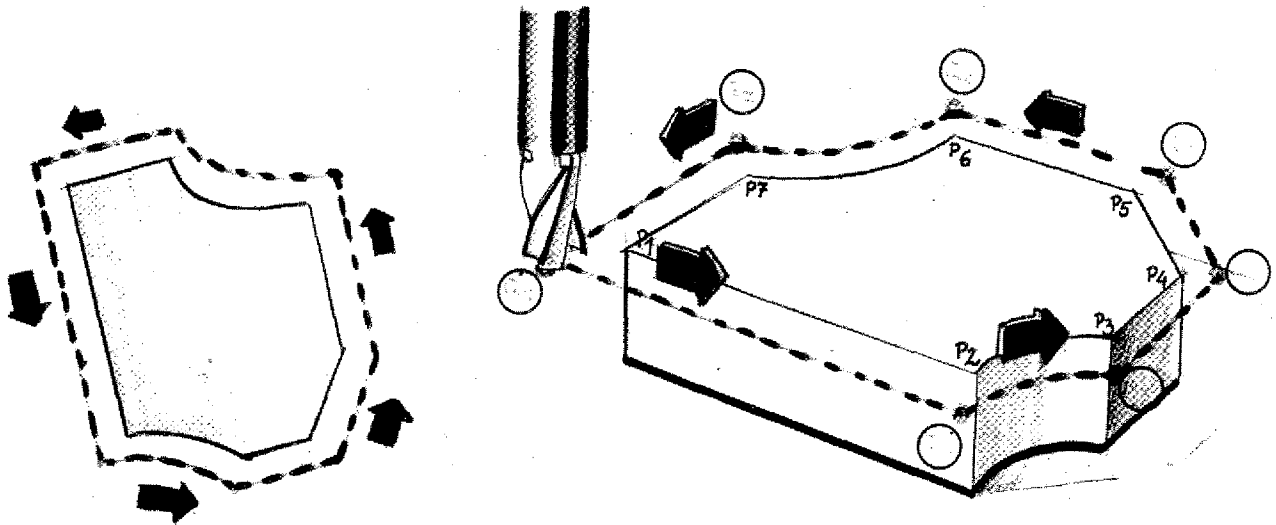

Description of the cutter path

We describe the center point path of the cutter (except G72, G45-G48)

Influence of the cutter radius:

When milling contours the cutter diameter determines the programming of the cutter path.

Auxiliary points:

When programming the center points of the cutter path the target points are called auxiliary points.

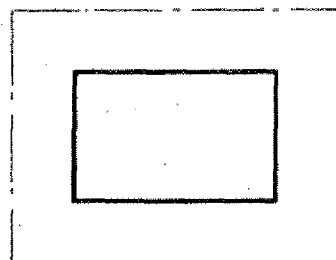
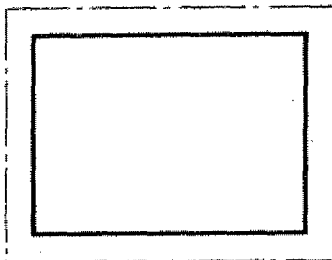
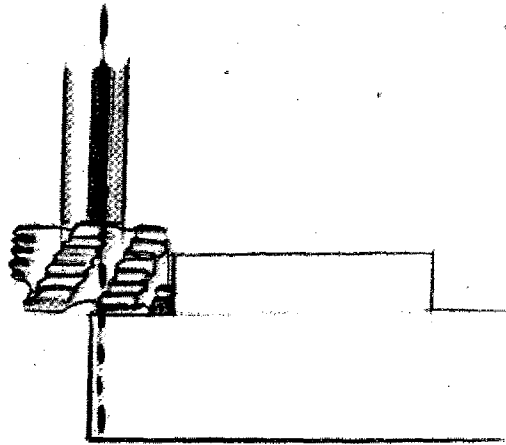
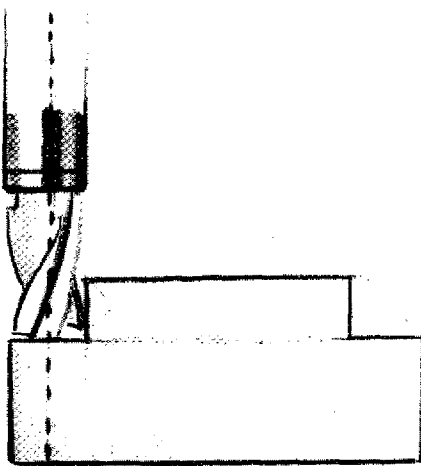

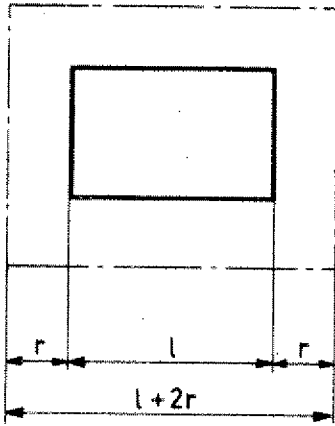

When manufacturing axis-parallel contours the cutter radius has to be added to or subtracted from the contour.

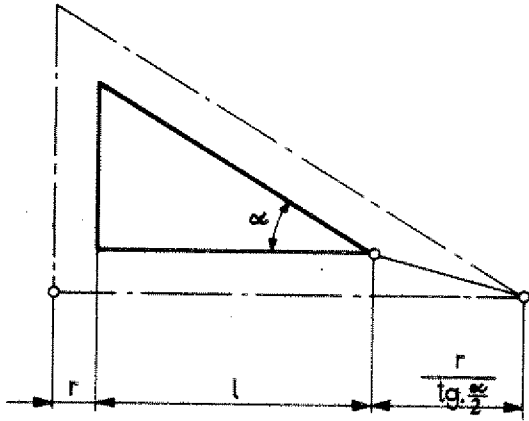

With non-axis parallel contours, auxiliary points have to be calculated. For this the trigonometric functions of the right triangle will do.

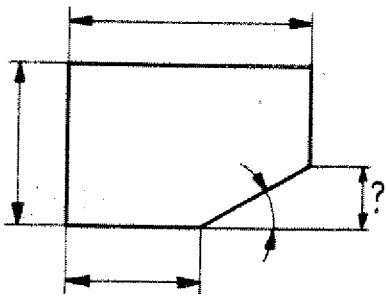

In quite some cases the coordinates of crossing points have to be calculated because they are not indicated in common technical drawings. Missing coordinates are calculated on the basis of trigonometric functions.

Survey

Trigonometric functions in the right triangle

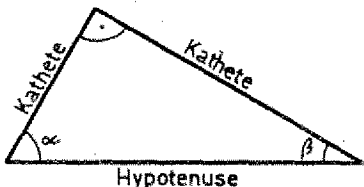

Specification:

The right angle (90°) is characterized with the symbol \square .

Both angles α (Alpha) and β (Beta) are in sum 90° .

$$\alpha + \beta = 90^\circ$$

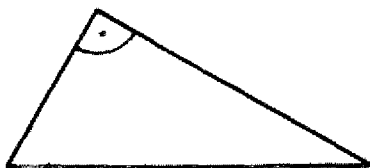

Hypotenuse:

Opposite side of right angle.

Abbreviation: HY

Adjacent side (AS), opposite side (OS):

Each angle α and β has a adjacent side and a opposite side.

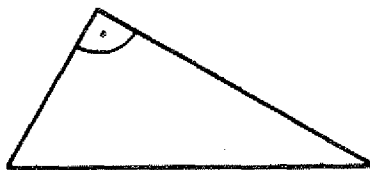

Adjacent side = adjacent side to angle α or β

Opposite side = opposite side to angle α or β

	$\text{Sine} = \frac{GK}{Hy}$	$\sin \alpha = \frac{a}{c}$	$a = c \cdot \sin \alpha$ $c = \frac{a}{\sin \alpha}$
	$\text{Cosine} = \frac{AK}{Hy}$	$\cos \alpha = \frac{b}{c}$	$b = c \cdot \cos \alpha$ $c = \frac{b}{\cos \alpha}$
	$\text{Tangent} = \frac{GK}{AK}$	$\tan \alpha = \frac{a}{b}$	$a = b \cdot \tan \alpha$ $b = \frac{a}{\tan \alpha}$
	$\text{Cotangent} = \frac{AK}{GK}$	$\cot \alpha = \frac{b}{a}$	$b = a \cdot \cot \alpha$ $a = \frac{b}{\cot \alpha}$

CNC-Conformal Lettering The Calculation of Coordinates

In many cases the lettering of technical drawings is such that the coordinates for the CNC-programming have to be calculated.

Non CNC-conformal lettering

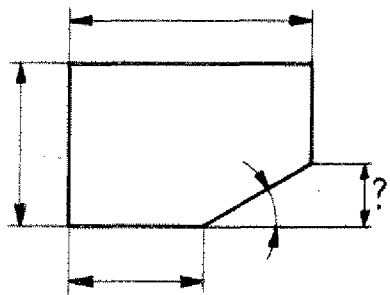
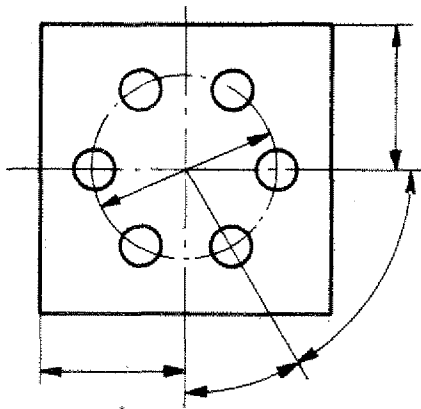

CNC-conformal lettering

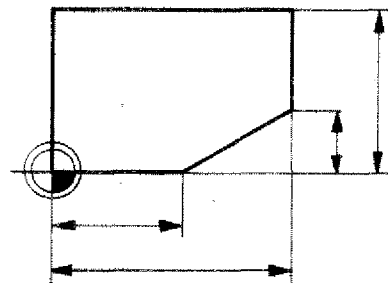
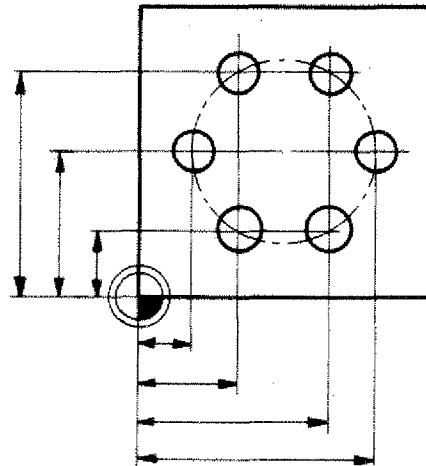

Missing coordinates data can mostly be calculated using simple trigonometric functions.

Calculation of Coordinates

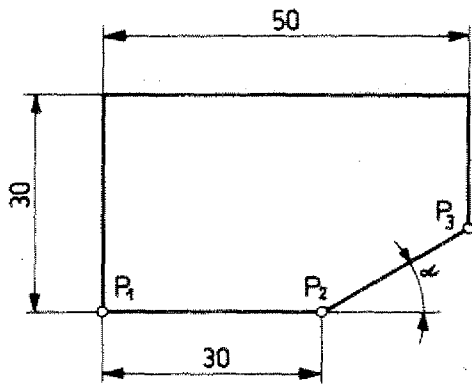

Transitions: Axis-parallel straight line – straight line at angle

The Y-coordinate of point P_3 is not known.

$$\operatorname{tg} \alpha = \frac{Y(P_2 P_3)}{20}$$

$$\begin{aligned} Y(P_2 P_3) &= \operatorname{tg} \alpha \cdot X(P_2 P_3); \alpha = 30^\circ \\ &= \operatorname{tg} 30^\circ \cdot 20 = 11,54 \text{ mm} \end{aligned}$$

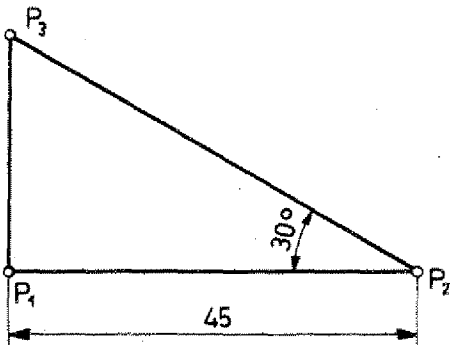

Exercise:

Calculate the missing coordinate of point P_3 .

Make a CNC-conformal drawing.

Transition straight line – tangential arc

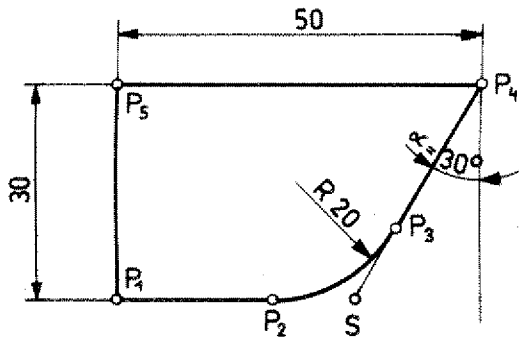

Coordinates of points P_2 , P_3 are not known.

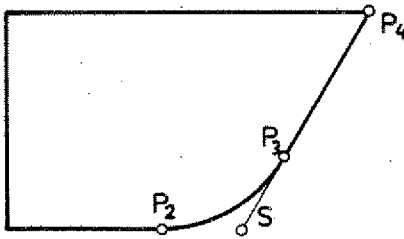

1. Calculate the X-coordinate of S (crossing point between straight line and slant plane)

$$\text{tg } \alpha = \frac{X}{30}$$

$$X = \text{tg } 30^\circ \cdot 30 = 17.32$$

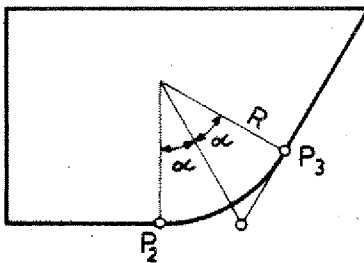

2. Calculate the X-coordinate of P_2 .

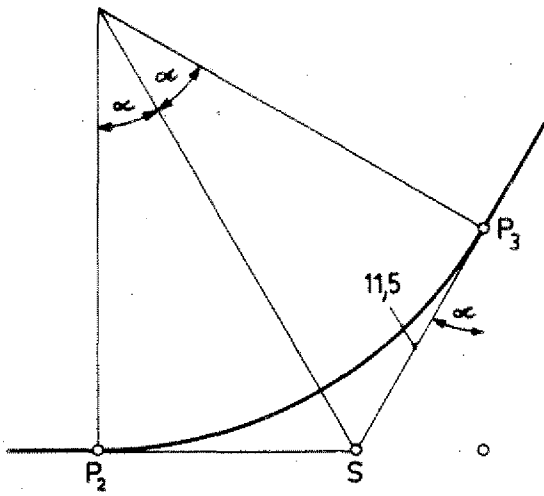

3. Calculate the X- and Y-coordinate of point P₃.

$$\overline{SP_3} = 11.55 \text{ mm}$$

$$\sin \alpha = \frac{X}{11.55}$$

$$X = \sin 30^\circ \cdot 11.55 = \underline{5.78 \text{ mm}}$$

$$\cos \alpha = \frac{Y}{11.55}$$

$$Y = \cos 30^\circ \cdot 11.55 = \underline{10 \text{ mm}}$$

Letter all points in absolute and incremental mode

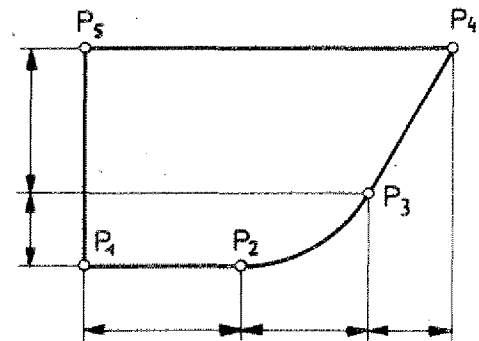
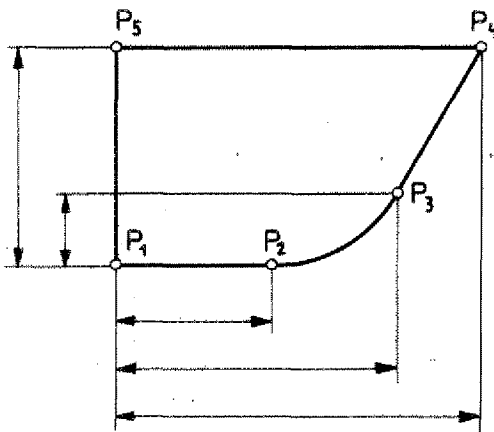

Calculation of auxiliary points

Example 1

You program the path of the milling axis
 $Q_0/Q_1/Q_2/Q_3 \dots$
 Points Q_1 and Q_2 have to be calculated.

Cutter dia. 10 mm.

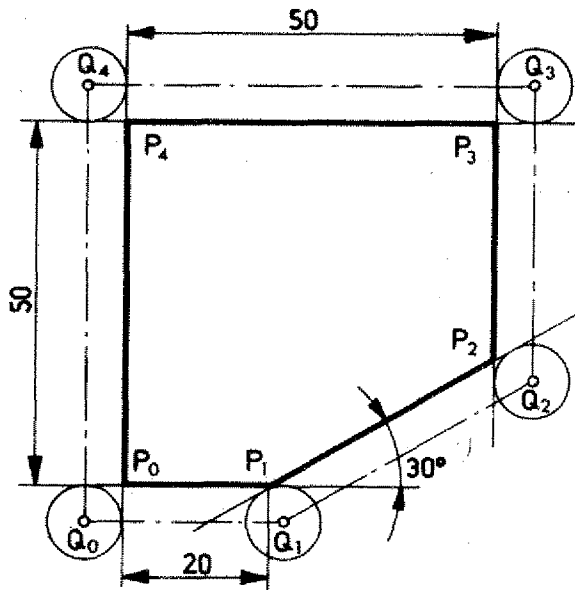

1. Calculate the Y-coordinate of point P_2 .

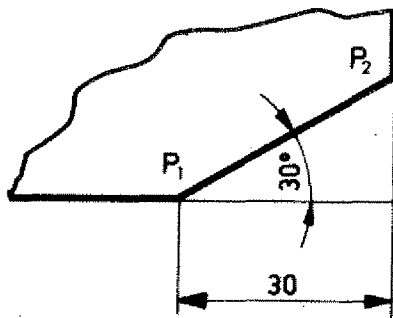

$$\text{tg } 30^\circ = \frac{YP_2}{30}$$

$$YP_2 = 30 \cdot \text{tg } 30^\circ = 17.32 \text{ mm}$$

Example 1 (continued)

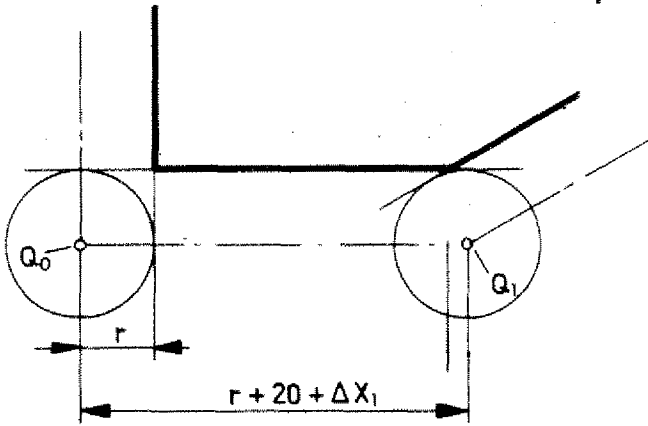

2. The path from Q_0 to Q_1 is composed of:

$$r + 20 \text{ mm} + \Delta X_1$$

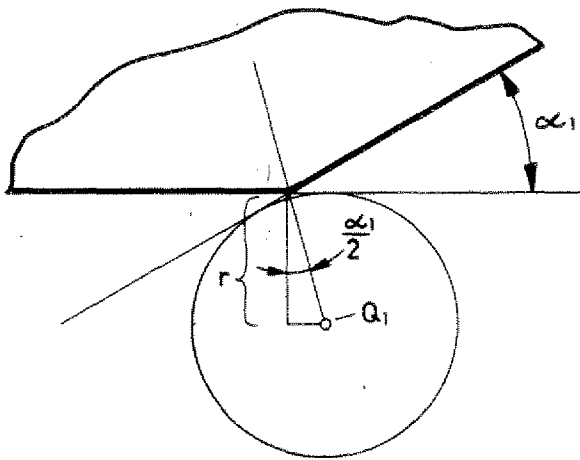

$$\text{tg } \frac{\alpha_1}{2} = \frac{\Delta X_1}{r}$$

$$\begin{aligned} \Delta X_1 &= \text{tg } \frac{\alpha_1}{2} \cdot r = \\ &= \text{tg } 15.5^\circ \\ &= \underline{\underline{1,34 \text{ mm}}} \end{aligned}$$

$$Q_0Q_1 = 26,34 \text{ mm}$$

Coordinates: Q_0 = Workpiece zero-point

Q_0	X	Y
Q_0	0	0
Q_1	26,34	0
Q_2	60	

Example 1 (continued)

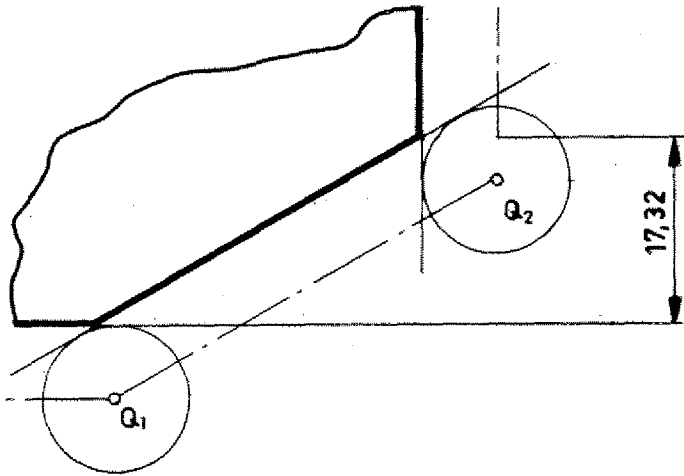

3. Calculation of Y_{Q2}

$$Y_{Q2} = 17,32 - \Delta Y_2$$

$$\text{tg} \frac{\alpha_2}{2} = \frac{\Delta Y_2}{r}$$

$$\Delta Y_2 = r \cdot \text{tg} \frac{\alpha_2}{2} = 5 \cdot \text{tg} 30$$

$$= 2,87 \text{ mm}$$

$$Y_{Q2} = 17,32 - 2,87$$

$$= 14,45 \text{ mm}$$

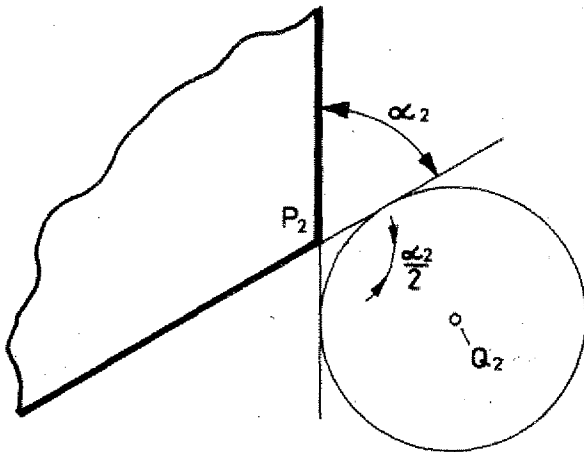

Dimension the auxiliary points in absolute and incremental mode. Fix the workpiece zero-point by yourself.

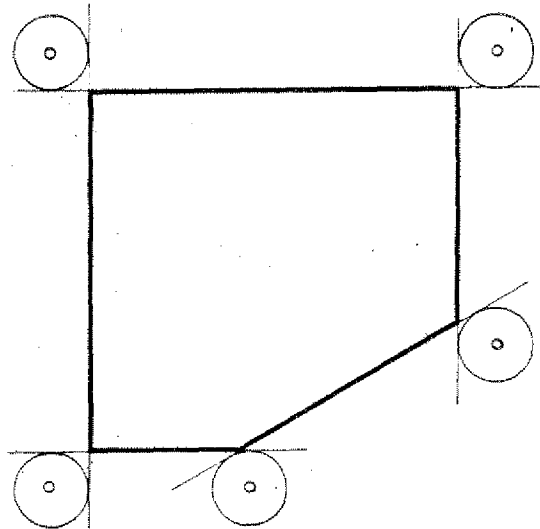
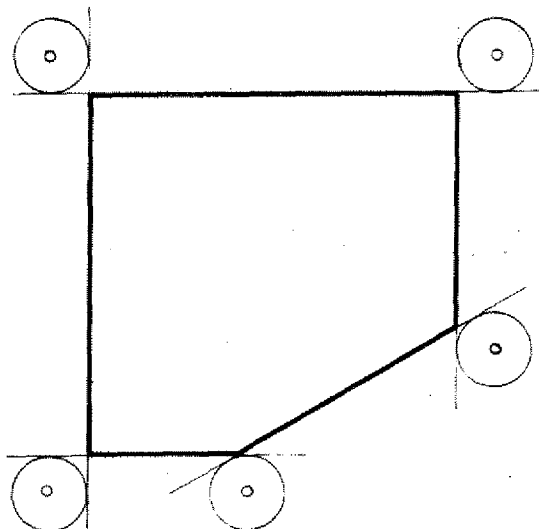

Exercise 1 (Calculation of auxiliary Points)

Calculate the ΔX and ΔY values.

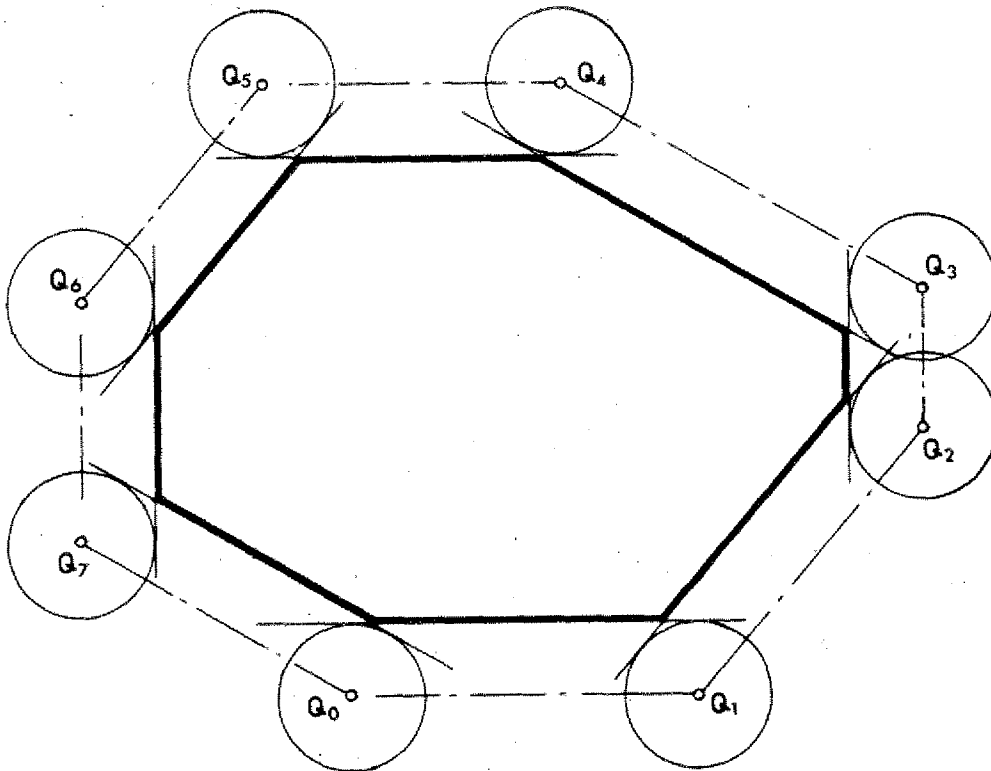
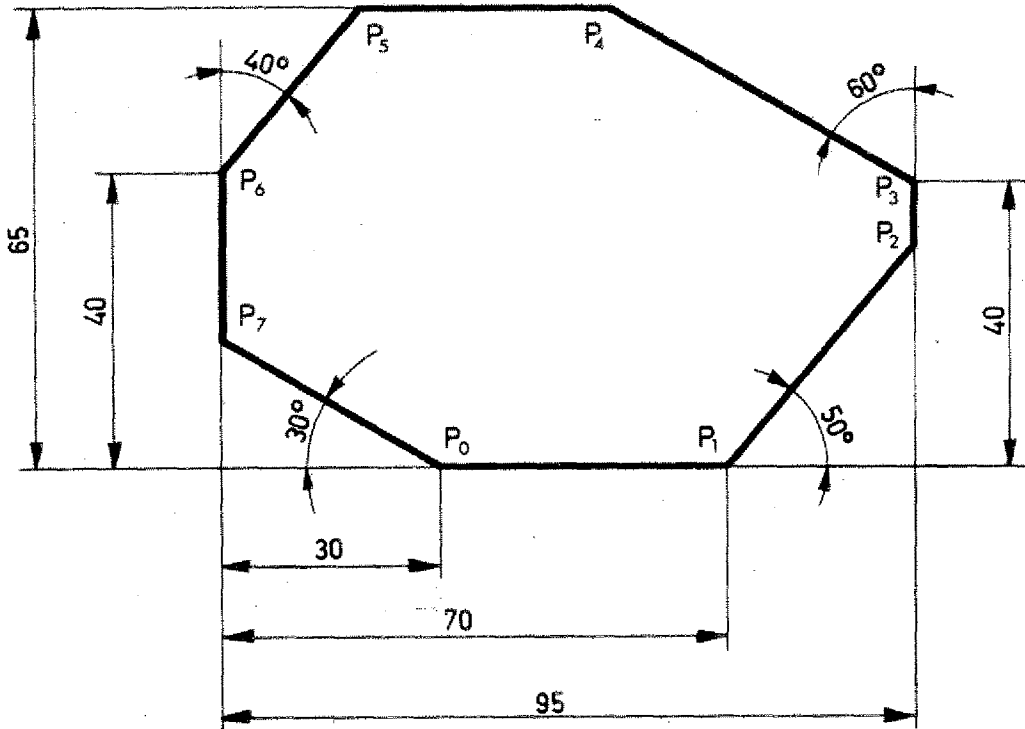

Exercise 1 (continued)

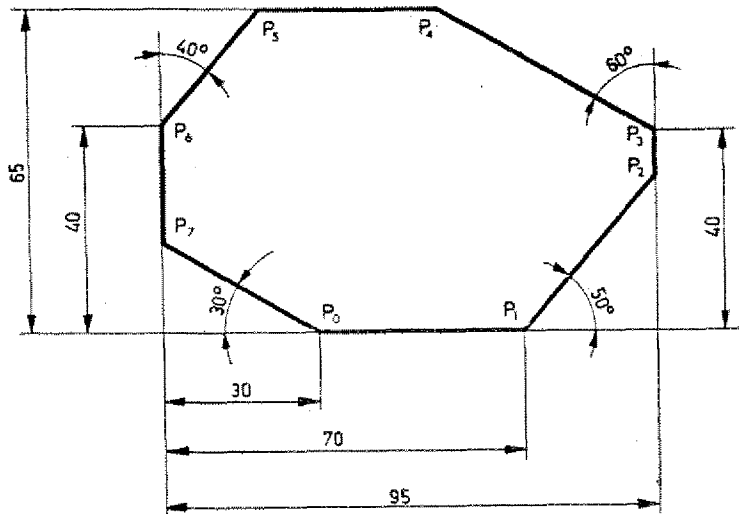

Dimension the auxiliary points in absolute mode. Workpiece zero-point as in drawing.

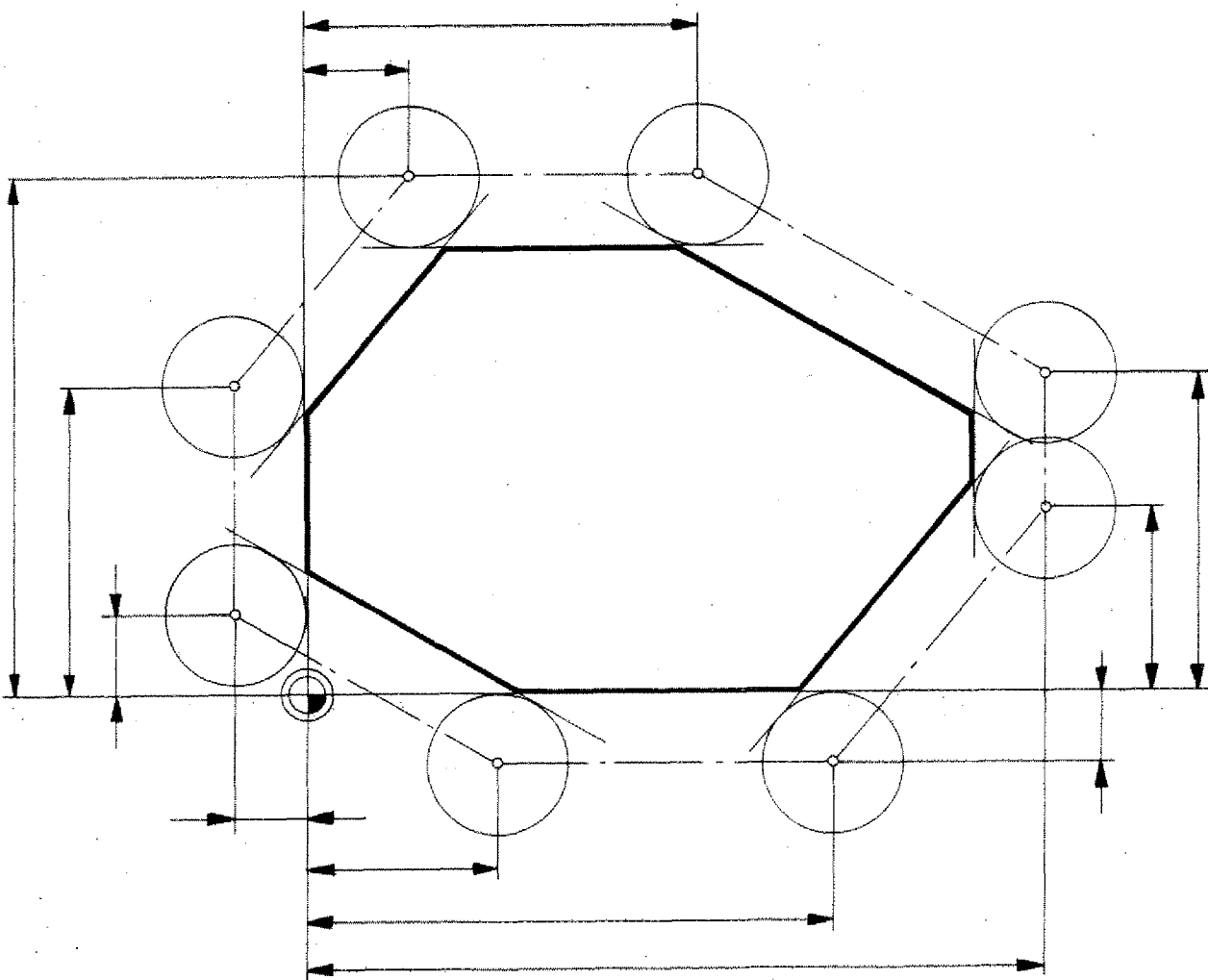

Exercise 1 (continued)

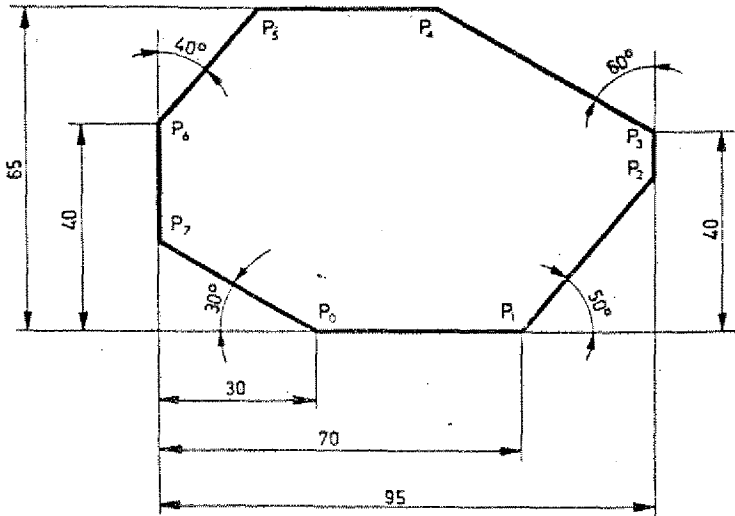

Dimension the auxilliary points in incremental mode.

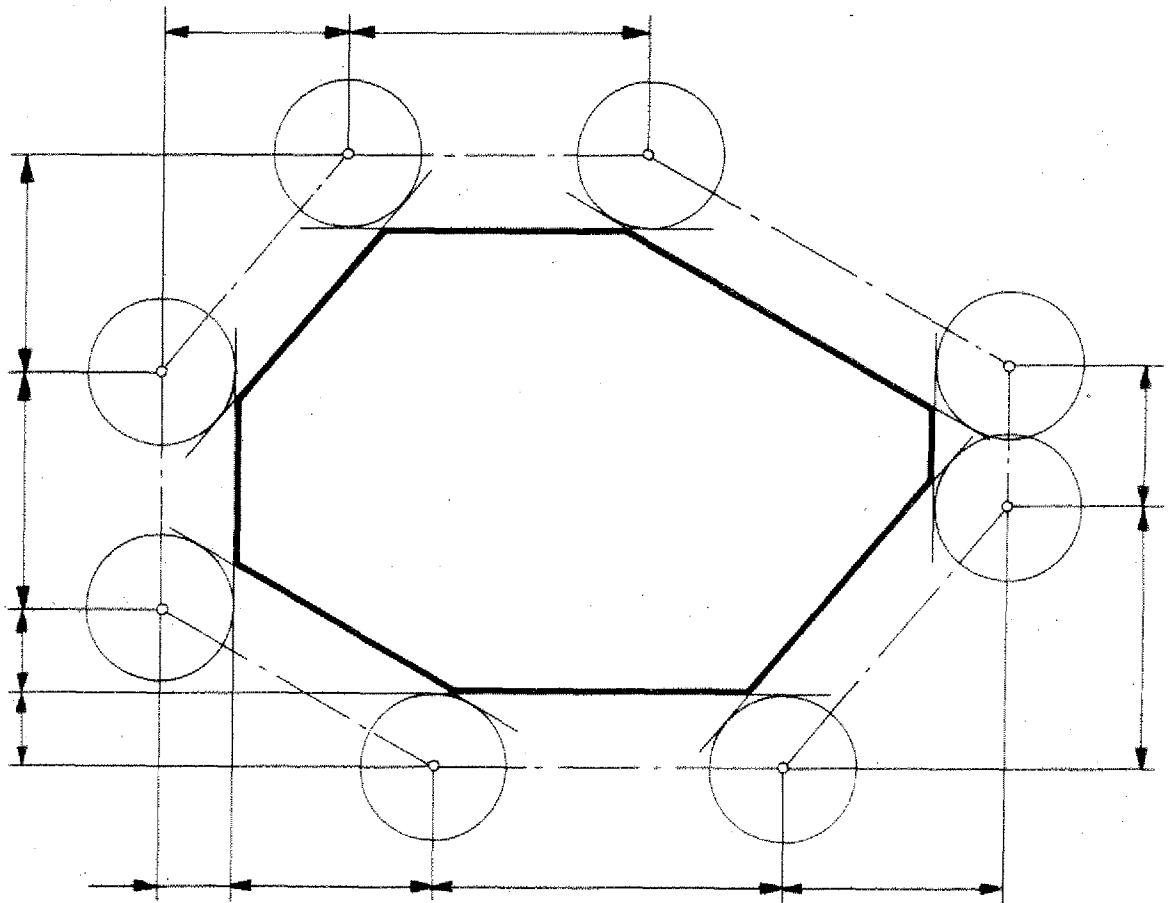

Exercise 2

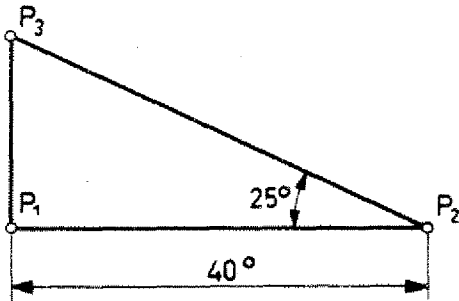

- Calculate the coordinate of point P_3 .

- Calculate the missing auxiliary coordinates.

Cutter radius 10 mm

- Pay attention: angle α_2 is given as interior angle (enclosed angle).

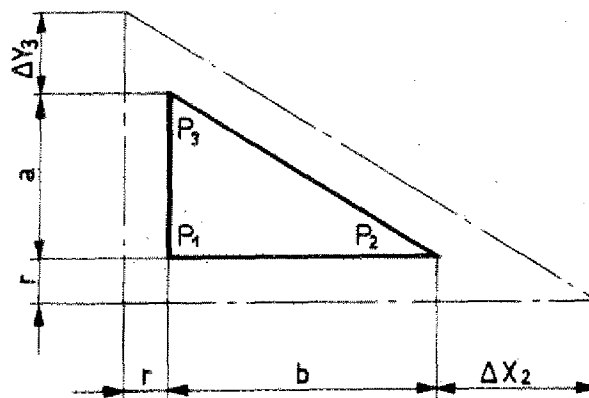
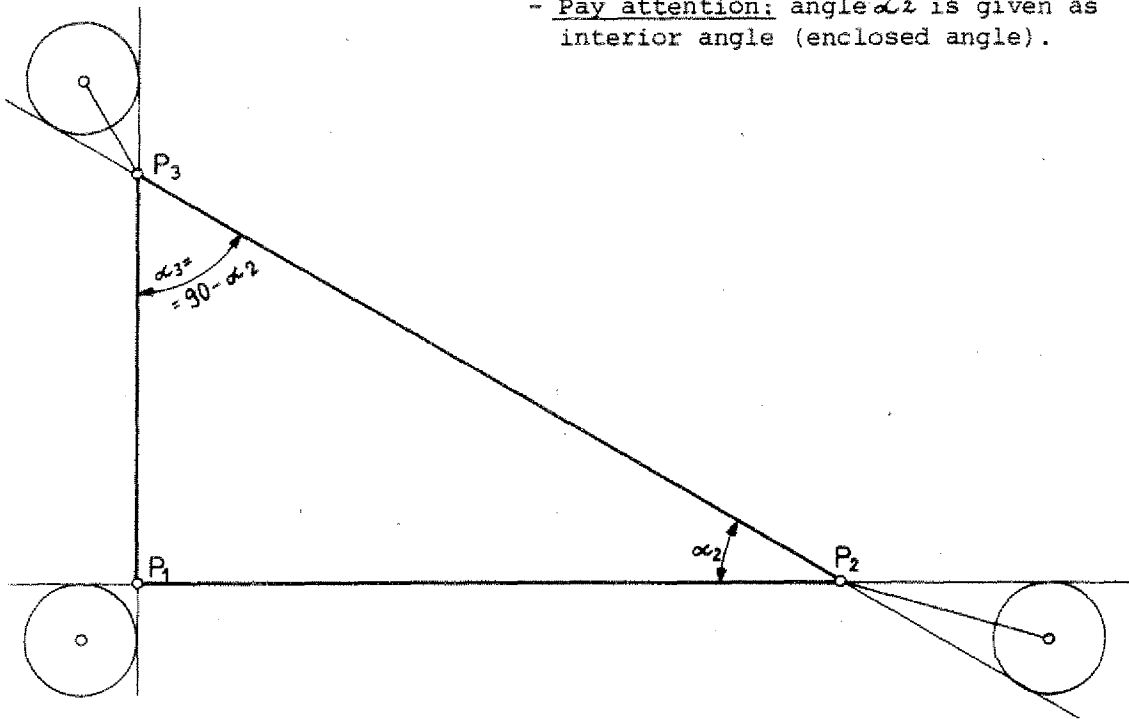

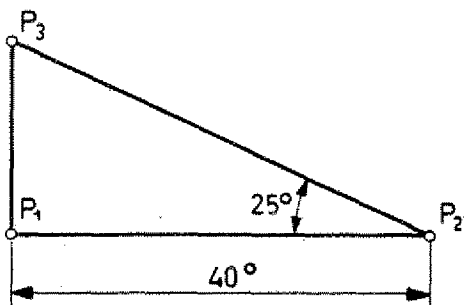
Exercise 3

Program the exercise in absolute or incremental mode.

Fix the workpiece zero-point and the cutter radius yourself.

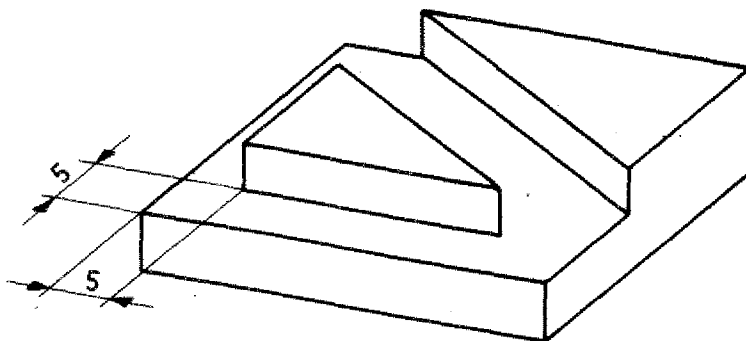

Example 2

Approach at angle

(A big safety distance was selected intentionally!)

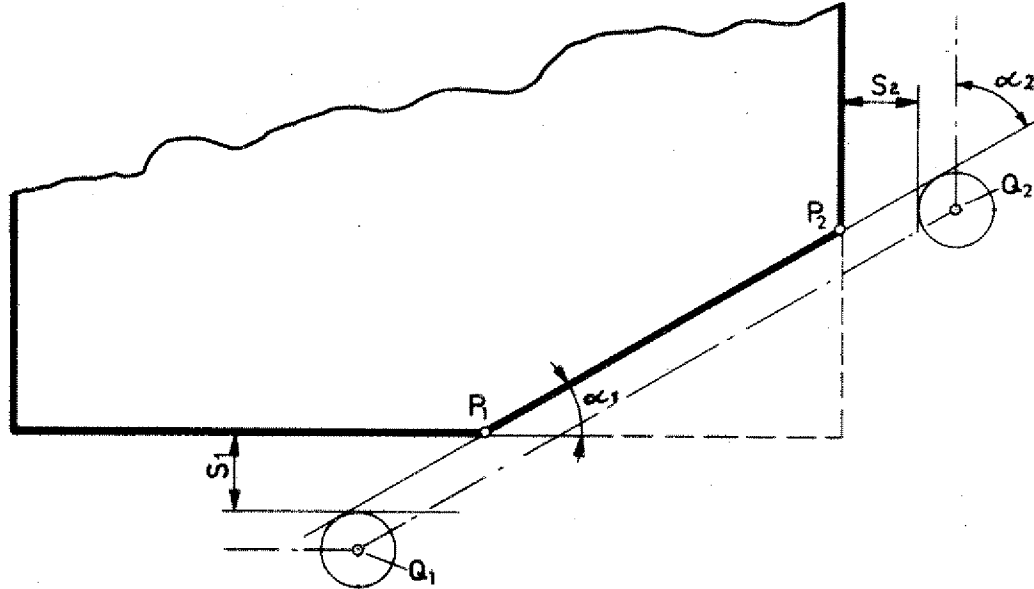

$$\alpha_1 = 30^\circ / \alpha_2 = 60^\circ$$

S_1 = Safety distance (10 mm)

r = Cutter radius (5 mm)

Calculation of point Q_1

1. X_1 :

$$\operatorname{tg} \alpha_1 = \frac{S}{X_1}$$

$$X_1 = \frac{S}{\operatorname{tg} \alpha_1} = \frac{10}{\operatorname{tg} 30^\circ} = 17,32 \text{ mm}$$

2. ΔX_1 :

$$\operatorname{tg} \frac{\alpha_1}{2} = \frac{\Delta X_1}{r}$$

$$\Delta X_1 = \operatorname{tg} \frac{\alpha_1}{2} \cdot r = \operatorname{tg} 15^\circ \cdot 5 = 1,34 \text{ mm}$$

3. Distance $Y(P_1Q_1) = S+r = 15 \text{ mm}$

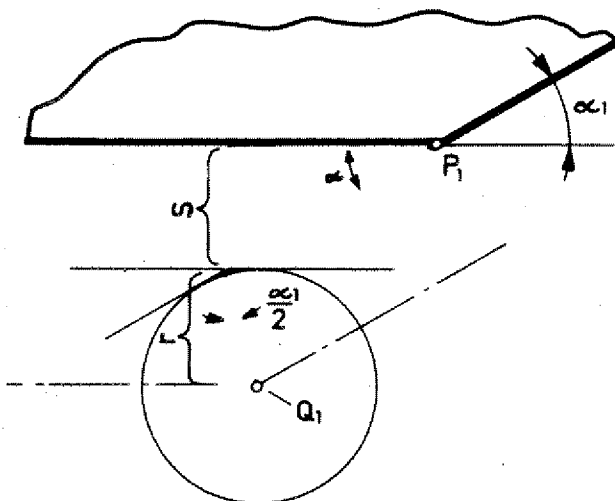

Example 2 (continued)

Calculation of point Q₂

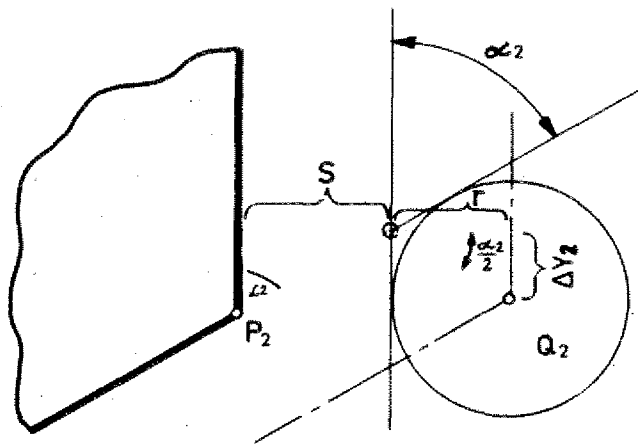

$$S_2 = 20 \text{ mm}$$

$$r = 5 \text{ mm}$$

$$\alpha_2 = 60^\circ$$

1. Y₂

$$\text{tg } \alpha_2 = \frac{S}{Y_2}$$

$$Y_2 = \frac{S}{\text{tg } \alpha_2} = \frac{20}{\text{tg } 60^\circ} = 11,55 \text{ mm}$$

2. ΔY₂

$$\text{tg } \frac{\alpha_2}{2} = \frac{\Delta Y_2}{r}$$

$$\Delta Y_2 = \text{tg } \frac{\alpha_2}{2} \cdot r = 2.89 \text{ mm}$$

Describe the coordinates from points Q₁, Q₂ in connection with P₁, P₂.

Auxiliary Points with acute Angles

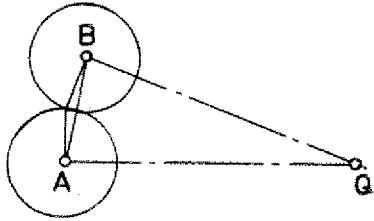

With acute angles you have to traverse long no-load paths from target point A to start point B.

That takes time. It may happen that the slide movements are too short or there is a collision with a chucking device or you mill into a workpiece part.

Two "short cuts" are common in milling techniques

Traverse with various straight lines.

Traverse with circular arc.

Traverse in circular arc

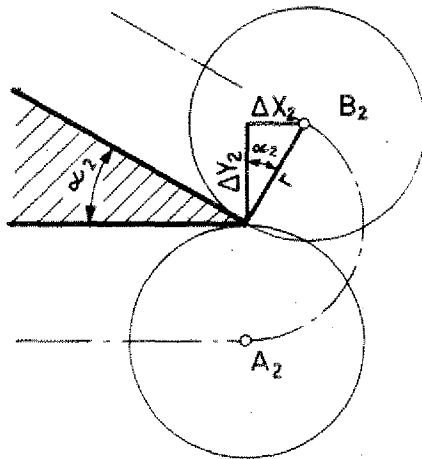
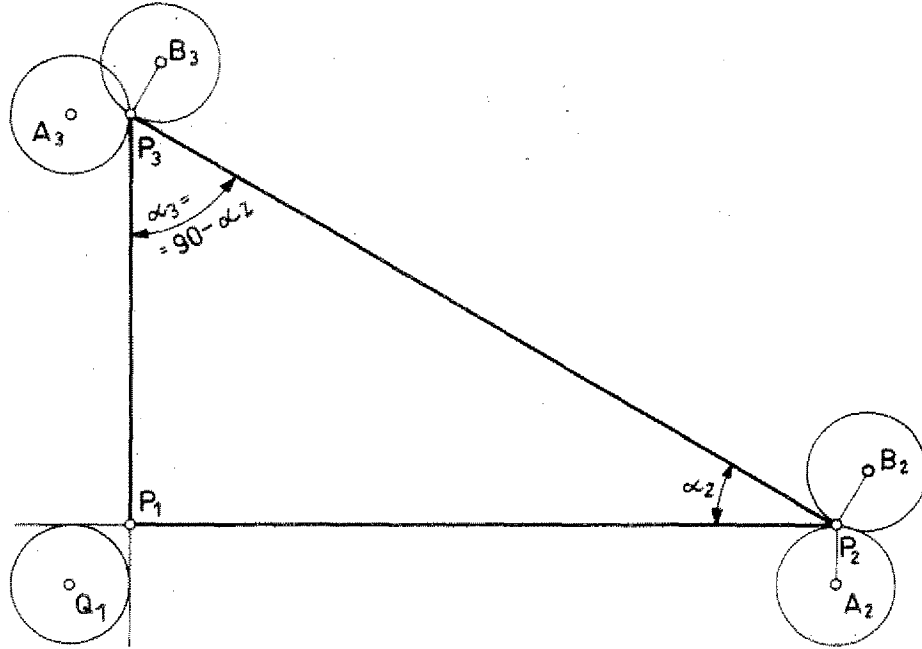

$$\sin \alpha_2 = \frac{\Delta X_2}{r}$$

$$\cos \alpha_2 = \frac{\Delta Y_2}{r}$$

$$\Delta X_2 = \sin \alpha_2 \cdot r$$

$$\Delta Y_2 = \cos \alpha_2 \cdot r$$

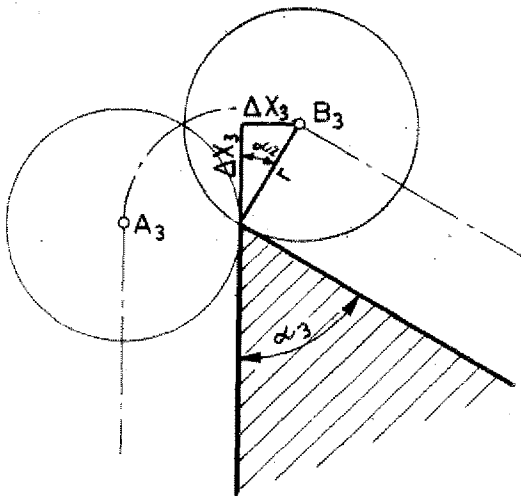

Traverse in circular arc

Exercise:

Dimension auxiliary points absolute at

Program absolute and incremental.

Select workpiece zero-point. ind

Program absolute and incremental.

Select workpiece zero-point.

$$P_1 P_2 = 40 \text{ mm}$$

$$\alpha_2 = 30^\circ$$

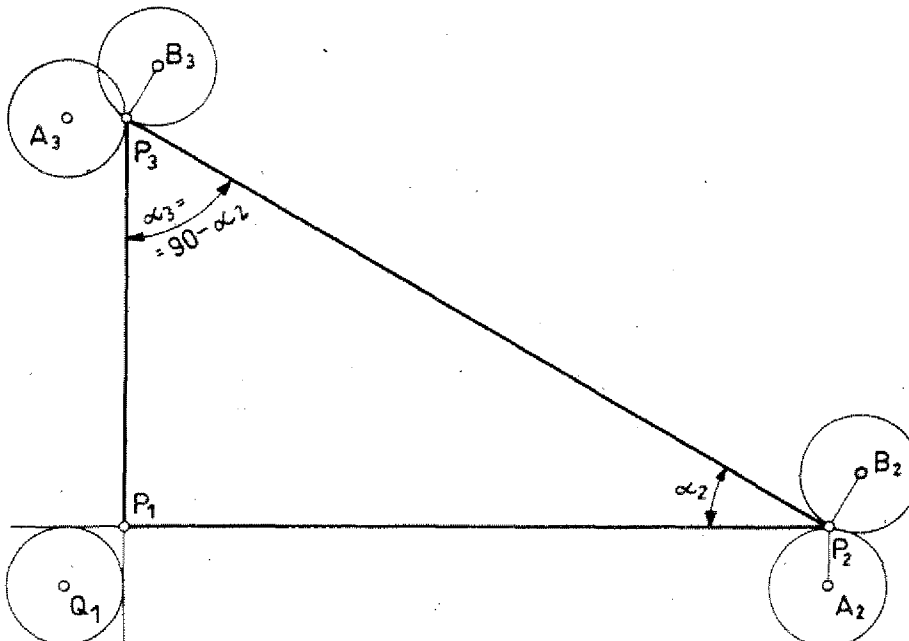
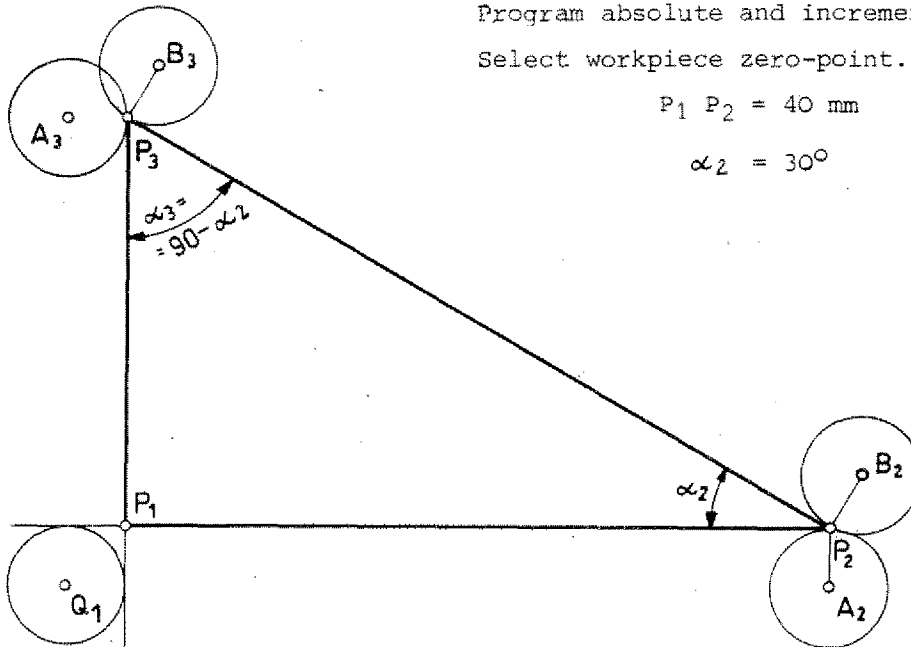

Straight line movement

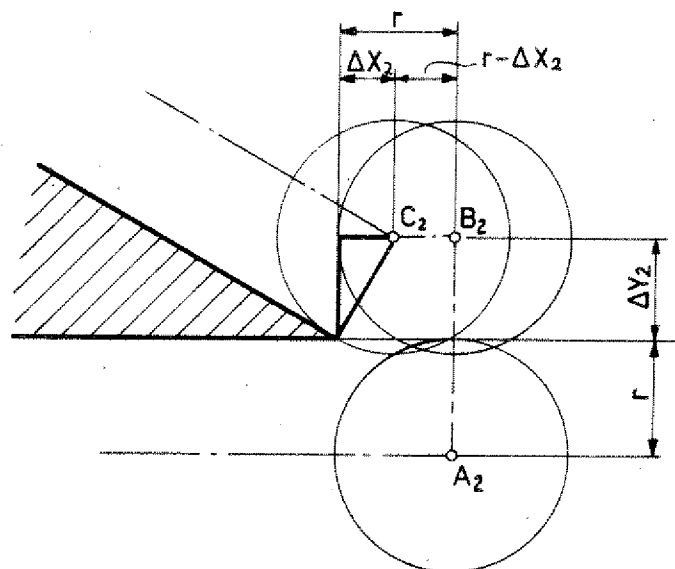
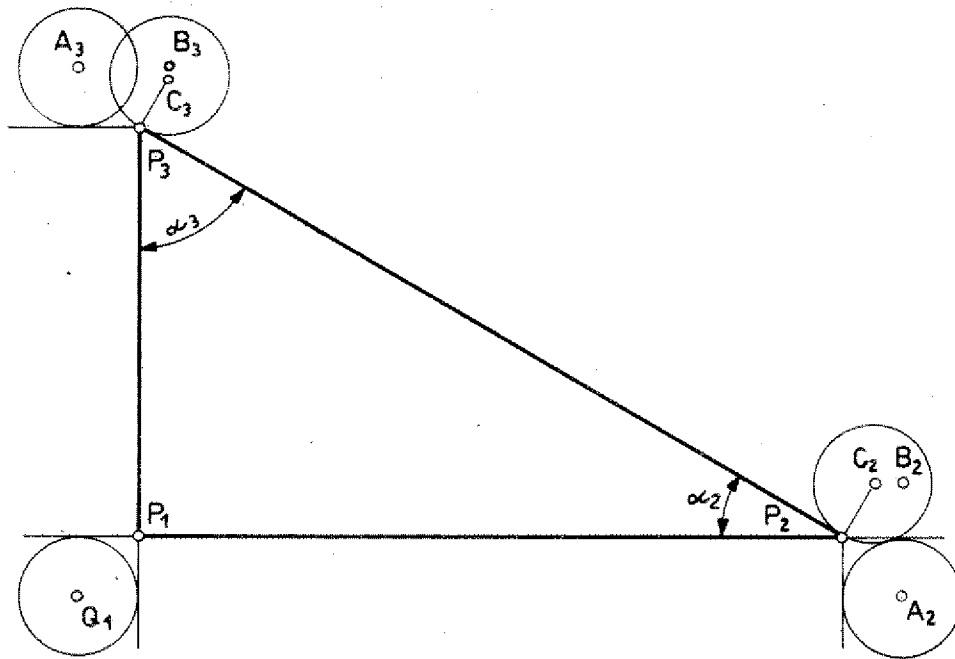

Traverse with various straight lines

Exercise:

- Dimension absolute and incremental,

- Program the paths.

$$P_1 P_2 = 40 \text{ mm}$$

$$\alpha_2 = 30^\circ$$

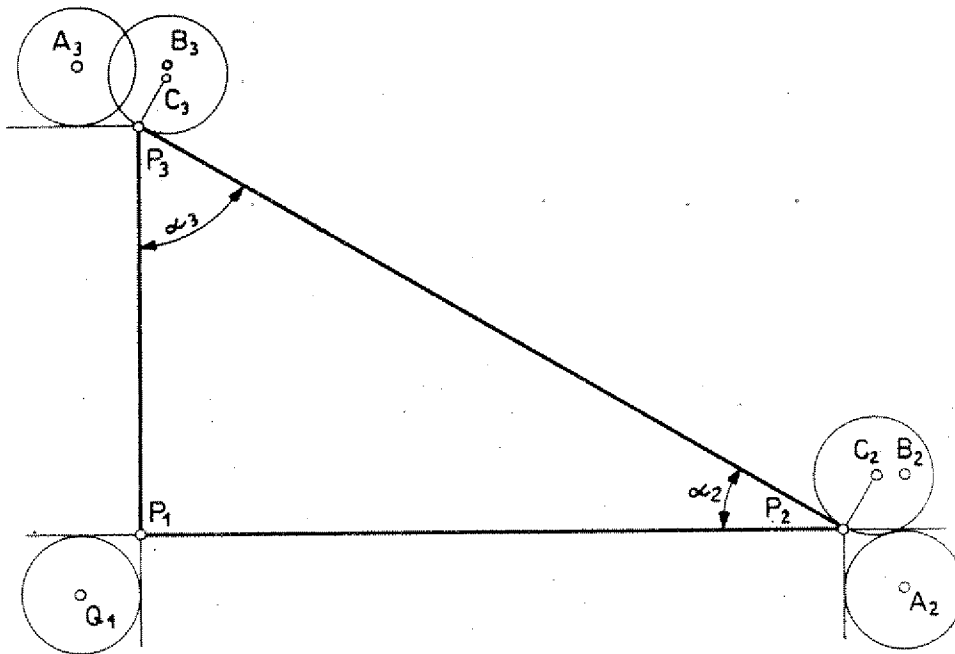
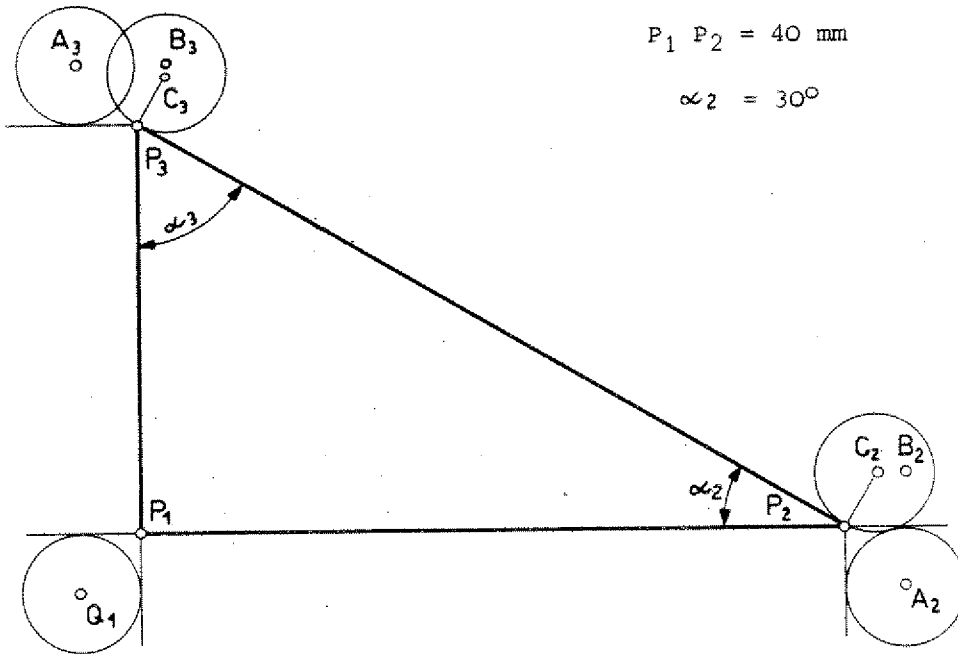

Chapter 5

Programming

The contents are arranged according to the numbering of the G-functions

G90/G91/G92

Compare chapter 4

G65/G66

Compare tape operation

RS-232 C operation

Chapter 10

Hints for the Beginner

- **Program start point**
Program target point
Tool change point
- **Potting the cutter path**

The Start Point of the Program The Tool Change Point The End Point of the Program

Just imagine the sequence of operation: the workpiece has to be mounted and dismounted; tools will have to be changed.

The start point of the program should be chosen so that all handling can be done without any obstacle.

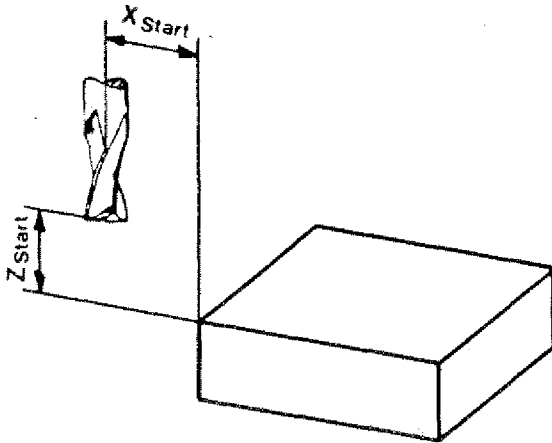

The start point of the program for the tool shall always be the end point of the program.

The tool change point shall be the start point of program for reason of simplicity.

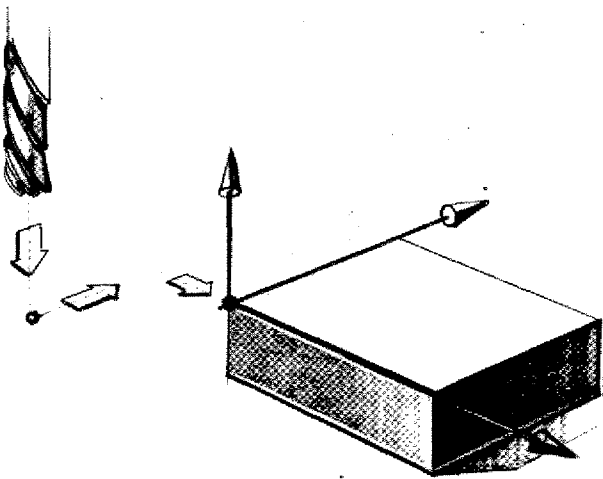

Determination of Coordinates

Scratch or touch the reference surfaces slightly and move the tool by hand to the selected starting point.

Start Point for Chip Removal

Position the tool in a safety distance to the workpiece. So you can find out during a program run whether the tool runs into the workpiece because of a programming fault (with rapid traverse).

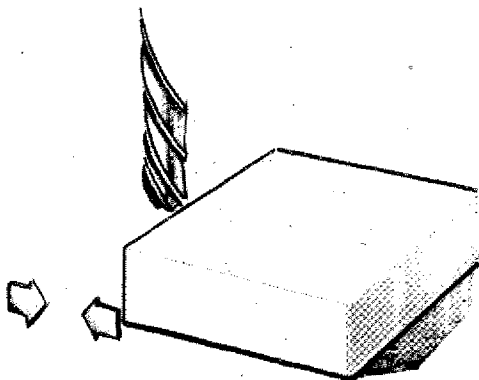

Safety approx. 2 mm

Auxiliary Drawings for Programming

As with the programming of turned pieces also with the programming of milled pieces the technical drawing is a valuable help. This is particularly true in the beginning. It is easier to set up and check the program.

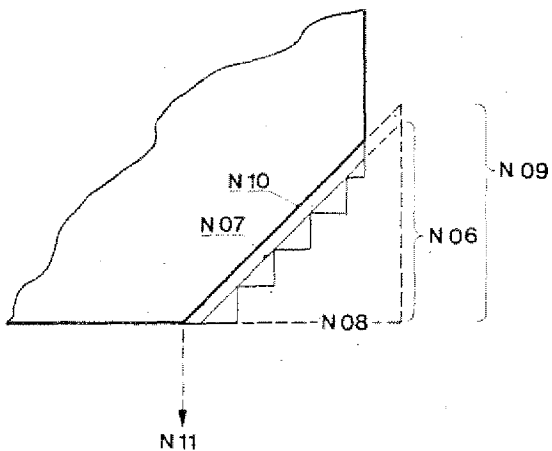

Turned pieces:

You draw and program the path of the edge tip of the tool bit. The edge tip is the part of the tool bit which produces the contour.

The tool bit movement is in one plane, thus it is easier to depict.

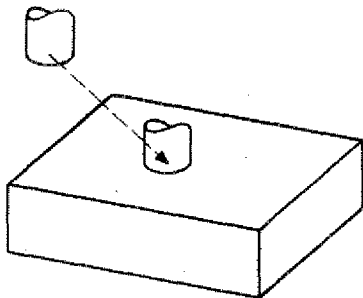

Milled pieces:

Here you have to think and to draw in three dimensions. This needs quite some experience.

A three-dimensional depiction is very distinct but not easy to do. Besides that, all paths which are not parallel to axis show shortened.

A separate drawing is a great help for the first exercises.

An example:

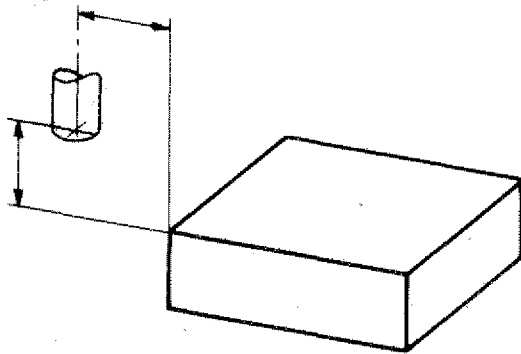

1. Enter into a sketch the program start point of the cutter.

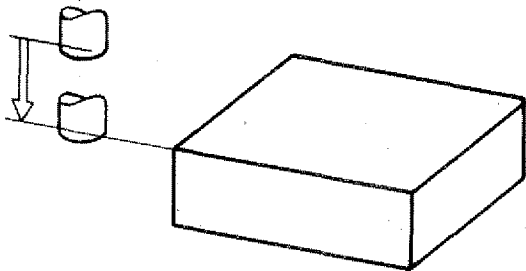

2. If you firstly move in Z-direction to the milling plane you can draw in the workpiece and the cutter path.

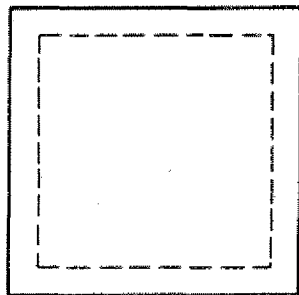

- 2.1. Mark the raw stock contour and the finished part contour.

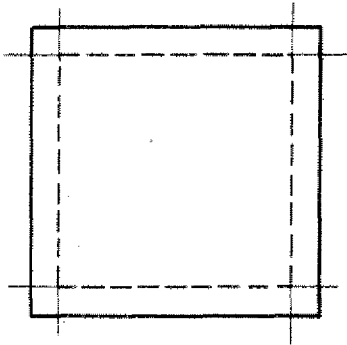

2.2. Draw in the cutter paths. Mark the various auxiliary points.

Draw in the direction of movement.

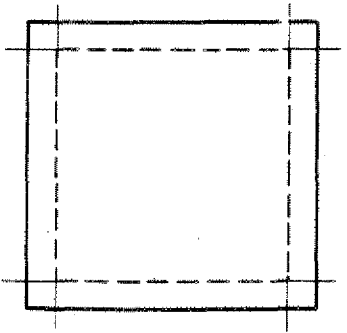

2.3. Number the various blocks. The checking of the program will be much easier.

3. Blocks with no traverse movements programmed can be assigned to the auxiliary points.

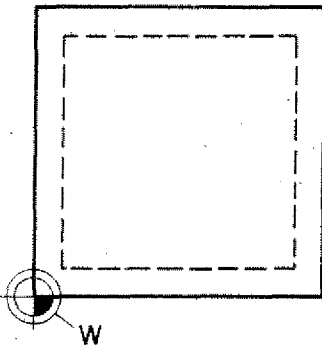

4. With absolute programming draw in zero-point of workpiece.

G00 – Rapid Traverse

Straight line approach movement

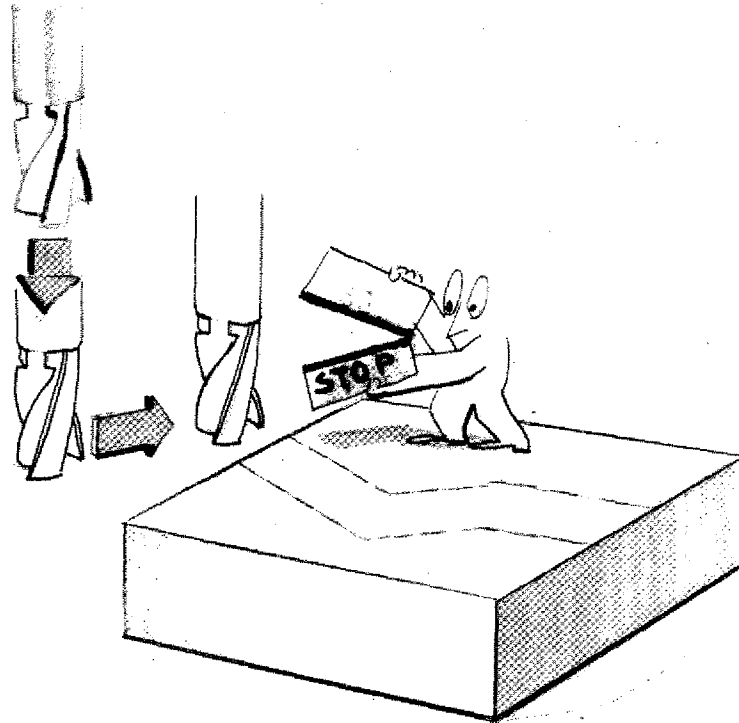

Incremental programming

Absolute programming

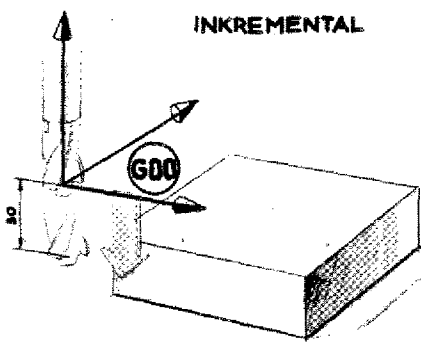

G00 x=0 y=0 z=-3000

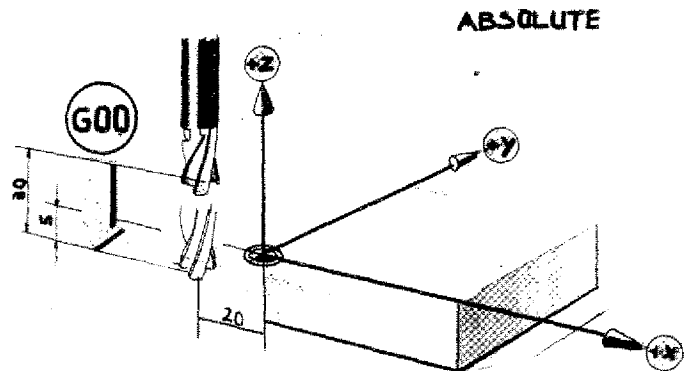

G00 / x-2000 / y=0 / z -500

The target point is described from the starting point of the cutter.

The target point is described from the previously fixed zero-point of the coordinates system.

G00 – Rapid Traverse

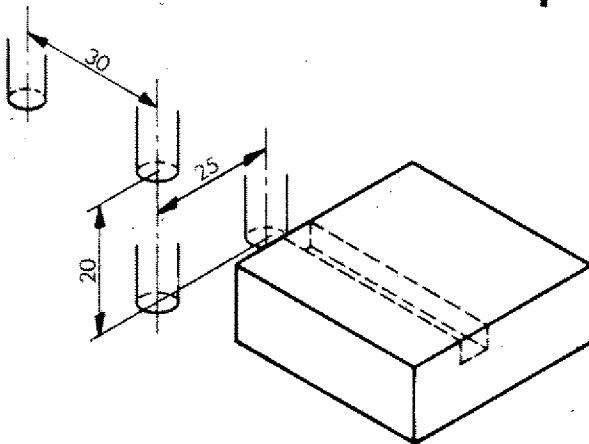

- All movements are carried out with the highest possible speed, i.e. rapid traverse (with the F1-CNC: 600 mm/min).
- G00 is no chip removal movement but a movement without milling cutter being in action.



Format G00
 $N3/G00/X \pm 5/Y \pm 4/Z \pm 5$

N	G (M)	X (J) (D)	Y (K) (S)	Z	F (L) (T) (H)
00	00	3 000	0	0	
01	00	0	0	-2 000	
02	00	0	2 500	0	
03					

- No programming of feed (F) because the slide moves with rapid traverse when G00 is programmed.

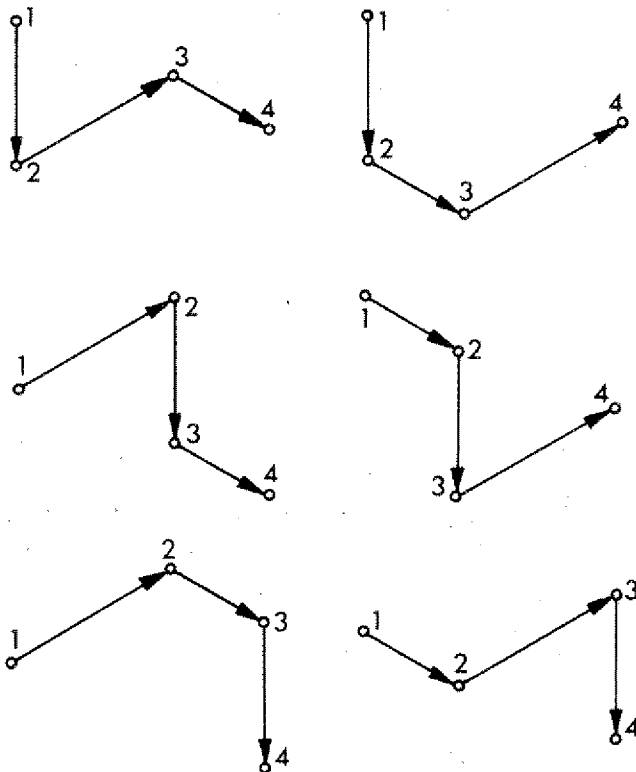

Programming Exercises

In order to move the milling cutter to its working position you have various possibilities.

1. Traverse only in 1 axis

The two other axes are zero. - You have six possibilities. Program all of them, absolute and incremental.

a) Incremental Value Programming:

- The milling cutter is in the position which is indicated in the drawing.
- It is moved to milling position with G00.

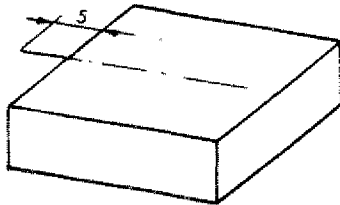

N	G (M)	X (J) (D)	Y (K) (S)	Z	F (L) (T) (H)

b) Absolute Value Programming:

- Milling cutter is moved to milling position.
- Program the traverse paths

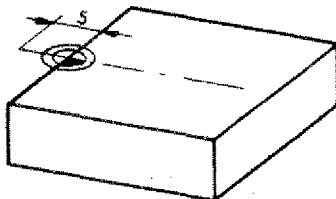

N	G (M)	X (J) (D)	Y (K) (S)	Z	F (L) (T) (H)

2. Traverse in one block simultaneously in 2 axes

Program absolute and incremental. - The zero-point of the coordinate system for the absolute programming is in point P_0 .

Draw in the possibilities.

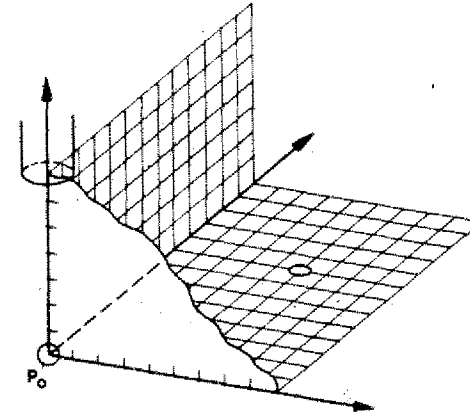
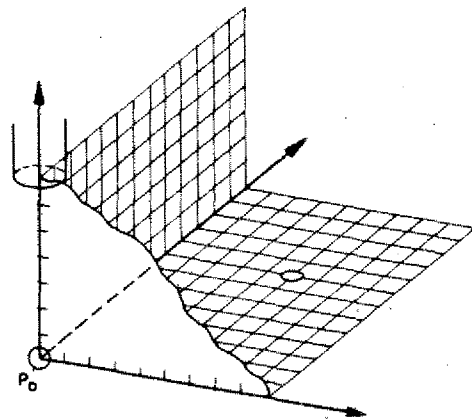
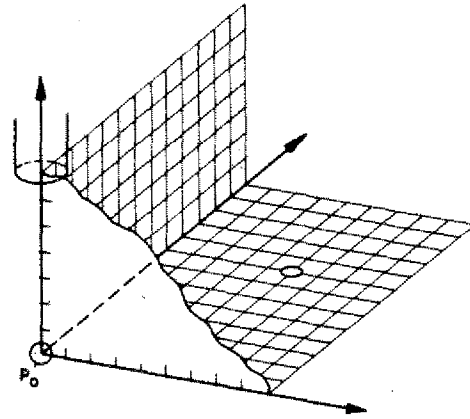
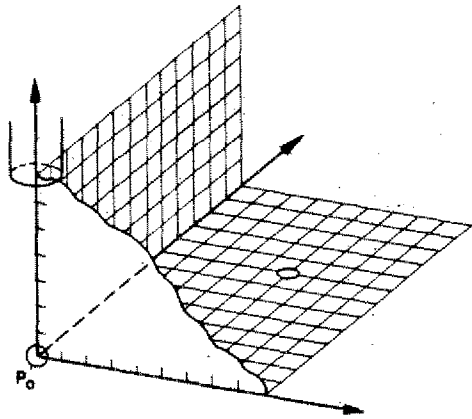
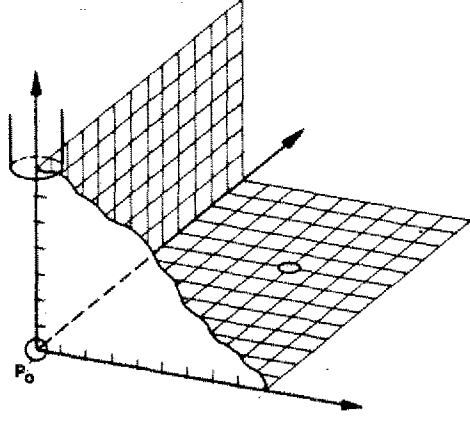
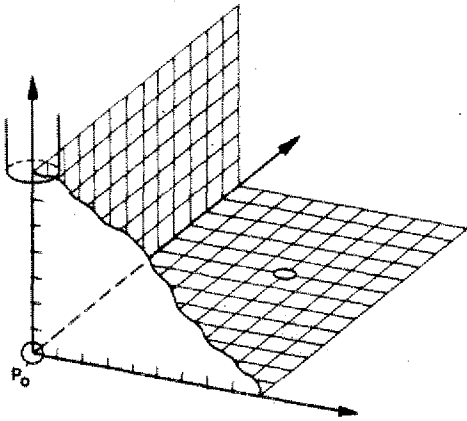

Question:

How many possibilities are given if you move all three axes simultaneously?

G01 – Straight Line Interpolation

Straight line cutting movement, feed programming necessary.

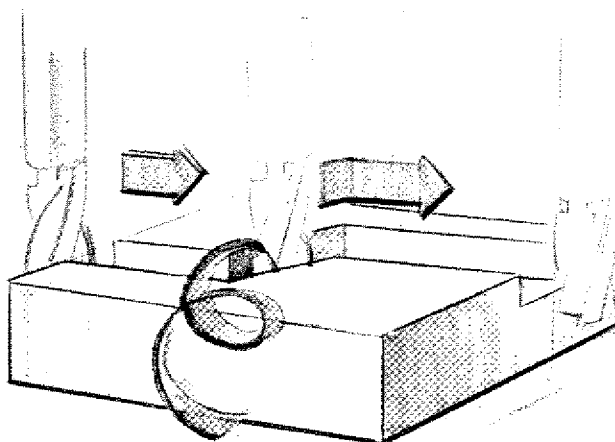

Incremental programming

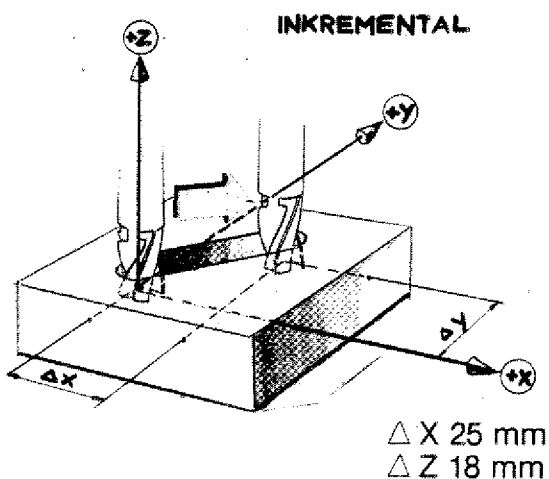

G01/X2500/Y1800/Z = 0/F ...

The target point is described from the starting point of the cutter.

Absolute programming

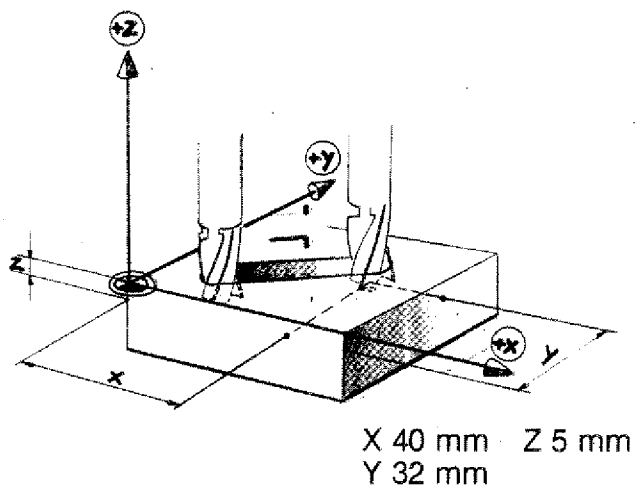

G01/X4000/Y3200/Z -500/F...

The target point is described from the previously fixed zero-point of the coordinates system.

G01 – Linear Interpolation

Linear means straight lined. Interpolation means the finding of intermediate values.

- G01 is a chip removal movement.
- With each chip removal movement you have to program a feed.

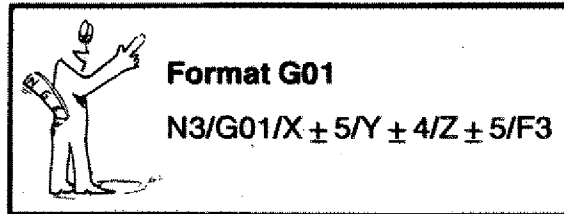

With G01 you can traverse parallel to axis and at each angle in one plane.

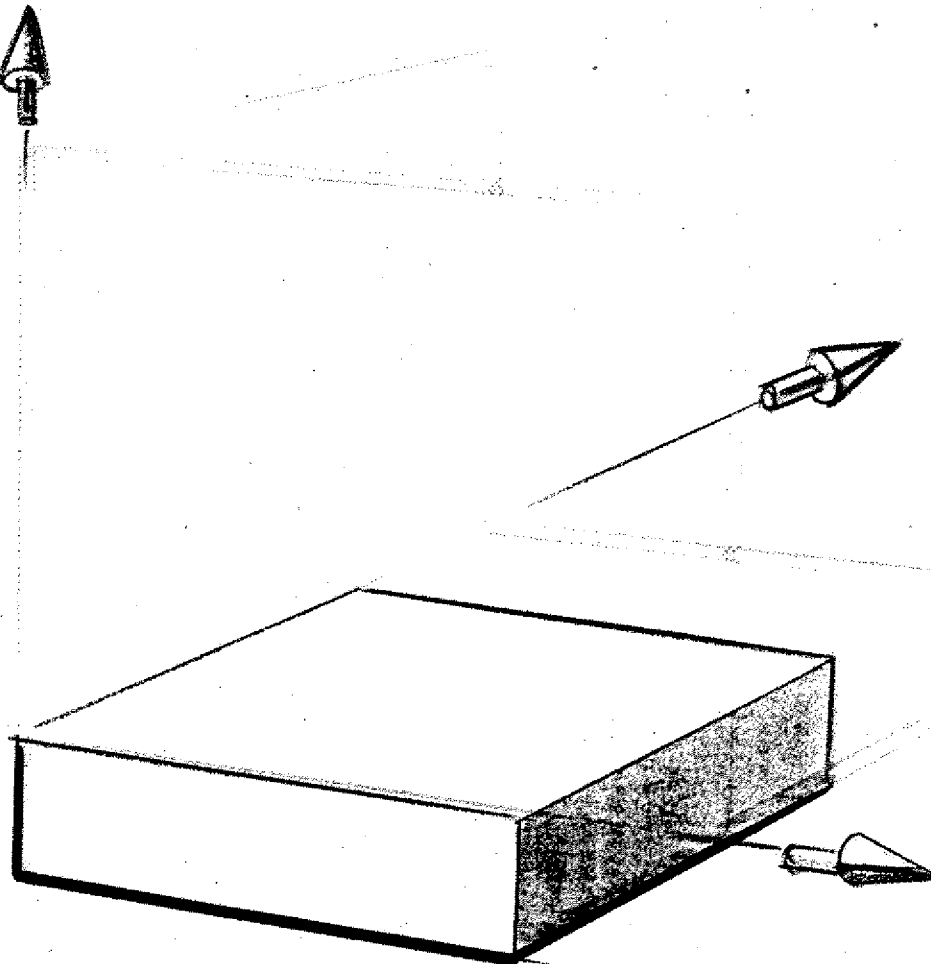

Examples G01 (1)

Milling of a Shoulder

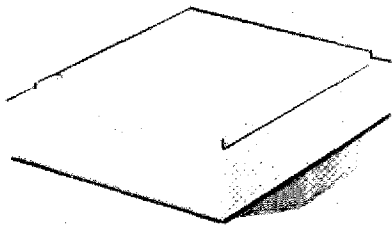

- Milling cutter dia. 10 mm
- Mode of programming: incremental
- A shoulder with a width of 5 mm and a depth of 4 mm has to be milled.

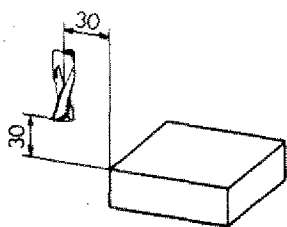
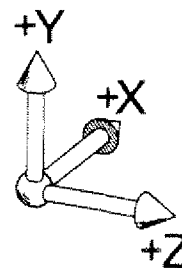
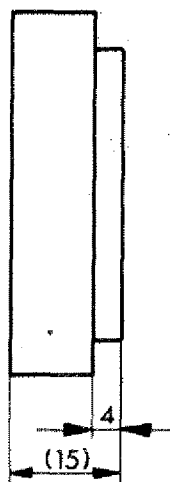
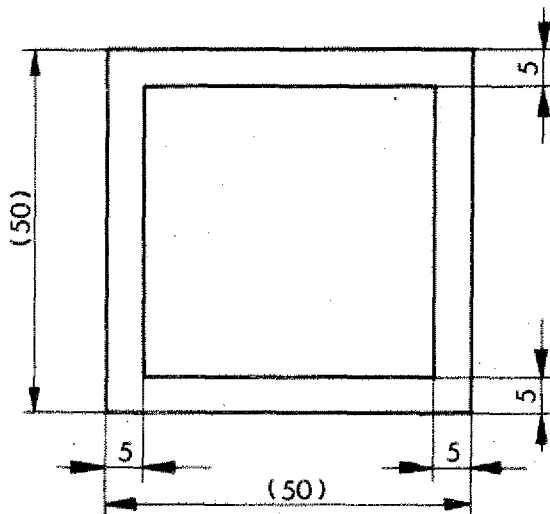

1. Determining the starting point as indicated.

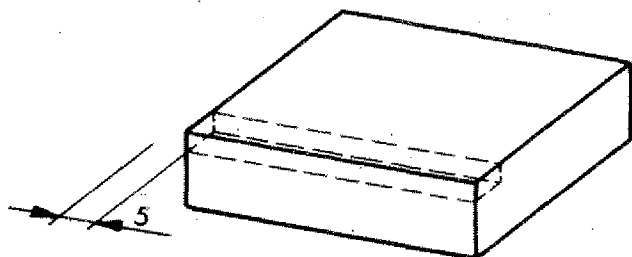

2. Programming with G00 to the starting point of chip removal. Choose a safety distance of 5 mm.

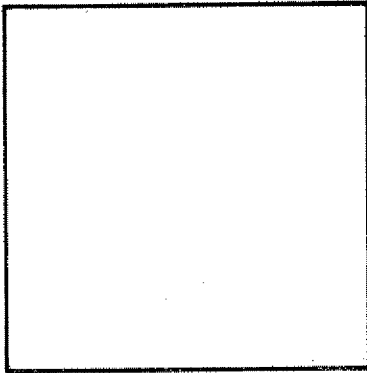
**Example (1)** (continued)**Determination of the Path for the Milling Cutter**

With a diameter of the milling cutter of 10 mm and a width of the shoulder of 5 mm, the axis of the cutter is exactly at the edge of the workpiece.

Programming:

Program end position is starting position.

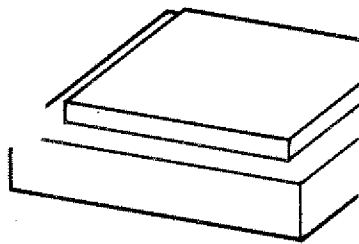

N	G (M)	X (J) (D)	Y (K) (S)	Z	F (L) (T) (H)
00	00	2000	0	0	
01	00	0	0	-3400	
02	01	6000	0	0	200
03	01	0	5000	0	200
04	01	-5000	0	0	200
05	01	0	-5000	0	200
06	00	-3000	0	0	
07	00	0	0	3400	
08	M30				

Exercise 2 for Example 1

- Program this example in absolute values.
- Carry out a zero-point offset with G92.
- Starting position and zero-point of workpiece as in drawing.

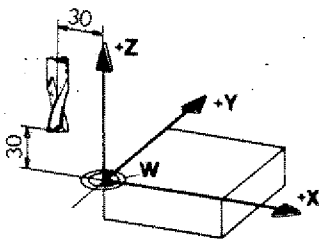

G01 – Example 2

Milling a Groove

- Mode of programming: incremental
- Dia. of milling cutter: 10 mm
- Starting position as in drawing
- Depth of groove: 4 mm
- Feed (compare technological data)
- Safety distance before cutting: 5 mm

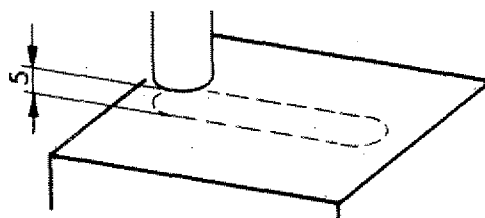
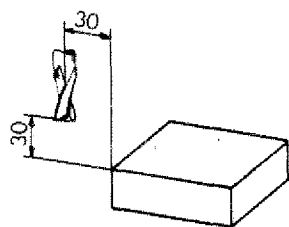

Pay attention:

When feeding in the cutter, halve the feed values.

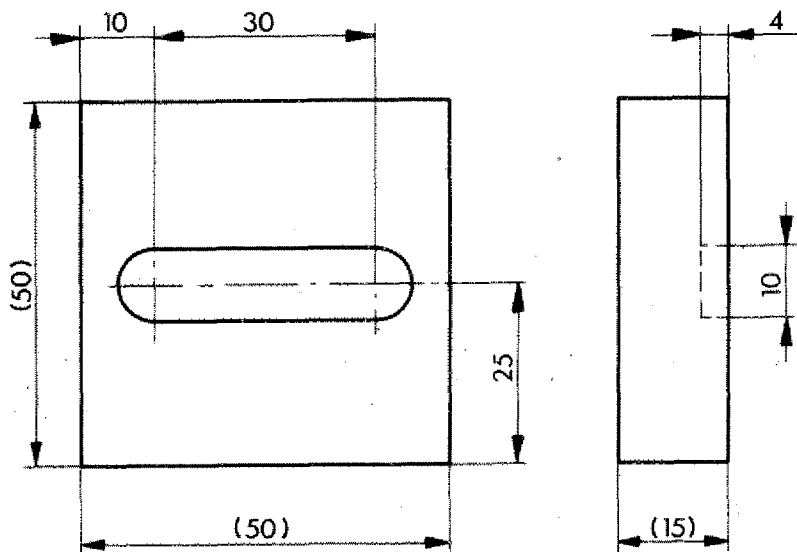

G01 – Example 3
Milling a Pocket

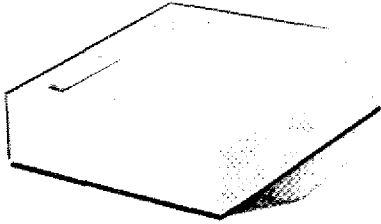

- Milling cutter dia. 10 mm.
- Starting position as in drawing
- Safety distance before cutting 5 mm

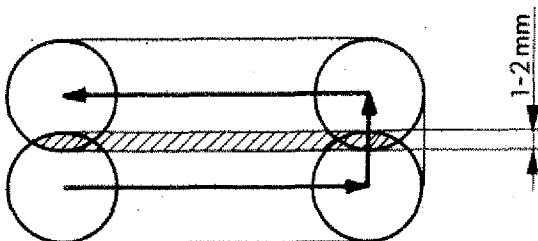
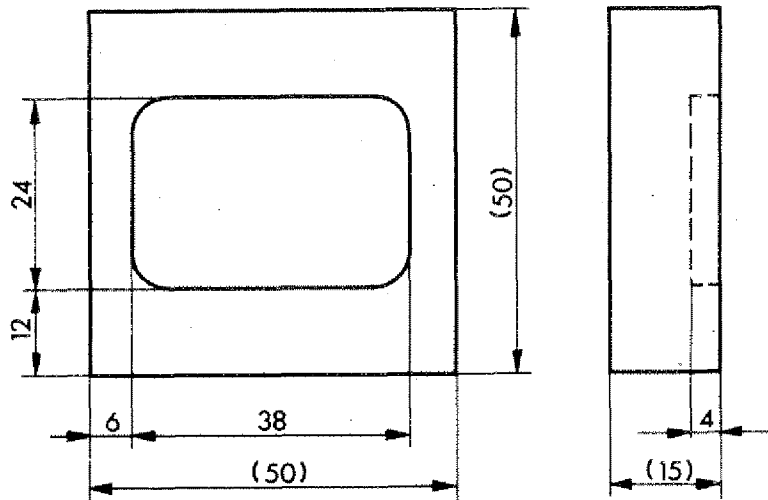

Choose the path of the milling cutter such that there is always an overlap of 1-2 mm (in industry approx. 1/10 of the dia. of the cutter is chosen).

Example 4

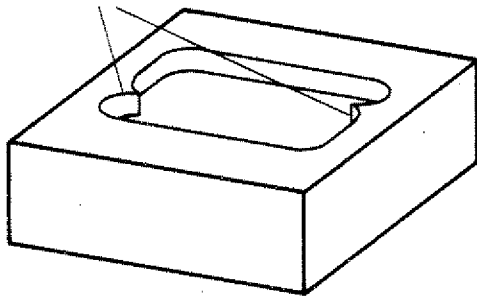

The milling path in example 3 would leave the corners in the pocket unfinished.

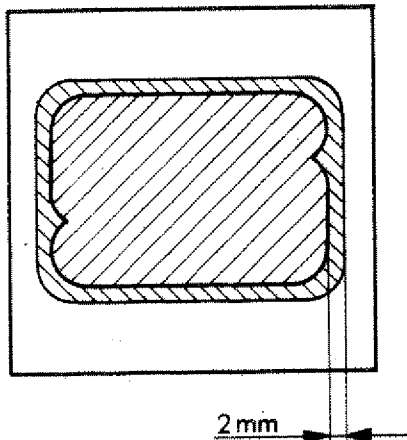

With pocket milling you cut a rough pocket first. With a final cut you mill the complete contour once again to reach a better surface quality.

Exercise:

- Program and mill the given pocket.
- As final run a continuous smooth cut of 2 mm shall be taken off. Mode of programming as you wish.
- Select the zero point of the work-piece yourself.

Example 5/G01

Milling a Cross Slot of 45°

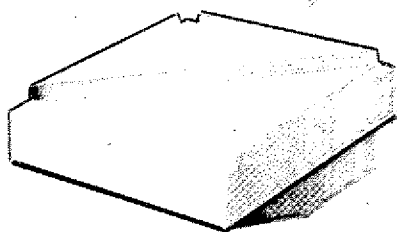

Diameter of milling cutter 8 mm.
Program the zero point of the workpiece using absolute value programming.

Make a drawing and use reference dimensions!

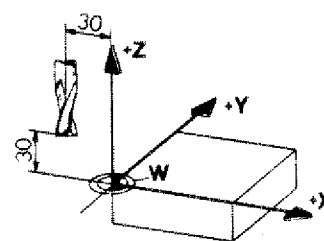
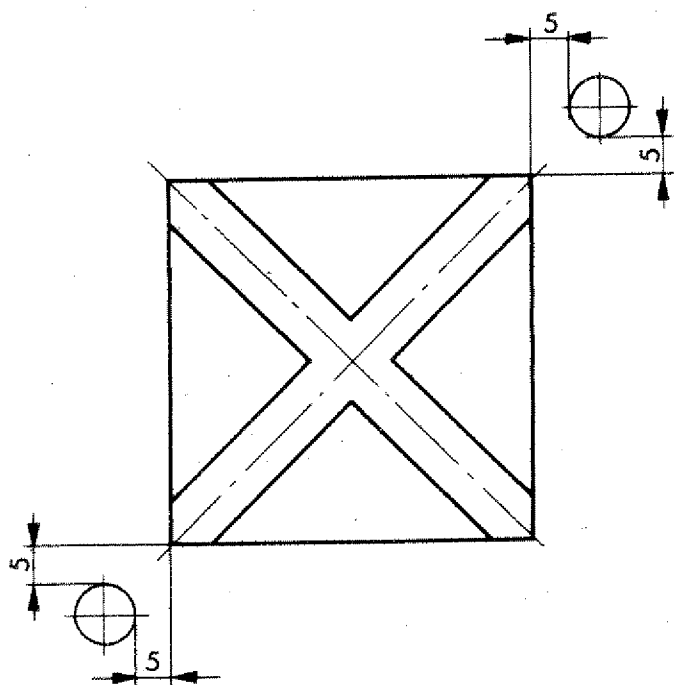
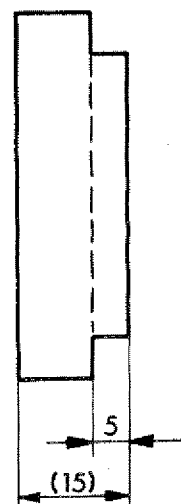
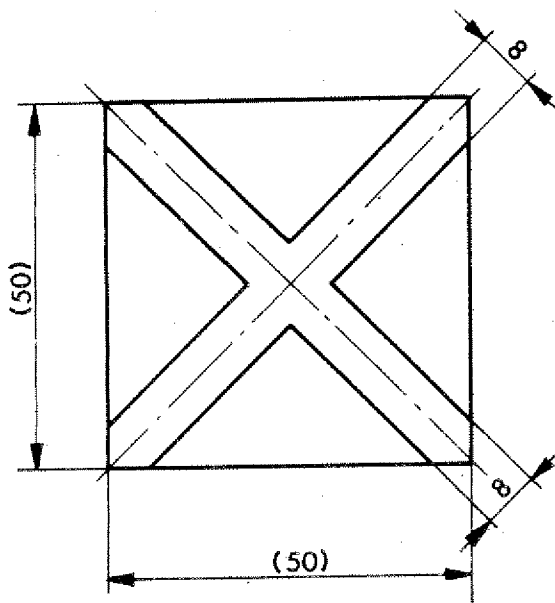

1. Start position: Milling

5 mm away from theoretical X-edge
5 mm away from theoretical Y-edge

2. Target position:

As indicated (X 5 mm, Z 5 mm)

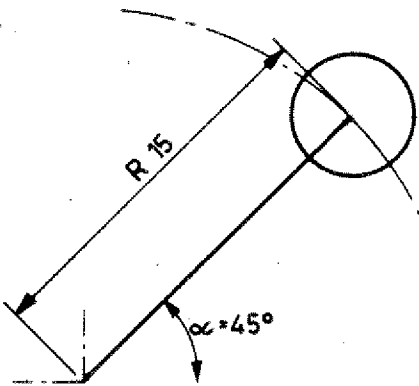
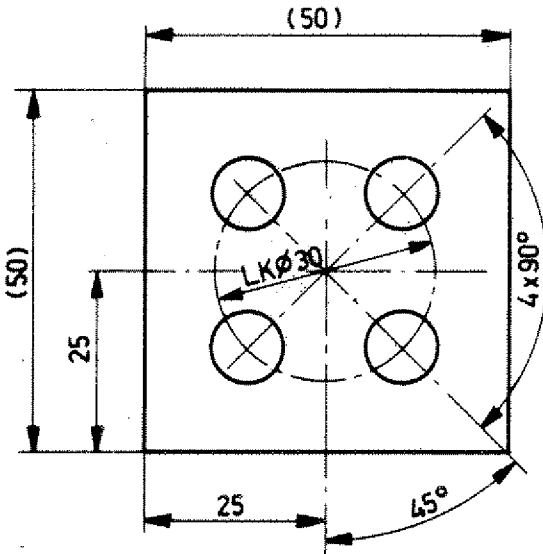

Example 6: Bores 4 x 90°

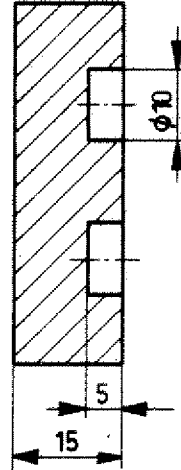

- + The center point coordinates of the bolt circle are known.
- + The coordinates of the bores have to be calculated.

$$\sin \alpha = \frac{Y_1}{R}$$

$$Y_1 = R \cdot \sin 45^\circ = 15,0,707 = 10,6$$

$$\cos \alpha = \frac{X_1}{R}$$

$$X_1 = R \cdot \cos 45^\circ = 15,0,707 = 10,6$$

Since the bores are positioned symmetrically to the center point, you can calculate the X,Y coordinates of the other bores (by adding or subtracting).

Dimension the drawing for CNC-manufacture - in absolute and incremental mode.

Program the example.

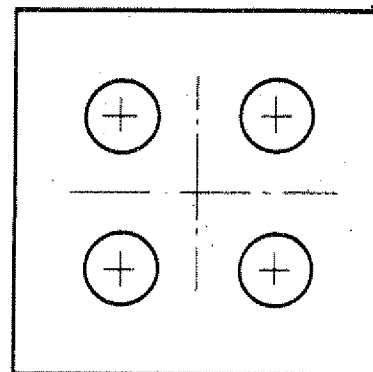
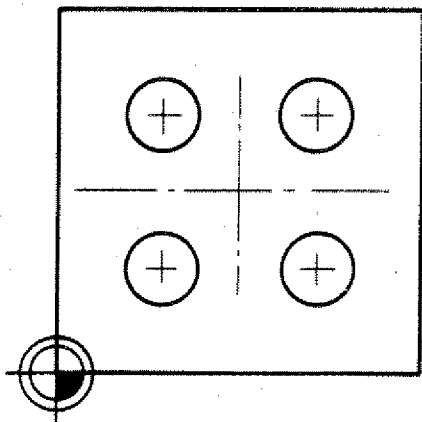

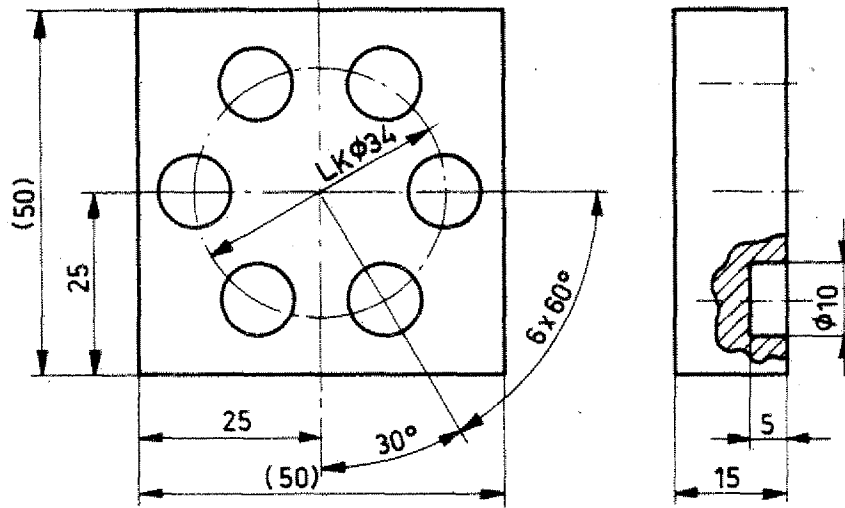

Example 7:
Bores 6 x 60°

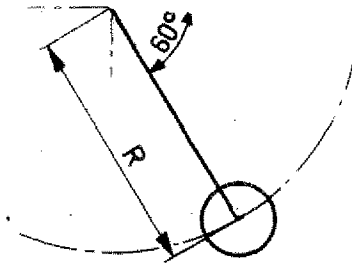

Bolt circle 6 x 60°

- Calculate the coordinates of the bores.
- Dimension the part for CNC programming.
- Program example.

Incremental programming

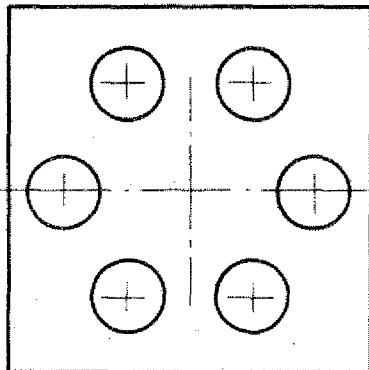

N	G (M)	X (J) (D)	Y (K) (S)	Z	F (L) (T) (H)

Example 8: Hexagon

Use cutter dia. 16 mm

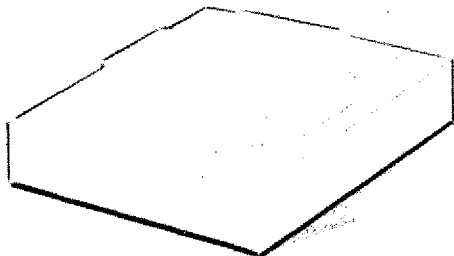

1. You calculated the coordinates of the corner points in one of the previous examples.

Transfer the values for points 1 to 6.

2. You have to calculate the auxiliary coordinates of the cutter center path.

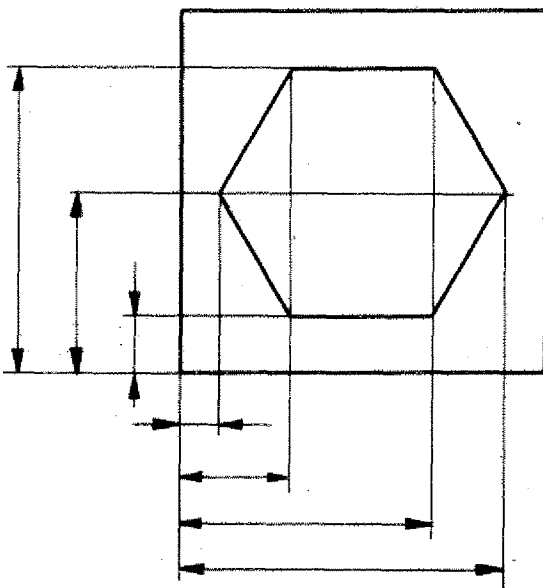
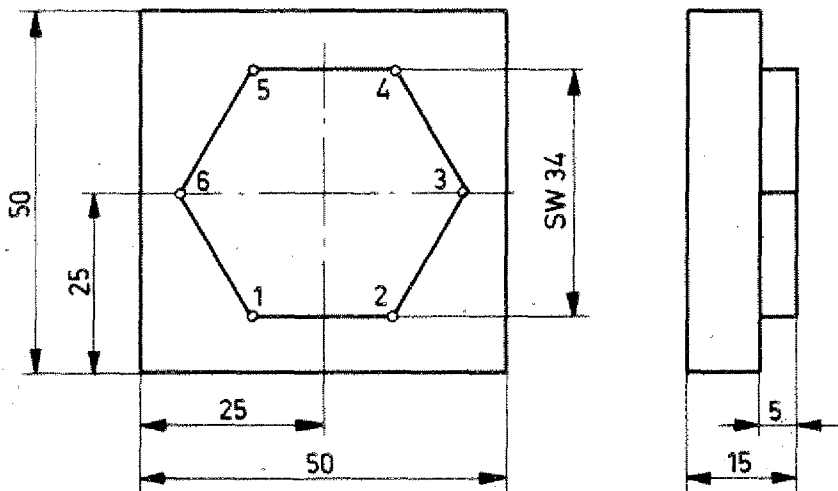

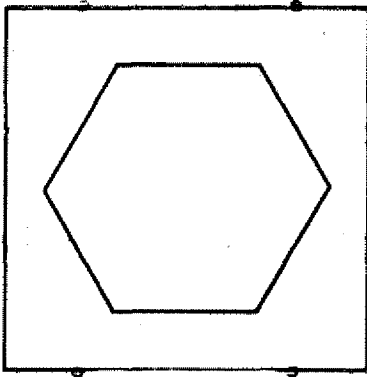
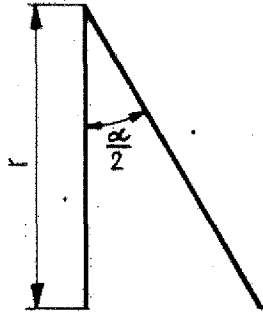
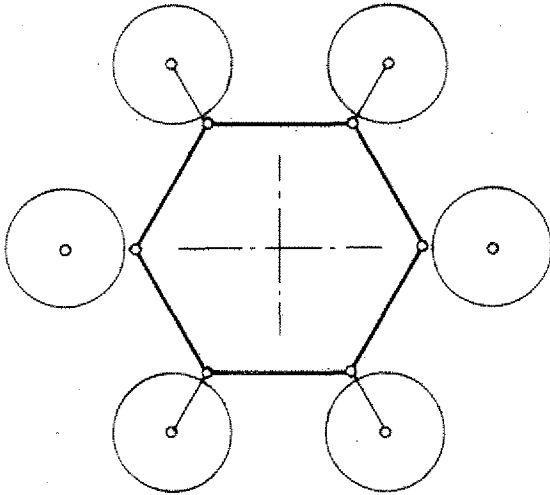
**Example 8:****Hexagon**

You have to add respectively subtract the ΔX and radius values to the coordinate values of points 1,2,3,4,5,6.

Calculation of ΔX

$$\operatorname{tg} \frac{\alpha}{2} = \frac{r}{\Delta X}$$

$$\Delta X = \frac{r}{\operatorname{tg} \frac{\alpha}{2}}$$

Put in measurements for auxiliary points.
program the example!

Pay attention whether there is remaining material at the outer corners. If yes, mill it off.

The Milling of Circular Arcs

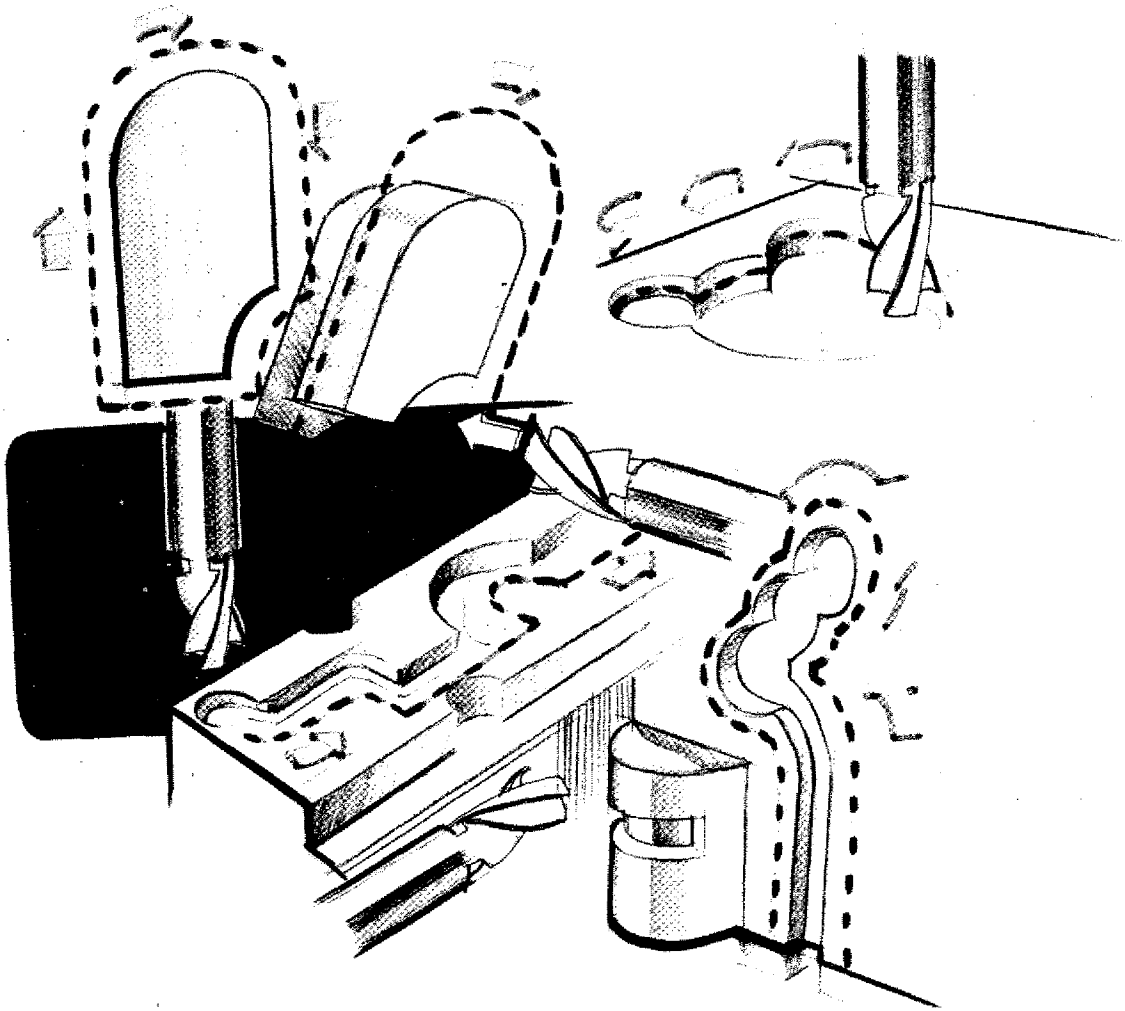

On conventional machine tools circular arcs can be produced only using special auxiliary devices. On CNC-machines circular arcs of any angle or radius can be reached without such special devices. The key information for circular arcs is G02 and G03.

G02 – Circular Interpolation Clockwise

G03 – Circular Interpolation Counterclockwise

In order to formulate what you mean by clockwise and counterclockwise, we have to determine the direction from which we look at.

Determination

You have always to look at the sense of rotation in one plane from the positive direction of the third axis.

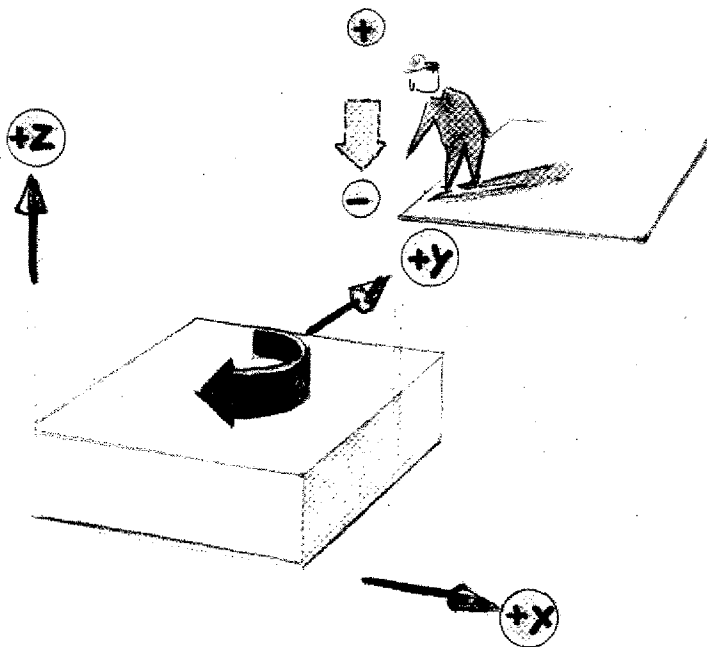

Interpolation Clockwise G02

XY-Plane:

Look from +Z direction
to -Z direction.

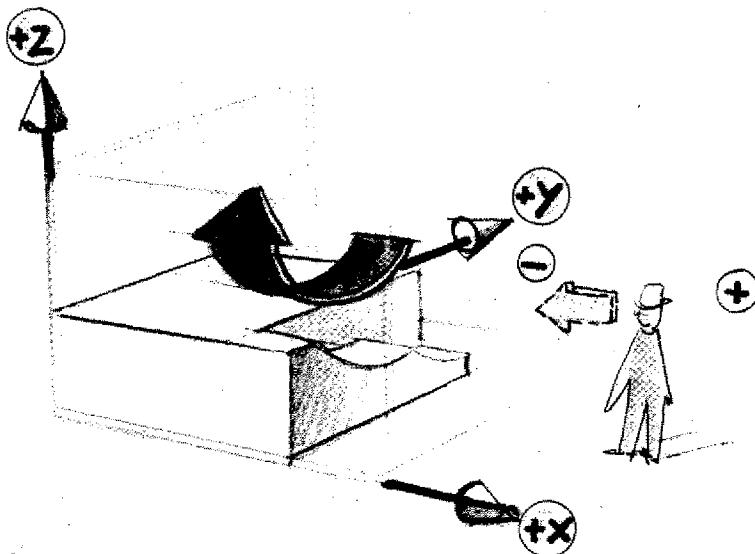

YZ-Plane:

Look from +X to -X.

Interpolation G02 - Clockwise

XZ-Plane:

Look from +Y to -Y.

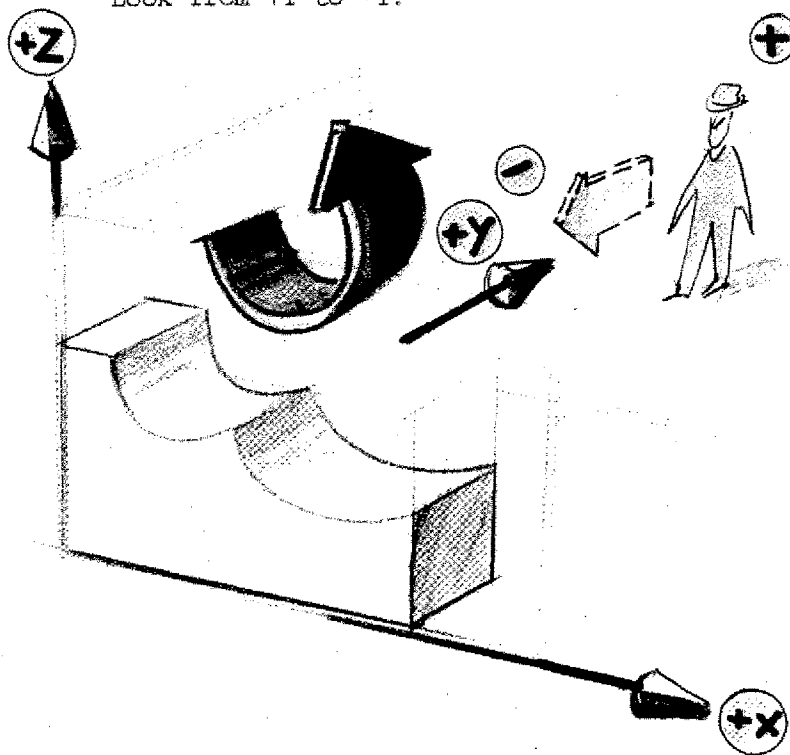

In this technical sketch the direction in the XZ-plane seems to be inverted.

Interpolation G02

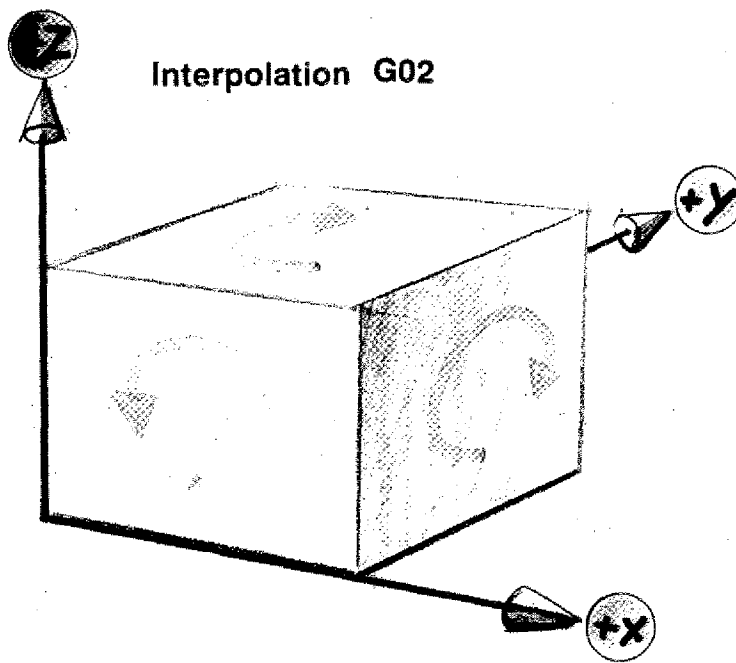

Arcs on the F1-CNC Milling Machine

Metric

Size of radii 0,01 - 99,99 mm
in steps of 0,01 mm

Inch

Size of radii 0,001 - 3.999 Inch in
steps of 1/1000 inch

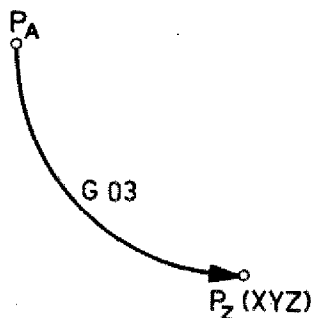
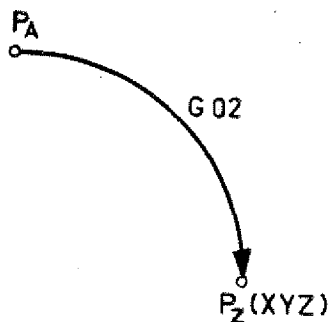

Programming

On the F1-CNC you can program quarter arcs (90°) or arcs of circles in steps of 1° .

Programming of arcs 90° on the F1-CNC

1. The sense of rotation is described with G02/G03.
2. The end point of the quarter arc is determined by the X,Y,Z addresses - either starting from point PA (incremental) or from the workpiece zero-point (absolute).
3. The F-address is used to describe the feed.



Format

$$N3 \left\{ \begin{array}{l} G02 \\ G03 \end{array} \right. X \pm 5 (\pm 4) / Y \pm 4 (\pm 5) / Z \pm 5 / F3$$

± 4 resp. ± 5 with X,Y-values for vertical resp. horizontal axis system.

Programming of Quarter Arcs in the XY-Plane

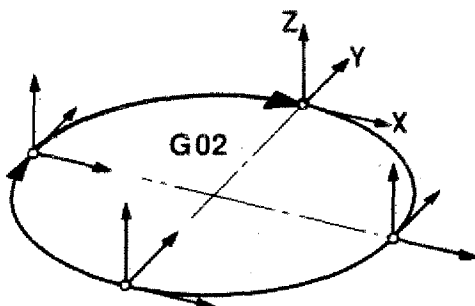
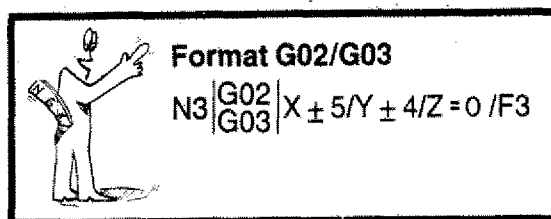

G02 Incremental Programming

Example: radius 10 mm

Programmed are X,Y values looked at from the starting point.

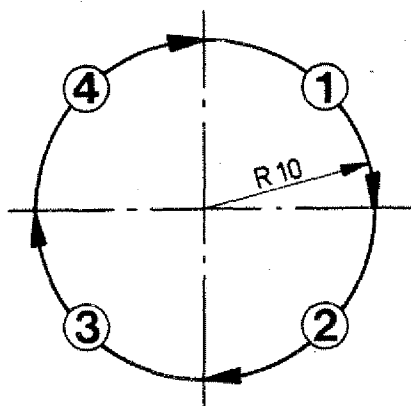

N	G	X	Y	Z	F	
	O2	+1000	-1000	0	...	Arc 1
	O2	-1000	-1000	0		Arc 2
	O2	-1000	+1000	0		Arc 3
	O2	+1000	+1000	0		Arc 4

Attention:

In the XY-plane the Z-value has to be programmed with zero.

G02 - Absolute Programming

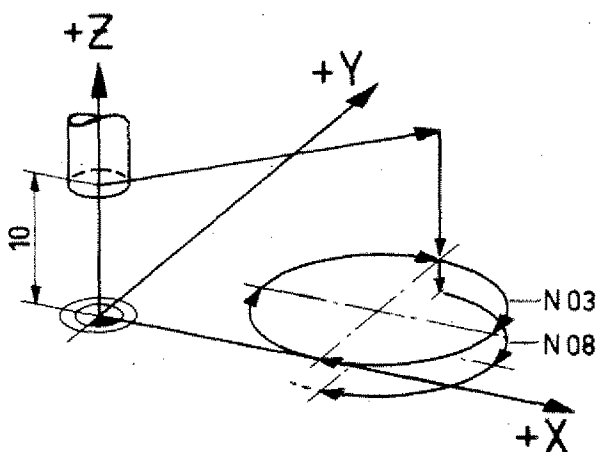

Zero-point of workpiece as indicated in drawing.

You program the XY-coordinates of the end point of quarter arc, looked at from the previously fixed point (W).



Format G02/G03
 $N3 \begin{matrix} G02 \\ G03 \end{matrix} | X \pm 5 / Y \pm 4 / Z \pm 5 / F3$

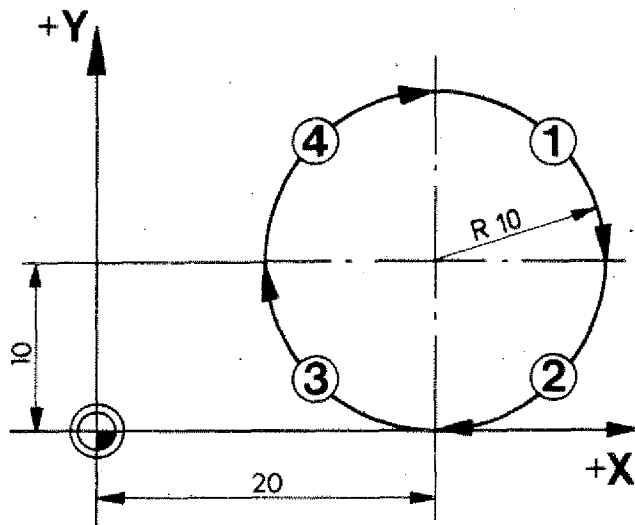

Note:

Arcs can be moved only in one plane. Thus, the Z-value of the previous block has to be taken over.

- Block N01/N02: Move to start position
- Block N7: Infeed in Z -100
- Block N8/N9: Arcs 1,2 set deeper

N	G	X	Y	Z	F	
000	92	0	0	1000		
01	00	2000	2000	1000		
2	01	2000	2000	0	...	Position milling cutter at start G02
3	02	3000	1000	0	...	
4	02	2000	0	0	...	
5	02	1000	1000	0	...	
6	02	2000	2000	0	...	
7	01	2000	2000	-100	...	Position milling cutter at start G02
8	02	3000	1000	-100	...	
9	02	2000	0	-100	...	
10	⋮	⋮	⋮	⋮	⋮	

Exercises

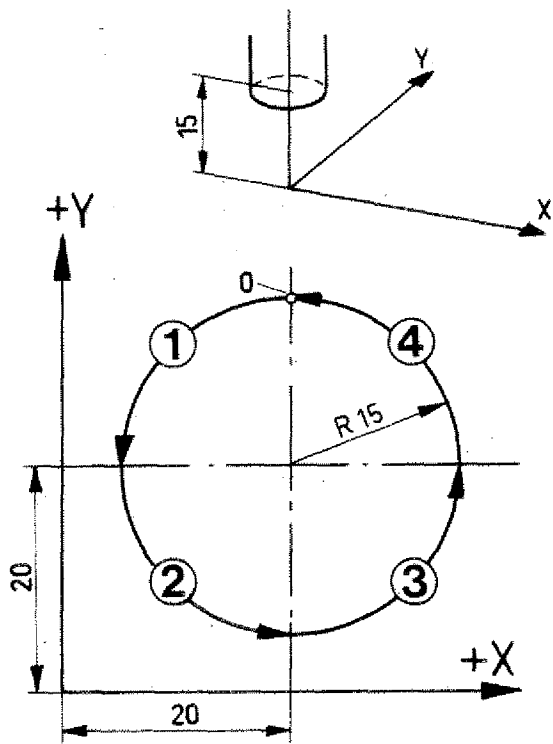

G03 – Incremental Programming

- Position of milling cutter at start as indicated in drawing.
- Circle is in XY-plane
Z=0
- Start the circle programming in point "0".

N	G (M)	X (J) (D)	Y (K) (S)	Z	F (L)(T)(H)

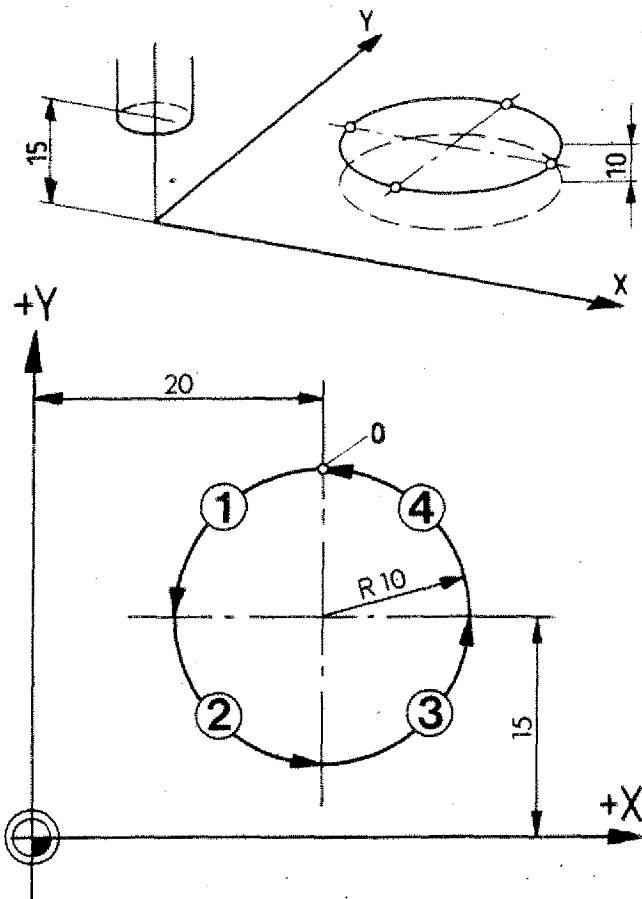

G03 – Absolute Programming

- Position of milling cutter at start as indicated in drawing.
- Carry out offset of zero point.
- Circle is parallel in XY-plane, but at a distance Z +10 mm.
- Start the circle programming in point "0".

N	G (M)	X (J) (D)	Y (K) (S)	Z	F (L)(T)(H)

Programming Exercise G02/G03

- Mode of Programming: incremental
- Approach direction as in drawing
- Determine starting point yourself
- Determine drawing with dimensioning of triangulation (station).

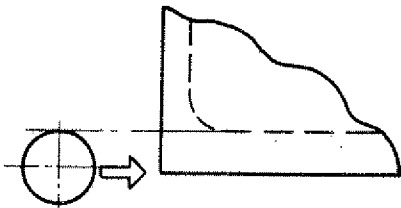
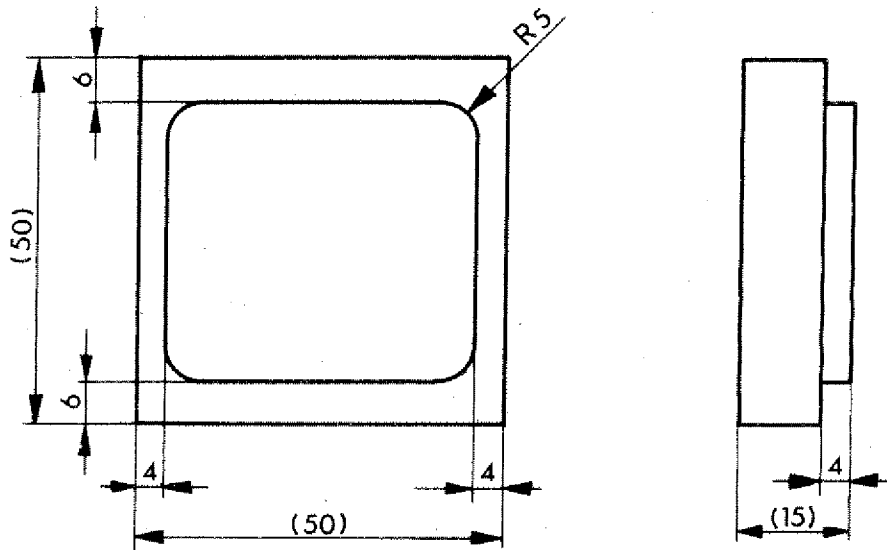

Approach direction as in drawing.

Programming Exercise G02/G03

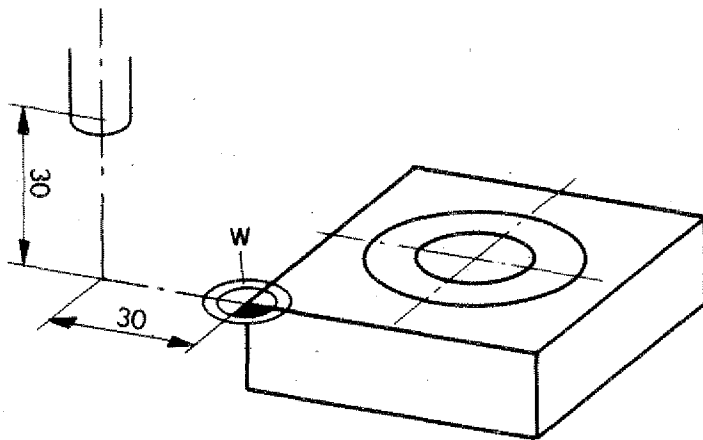
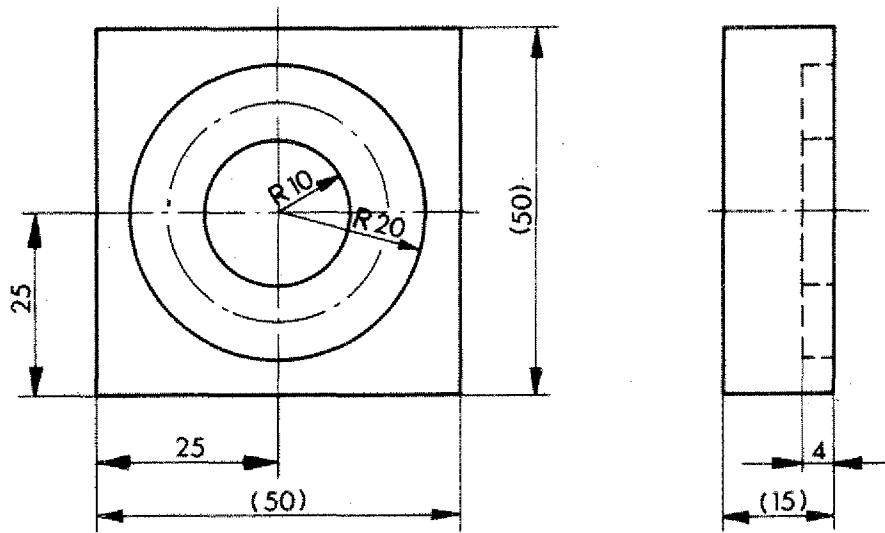

Alternative 1

- Mode of Programming: absolute
- Zero-point of workpiece as in drawing.
- Starting point of milling cutter as in drawing.
- Dia. of milling cutter 10 mm.

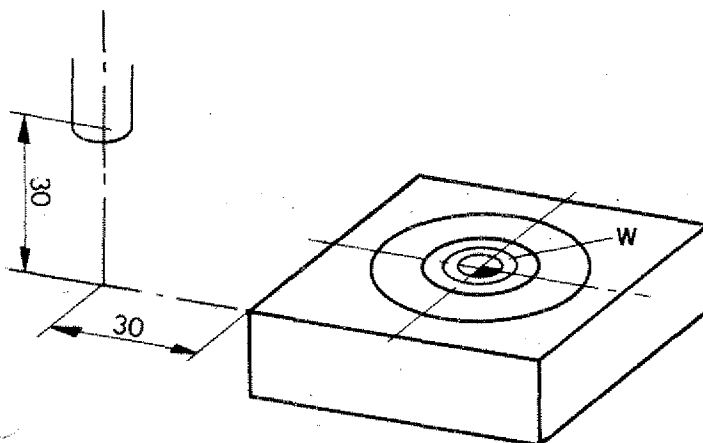

Alternative 2

- Mode of programming: absolute
- Zero-point of workpiece as in drawing
- Starting point as in drawing.

Circles X-Z Plane

Exercise

- Mode of programming: incremental
- Starting point as in drawing

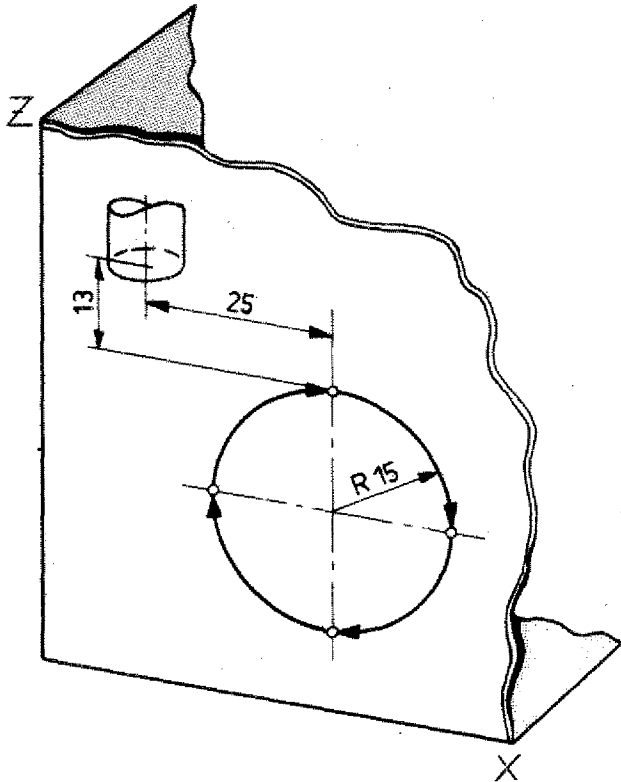

N	G (M)	X (J) (D)	Y (K) (S)	Z	F (L)(T)(H)

Exercise

- Mode of programming: absolute
- Zero-point as in drawing
- Starting point and end point for programming is the zero-point.

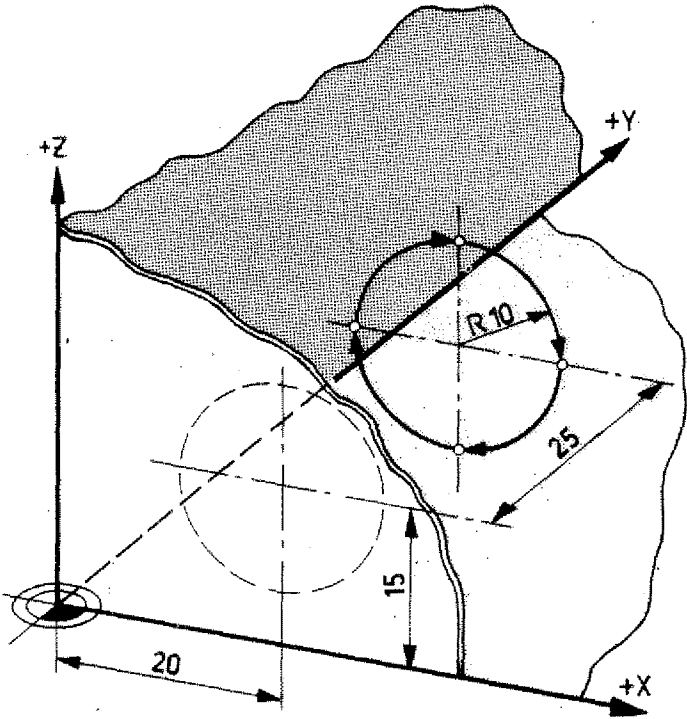

N	G (M)	X (J) (D)	Y (K) (S)	Z	F (L)(T)(H)

Some Terms for Circular Interpolation G02/03

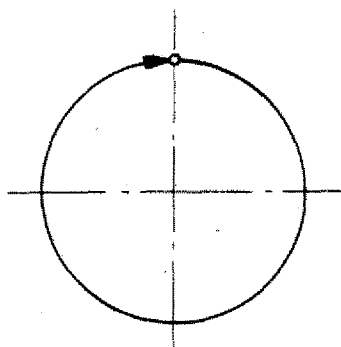

Complete circle programming

A circle up to 360° can be programmed in one block.

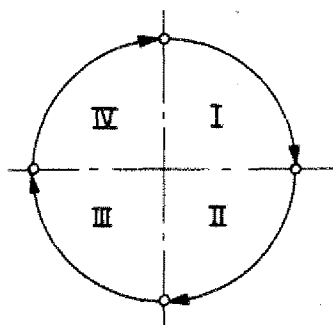

Quadrants programming

A circle is divided into 4 quadrants. In one block only one arc of max. 90° can be programmed. The arc of circle has to be within a given quadrant.

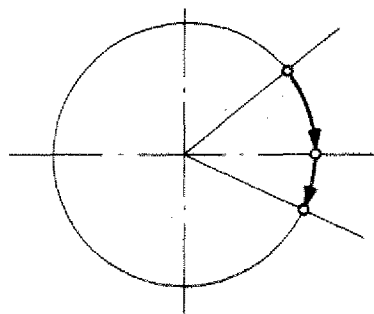

In this case two blocks are necessary because the arc reaches over 2 quadrants.

F1-CNC

- Quadrants programming
- To program a part of an arc within a quadrant, a code in two blocks is used.

Arcs with Angles at Random

On the F1-CNC arcs in steps of 1° each can be programmed. The programming is done in various subsequent blocks.

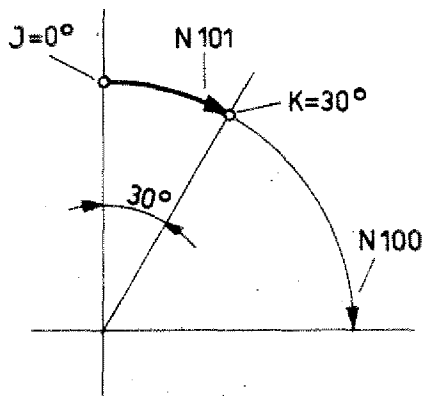

Blocks N100/101 are considered by the computer to be one unit. The computer asks whether there is a M99 instruction in the block following a G02/G03 instruction.

Mode of programming: incremental

(The following examples are in the XY-plane; for all other planes this principle is valid too).

Radius 10 mm

First block

Here the 90° arc in which the partial arc circle is situated will be determined.

N100/G02/X1000/Y-1000/Z.../F..

With G02 the computer is given information on the sense of rotation.

With X 1000/Y -1000 the computer knows the quadrant (\pm sign of X,Y) and the radius of the arc.

Next block

N101/M99/J = 0/K = 30

M99 is the key information for the arc $\neq 90^\circ$.

J-address: for the grades statement of the start of the arc within the quadrant.

K-address: target address of the arc. Statement in grades.

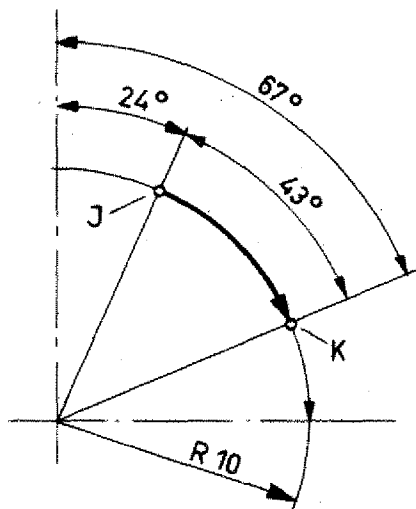

Example
Incremental value programming

N100/G02/X1000/Y -1000/Z=0/F...
 N101/M99/J24/K67

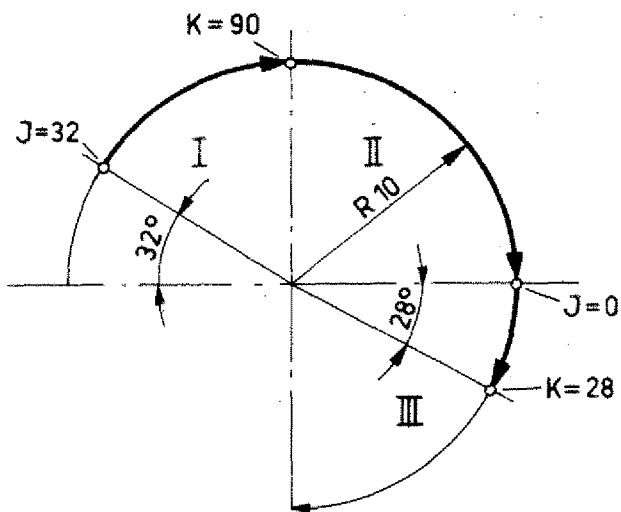

Example
Incremental value programming

Arc of circle reaching over a few quadrants.

N100/G02/X1000/Y1000/Z=0/F...
 N101/M99/J32/K90
 Arc in quadrant I.

N102/G02/X1000/Y -1000/Z=0/F...
 Arc in quadrant II.

N103/G02/X -1000/Y -1000/Z=0/F...
 N104/M99/J=0/K28
 Arc in quadrant III.

Using the Chart

The chart shows you the J,K-values, the exact grades and the coordinates of points for a circle with radius 1.

In order to program the cutter path it is often necessary to calculate the coordinates of the arc starting (PA) and target point (PZ). These points are missing in many drawings.

(All examples are in the X,Y-plane, the same principle is valid for all other planes too)

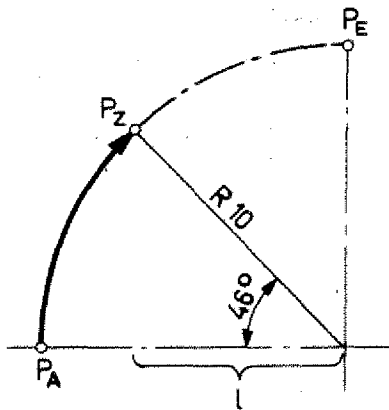

Example:

X(a) and Y(b) coordinates of the target point (PZ) are not known.

Calculation: a

$$a = R \cdot \cos 46.01 = \frac{1}{R}$$

$$l = R \cdot \cos 46.01 = 6.9453$$
$$a = 10 - 6.945 = 3.0567$$

Calculation: b

$$\sin 46.01 = \frac{b}{R}$$

$$b = R \cdot \sin 46.01 = 7.194$$

These values can also be read from the chart.

Circular Interpolation – Parameter XYZ-Values at the Circle 1

		a	b
J,K	Grad	XYZ	XYZ
0	0	0	0
1	1.03	0	181
2	1.98	0	347
3	3.02	14	528
4	4.06	28	708
5	5.10	42	889
6	6.05	56	1056
7	7.01	69	1222
8	8.06	97	1403
9	9.03	125	1569
10	9.99	153	1736
11	10.96	181	1903
12	11.93	208	2069
13	12.99	250	2250
14	14.05	292	2431
15	15.03	333	2597
16	16.02	375	2764
17	17.02	431	2931
18	18.03	486	3097
19	19.03	542	3264
20	20.04	597	3431
21	20.97	653	3583
22	22.00	722	3750
23	23.04	792	3917
24	24.00	861	4069
25	24.96	931	4222
26	25.92	1000	4375
27	26.99	1083	4542
28	27.98	1167	4694
29	28.98	1250	4847
30	29.98	1333	5000
31	30.97	1417	5153
32	32.01	1514	5306
33	33.05	1611	5458
34	34.02	1708	5597
35	34.99	1806	5736
36	35.96	1903	5875
37	36.93	2000	6014
38	37.95	2111	6153
39	38.97	2222	6292
40	39.98	2333	6431
41	41.00	2444	6569
42	41.96	2556	6694
43	42.97	2681	6819
44	43.98	2806	6944
45	45.00	2931	7069

		a	b
J,K	Grad	XYZ	XYZ
46	46.01	3056	7194
47	47.02	3181	7319
48	48.03	3306	7444
49	48.99	3431	7556
50	50.01	3569	7667
51	51.02	3708	7778
52	52.04	3847	7889
53	53.06	3986	8000
54	54.03	4125	8097
55	55.00	4264	8194
56	55.97	4403	8292
57	56.94	4542	8389
58	57.98	4694	8486
59	59.02	4847	8583
60	60.01	5000	8667
61	61.01	5153	8750
62	62.01	5306	8833
63	63.00	5458	8917
64	64.07	5625	9000
65	65.03	5778	9069
66	65.99	5931	9139
67	66.95	6083	9208
68	67.99	6250	9278
69	69.02	6417	9347
70	69.95	6569	9403
71	70.96	6736	9458
72	71.96	6903	9514
73	72.97	7069	9569
74	73.97	7236	9625
75	74.96	7403	9667
76	75.94	7569	9708
77	77.00	7750	9750
78	78.06	7931	9792
79	79.03	8097	9819
80	80.00	8264	9847
81	80.96	8431	9875
82	81.93	8597	9903
83	82.98	8778	9931
84	83.94	8944	9944
85	84.89	9111	9958
86	85.93	9292	9972
87	86.97	9472	9986
88	88.01	9653	10000
89	88.96	9819	10000
90	90.00	10000	10000

In the charts the a,b values are indicated for the standard circle in 4 digits.

16	16.02	375	2764
17	17.02	431	2931
18	18.03	486	3097
19	19.03	542	3264
20	20.04	597	3431
21	20.97	653	3589
22	22.00	722	3750
23	23.04	792	3917
24	24.00	861	4069
25	24.96	931	4222
26	25.92	1000	4375
27	26.99	1083	4542
28	27.98	1167	4694
29	28.98	1250	4847
30	29.98	1333	5000

Example Radius 1 mm
25° (24,96°)

a-value: 0,0931 mm

b-value: 0,4222 mm

31	30.97	1417	5153
32	32.01	1514	5306
33	33.05	1611	5458
34	34.02	1708	5597
35	34.99	1806	5736
36	35.96	1903	5875
37	36.93	2000	6014
38	37.95	2111	6153
39	38.97	2222	6292
40	39.98	2333	6431
41	41.00	2444	6569
42	41.96	2556	6694
43	42.97	2681	6819
44	43.98	2806	6944
45	45.00	2931	7069

**Values (a, b) for any
desired angle (random)**

Multiply a,b values with radius sizes

Example

$\alpha = 41^\circ$

Radius 6,35 mm

a = 0,2444 x 6,35 = 1,55194

b = 0,6569 x 6,35 = 4,171315

The values must be programmed without rounding off.

a → 155

b → 417

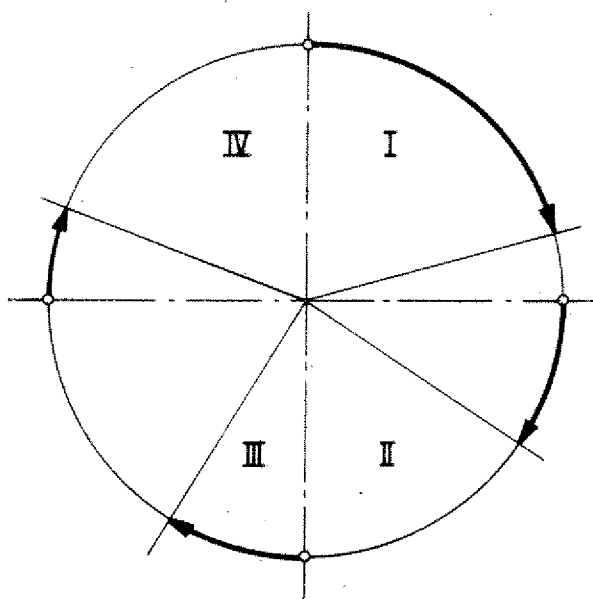

The statement of angles is always programmed from the quadrant start.

Thus, the a,b values may have X,Y and Z characteristics.

Exercise:

Put in the a,b values of quadrants IV and I.

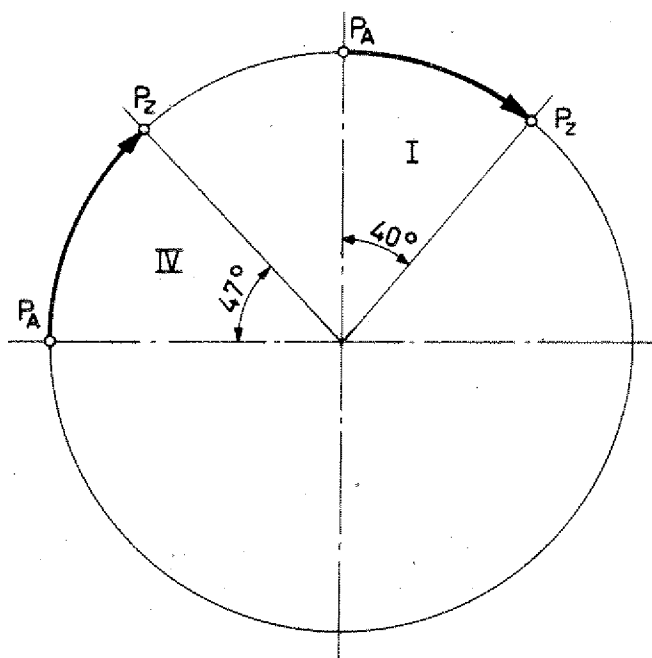

Radius 10 mm

	IV	I
a		
b		

Radius 27 mm

	IV	I
a		
b		

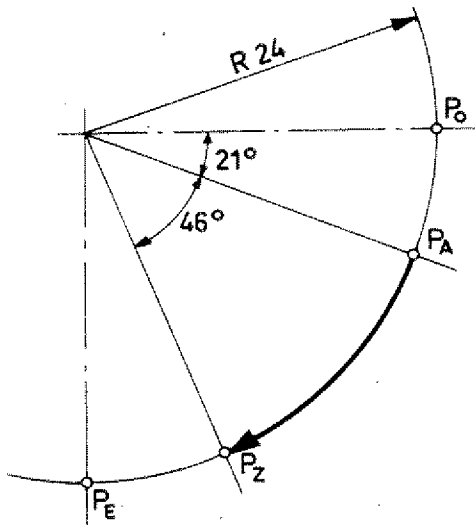

Exercise:

Put in the coordinates for P_O , P_A , P_Z and P_E .

Radius 10 mm

	X	Y
P_O		
P_A		
P_Z		
P_E		

Radius 38 mm

	X	Y
P_O		
P_A		
P_Z		
P_E		

Programming of Arcs $\neq 90^\circ$ in absolute Mode

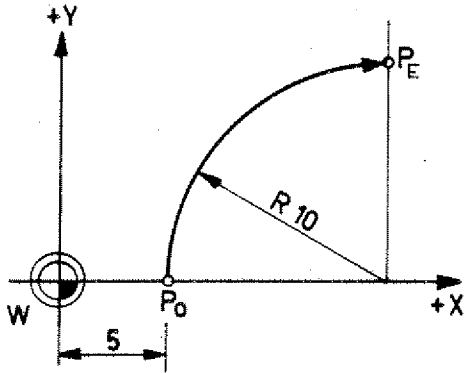

For a better understanding some details on the F1-CNC computer:

In the memory (RAM) the 90° arcs (Quadrants) are stored -

with the block:

```
N.../G02/X=1500/Y=1000/Z....
```

The computer knows

- sense of rotation (G02)
- position and size of the 90° arc (statement of coordinates of end point PE of 90° arc).

The starting coordinate P_0 of the 90° arc is known to the computer from the previous block.

In the computer, this quadrant is divided into 90 steps of 1° each.

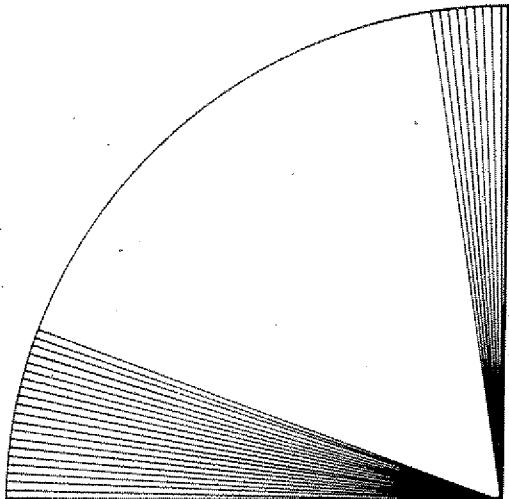

Manufacture of the 90° arc

The computer instruction is:

Traverse all 90 steps of the programmed quadrant.

Programming of Arcs from 0° to $\alpha \neq 90^\circ$

We instruct the computer to edit only a part of the 90 steps.

This is done with the M99 information

J=0 to K=30

Flow in the computer

```
N99/G01/X=0/Y= 500/Z.....
N100/G02/X=1500/Y=1000/Z.....
N101/M99/J=0/ K=30
```

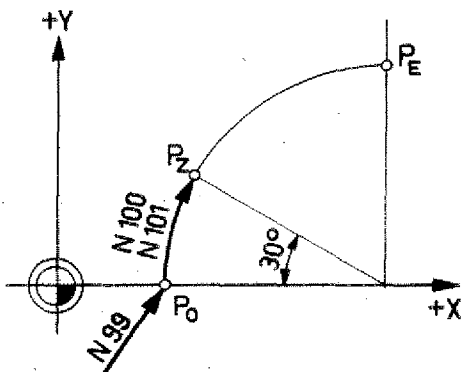

1. The computer checks whether starting and end coordinates of the 90° arc are correct.

It compares the coordinates of blocks N99 and N100.

2. The computer asks whether there is a M99 instruction in the following block.

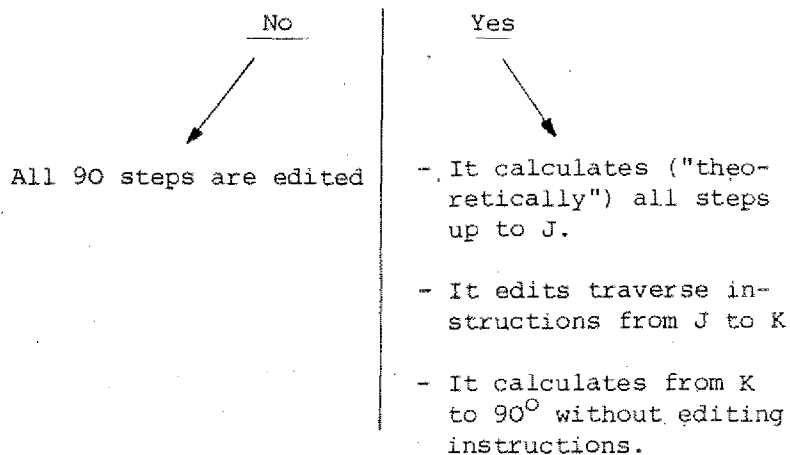

Programming $\alpha \neq 0^\circ$ to $\alpha = 90^\circ$ in absolute Mode

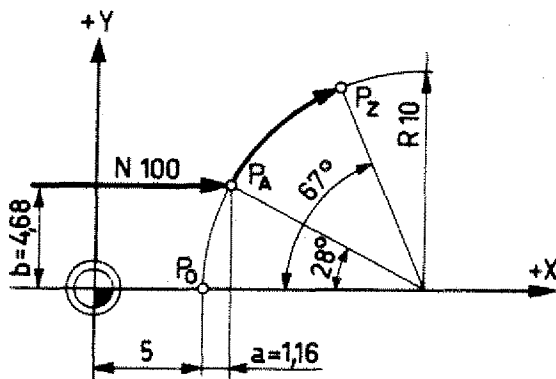

1. Programming to point PA

N100/G01/X616/Y468/Z....

2. Arc = 28° to 67°

2.1. Description of the 90° arc:

N101/G02/X1616/Y1468/Z....

The absolute coordinates of the quadrant end point PE are described starting from point PA.

By computation this is the end point of the quarter arc.

$$XE = XA + /R/$$

$$YE = YA + /R/$$

$$ZE = ZA$$

2.2. N102/M99/J28/K67

Flow of data in the computer - Manufacture

1. The computer checks whether coordinates of starting point PA and quadrant end point PE are correct (absolute).

2. M99 instruction exists.

a) Computer proceeds up to J28 ($= 28^\circ$) - without traverse instruction.

b) It gives traverse instructions from J28 to K67 (28° - 67°). The impulses from J28 to K67 are worked through. The indicated quadrant is manufactured - from starting point PA to target point PZ.

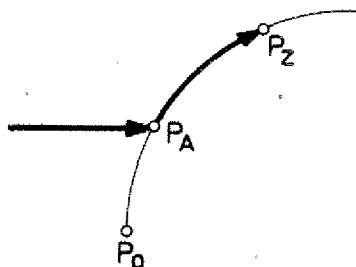

A Method of programming Arcs $\alpha \neq 90^\circ$ (absolute)

With partial arcs $\alpha \neq 90^\circ$ it is often necessary to calculate starting and target point of the previous and the following blocks: thus it is useful to establish a chart.

Specification:

- PA - Starting point of partial arc of circle
- PZ - Target point of partial arc of circle
- PE - End point of quadrant ("theoretical" target point)
- PO - Starting point of quarter arc.

Examples:

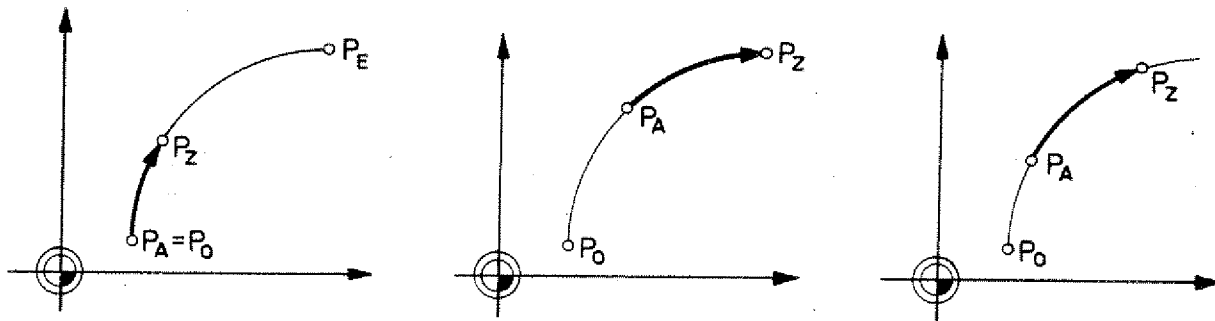

Coordinates

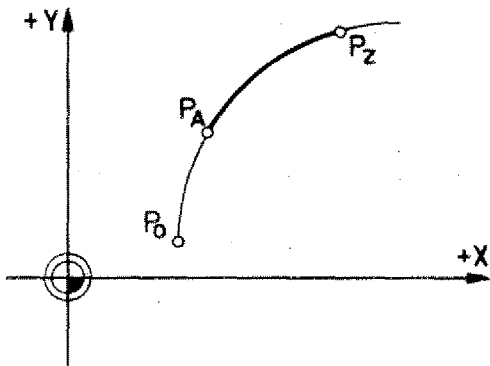

PA: PA is the target point of the block before the circle programming

XA

YA

ZA

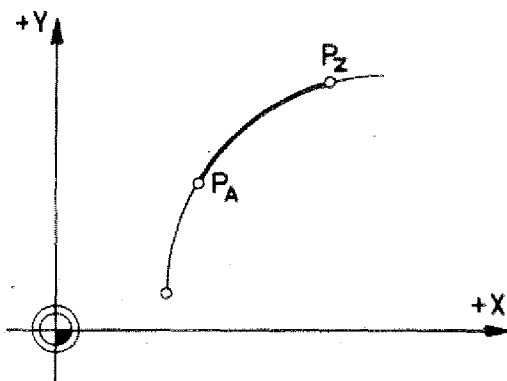

PE: "Theoretical" end point of the quarter arc

$$XE = XA + R$$

$$YE = YA + R$$

$$ZE = ZA \text{ (interpolation in the plane)}$$

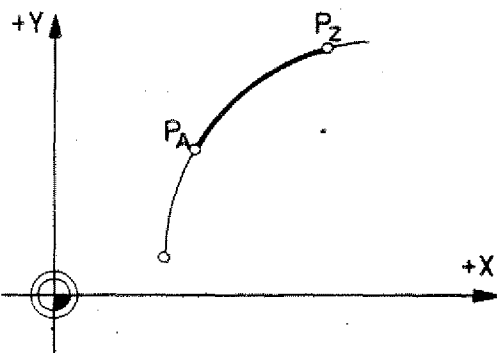

PZ: Programmed target point

$$XZ = XA + \Delta X$$

$$YZ = YA + \Delta Y$$

$$ZZ = ZA \text{ (interpolation in the plane)}$$

Coordinates path of the partial radius

$$\Delta X = XPZ - XPA$$

$$\Delta Y = YPZ - YPA$$

$$\Delta Z = 0 \text{ (interpolation in the plane)}$$

PO: Theoretical starting point of the quarter arc

$$XO = XA - a$$

$$YO = YA - b$$

$$ZO = ZA$$

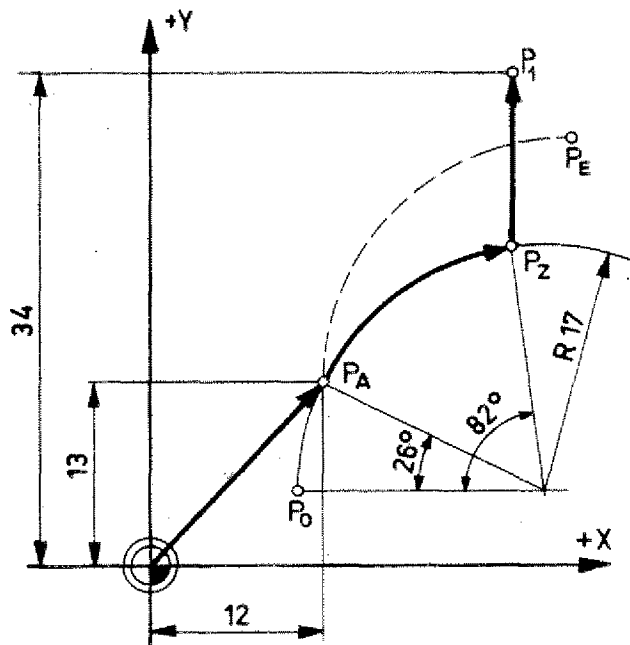

Exercise:

Put in X,Y-values, Z-value = 0

Program path
W - PA - Pz - P1

PA	X	Y	Z
PE			
Pz			
Po			

N	G (M)	X (J) (D)	Y (K) (S)	Z	F (L) (T) (H)	remarks

G04 – Dwell

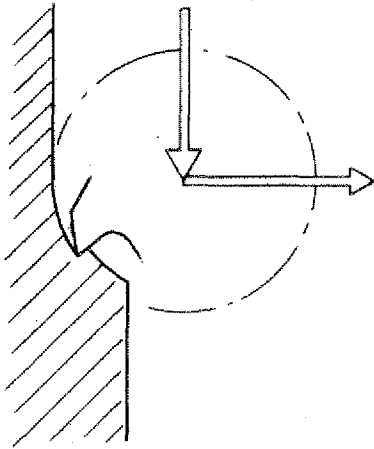

If you manufacture a borehole and withdraw the drill after you have reached the desired depth, then the chip will be torn off. The base of the borehole has steps.

With boreholes of tapered shape this often does not matter. With shouldered boreholes, however, it can be disturbing.

The same applies for milling cutters of larger diameter or for fly wheel cutter if you move away suddenly.

You have an unwanted shoulder in the workpiece.

In such cases a dwell should be programmed.

Programming

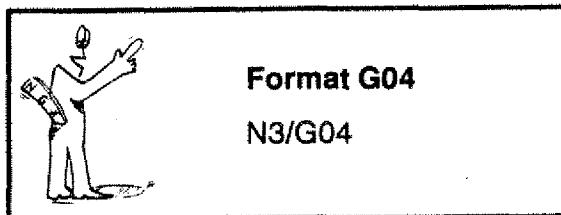

The tool remains 0,5 seconds in the programmed position of the previous block.

G21 – Empty Line

You may program as many empty lines as you wish in a program.

The empty lines are jumped over in the program sequence.

In the place of empty lines you can program at later stage other G- or auxiliary functions.

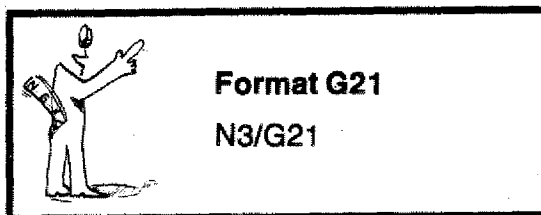

Subroutines G25/M17

The subroutines are "managed" by the main program.

In the main program the movements are programmed up to the starting point for the subroutines.

MAIN PROGRAM

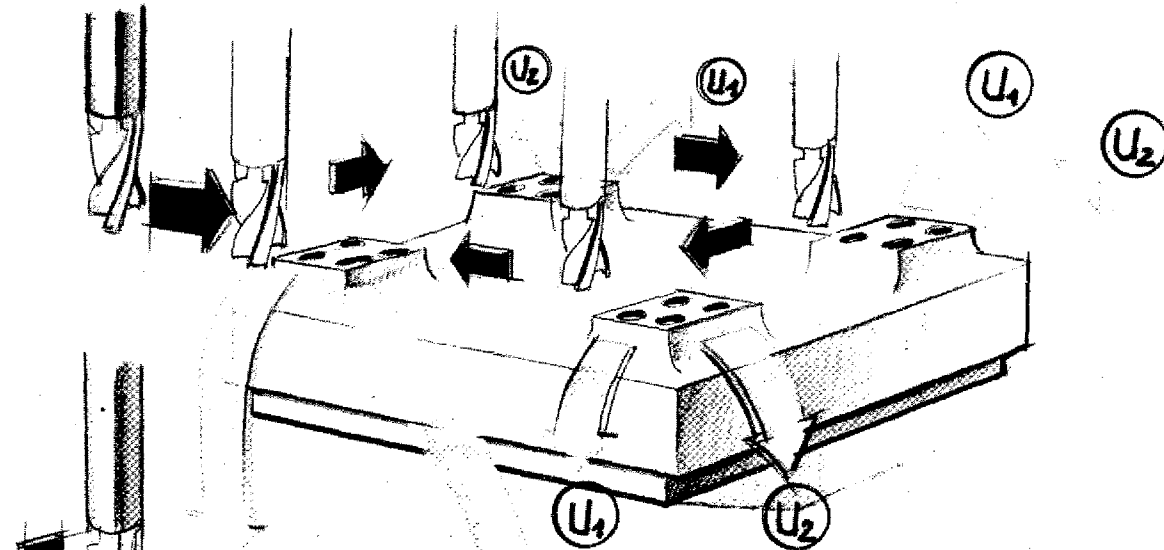

SUBROUTINE 1

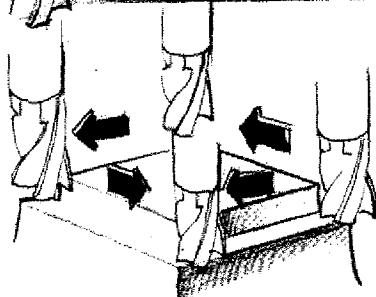

At the end of a subroutine the instruction is given to carry on with the main program.

SUBROUTINE 2

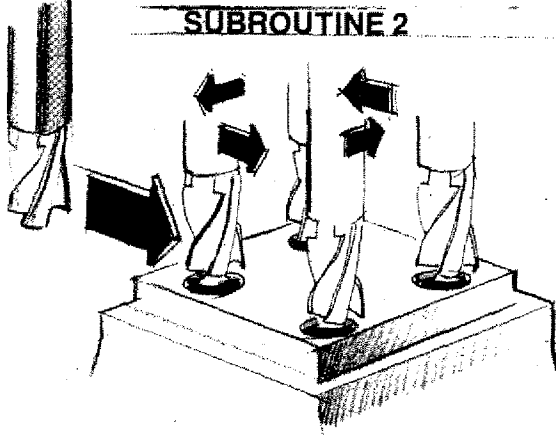

Subroutines

It happens quite often that various milling operations of same shape are manufactured at one and the same workpiece.

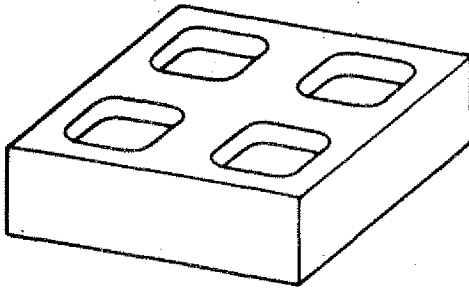

Example

- 4 geometrically identical pockets.
- For the manufacture of each pocket the milling cutter has to be moved to working position.
- The programming and manufacturing process is the same for each individual pocket. You program in one program pocket milling for 4 times.

These identical operations may be programmed just once and then "stored". If they are needed they are called up

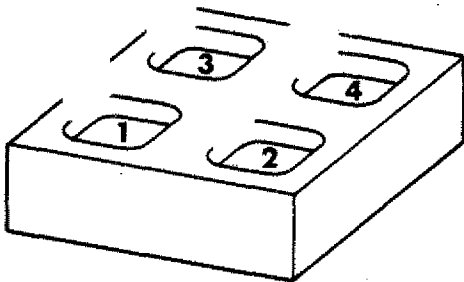

To our example

1. The tool is moved to the first milling start point.
 2. The subroutine is called up. The first pocket is being milled.
 3. The tool is then moved to the second milling start point.
 4. Subroutine is called up.
 5. The tool is then moved to the third milling start point.
 6. Subroutine is called up.
- etc.

— Start and endpoint of
subroutine

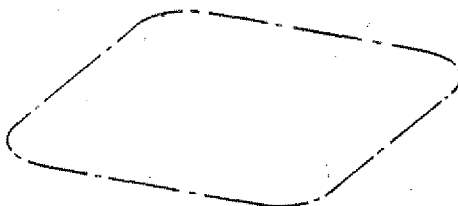

Subroutine

Principle: Call-up of Subroutine and Sequence on F1-CNC

MAIN PROGRAM

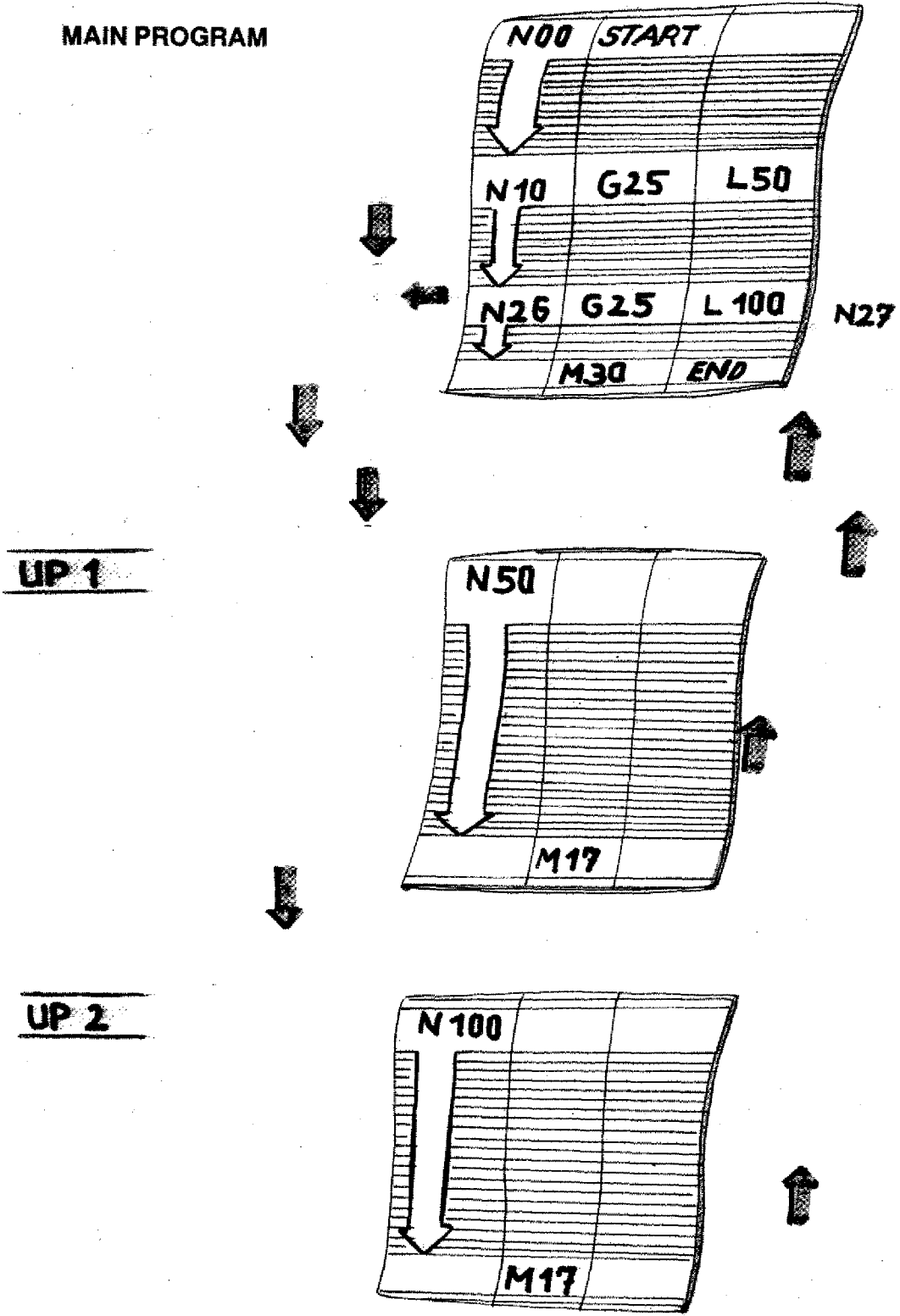

Subroutine-Programming

G25 Jump to Subroutine

M17 Jump back to Main Program

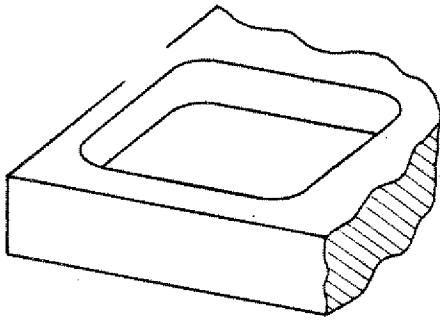

1. Programming up to the first start of the subroutine (assume N05).

2. Call up subroutine G25 in block N06:
N06/G25/L100

- With G25 the subroutine is called up.

- Under the F-address we describe the block number with which the subroutine begins.

In this case the subroutine begins with block no. N100 (the block no. is selected by the programmer).

3. The subroutine:

```
N100/  
N101 ...  
N102 ...  
N103 ...  
N104 ...  
N105/G01
```

In the subroutine the operation to be repeated is described (block N100 to block N105)

4. Jump back instruction M17:

At the end of a subroutine you have the jump back instruction M17. The program jumps to the following block with which the subroutine was called up.

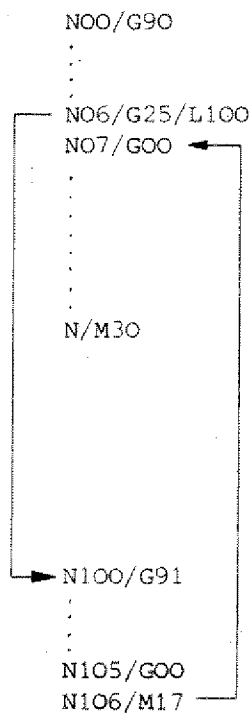

Example

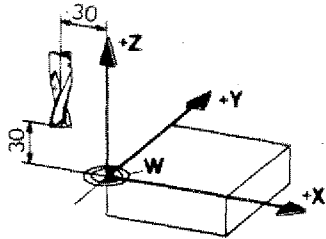

- Programming main program: absolute
- Programming subroutine: incremental
- Zero point of workpiece as in drawing
- Reference point set-off as in drawing
- Diameter of milling cutter 8 mm

Continue the program. Start point shall be end point of program.

In block NO5 the workpiece zero-point is programmed again.

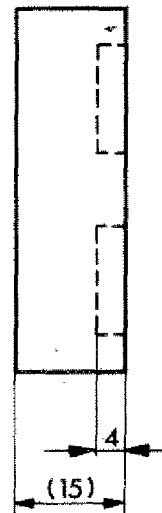
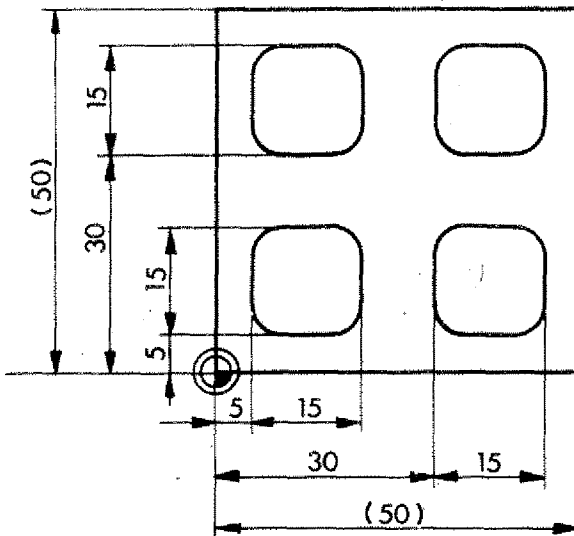

N	G (M)	X (J) (D)	Y (K) (S)	Z	F (L)(T)(H)
00	92	-3000	0	3000	
1	M06	D400	S2000	0	T01
2	00	900	900	3000	
3	00	900	900	200	
4	25				L50
5	92	900	900	200	
6	00	3400	900	200	
7	25				L50
8					
9					

50	91				
51	01	0	0	-600	70
52	01	700	0	0	140
53	01	0	700	0	140
54	01	-700	0	0	140
55	01	0	-700	0	140
56	00	0	0	600	
57	M17				

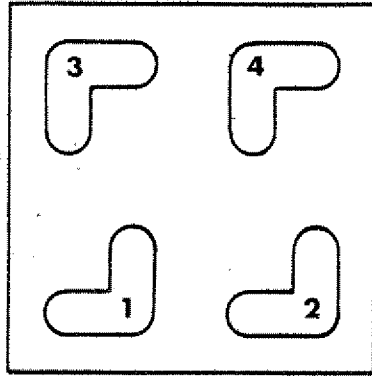

More Subroutines

You can write as many subroutines in a program as you like.

Example

The slots 1 + 2 are subroutine no. 1.
 The slots 3 + 4 are subroutine no. 2.
 The program shows an incremental main program.

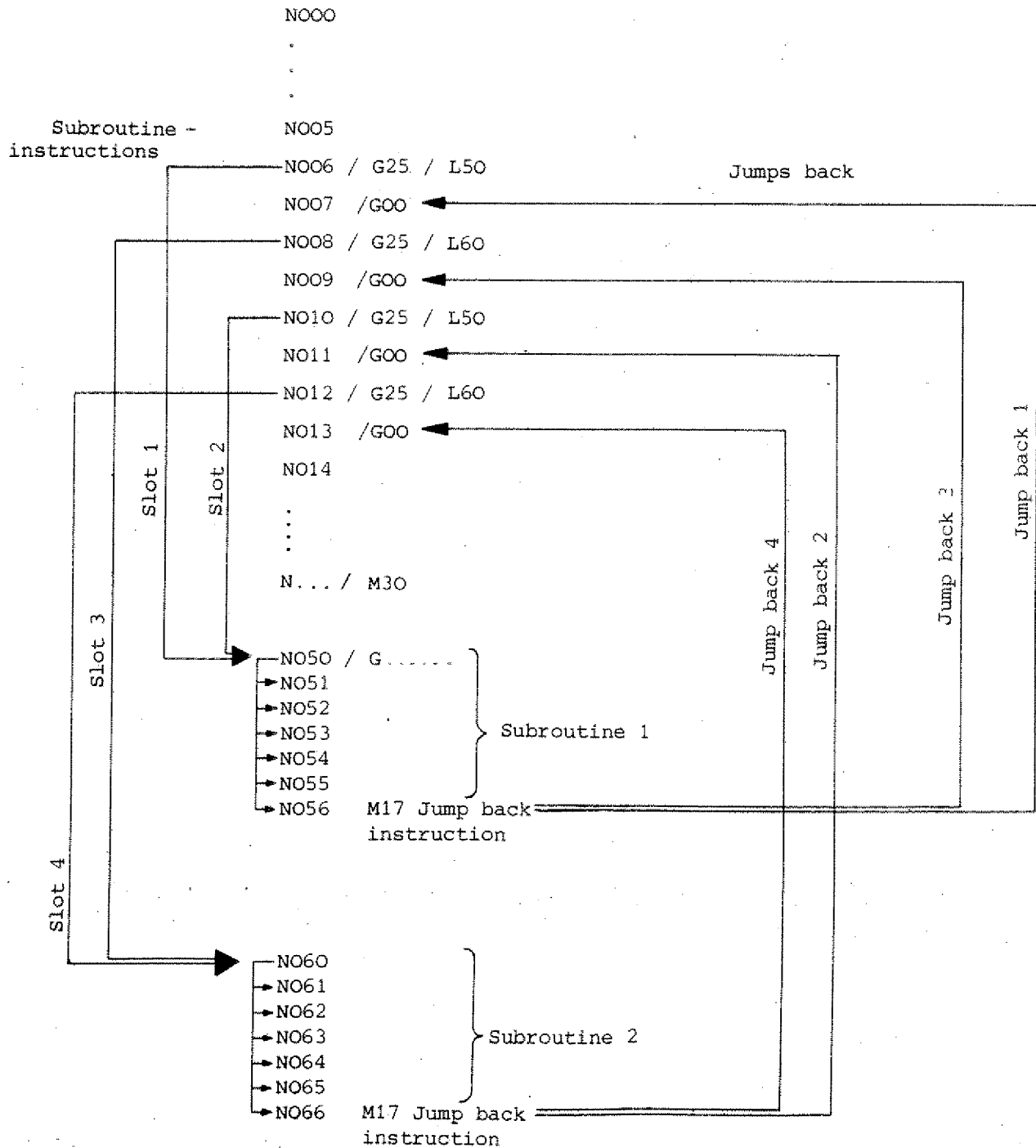

Example

- Program the workpiece with 2 sub-routines.
- Start point as in drawing.
- Zero point of workpiece as in drawing.
- Subroutines in incremental mode.
- Diameter of milling cutter 6 mm.

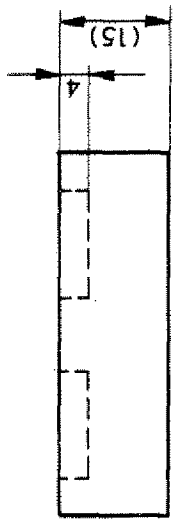
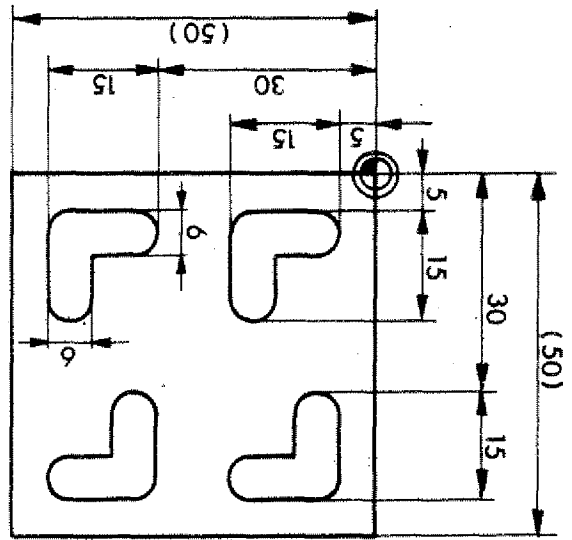
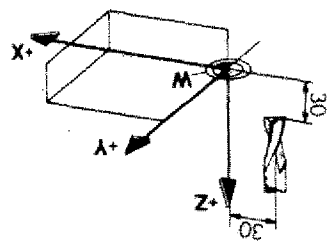

N	G	(M)	X	(J)	(D)	(K)	(S)	Y	Z	F	(L)	(T)	(H)
---	---	-----	---	-----	-----	-----	-----	---	---	---	-----	-----	-----

N	G	(M)	X	(J)	(D)	(K)	(S)	Y	Z	F	(L)	(T)	(H)
---	---	-----	---	-----	-----	-----	-----	---	---	---	-----	-----	-----

Part of a subroutine

You can also call up parts of subroutines.

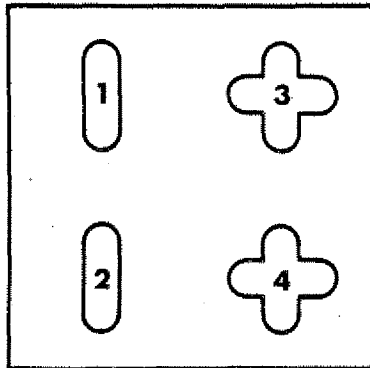

An example:

- Slot (1) and slot (2) are identical and contained in cross slot 3 and 4.
- You write a subroutine for slot 3 and 4.
N100/G91
N101/G01 to

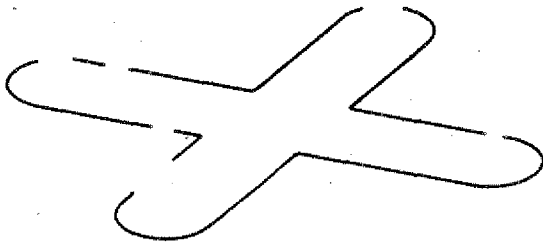

N108
N109/M17
You can use block N105 to 108 for the manufacture of slot 1 and 2.

It is possible to call up parts of a subroutine.
In this example:

Block N105 to N109 / M17

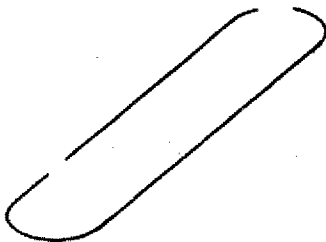

Part of a subroutine program

The scheme shows an incremental main program. In an absolute main program you have to determine the workpiece zero-point with G92.

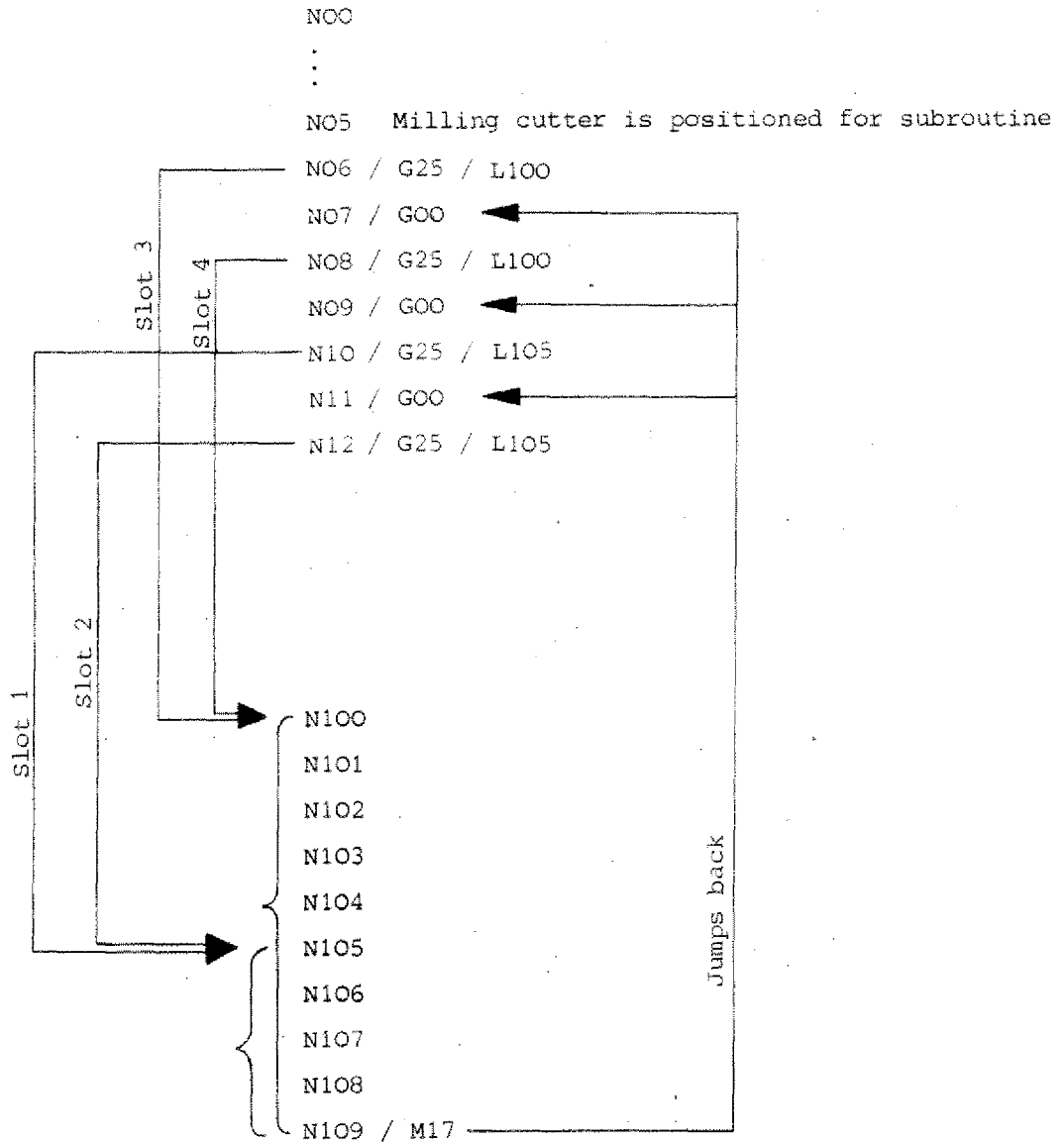

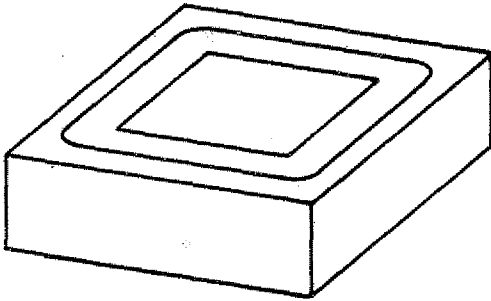

Example:

You have to mill a rectangular slot. Since the slot is deep you need a few runs; these are identical in the XY-plane.

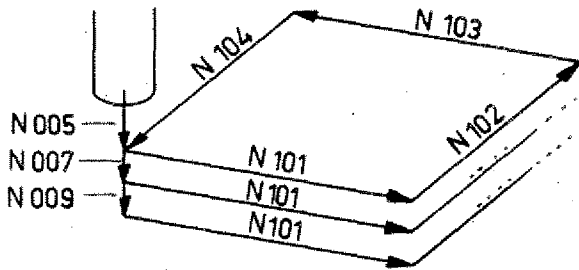

Example:

- Mill cutter is already cutting at block no. N005.
- N006 is jump to subroutine.
- The subroutine consists of block N101 to N105.
- N105 is jump back to main program.
- N007 is infeed in main program.
- N008 is jump to subroutine.
- etc.



Exercise

- Make a sketch indicating the start point.
- Determine the zero point (W)
- Main program: absolute
- Circular slot in 2 runs

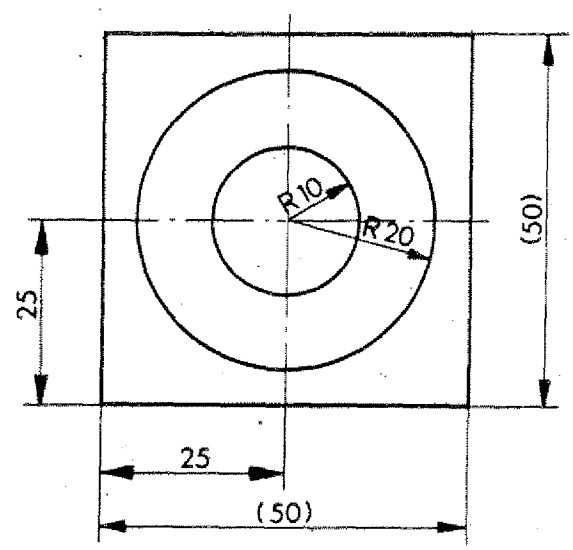

Depth of slot 10 mm

N	G (M)	X (J) (D)	Y (K) (S)	Z	F (L)(T)(H)

The Nesting of Subroutines

Call-up - Sequence

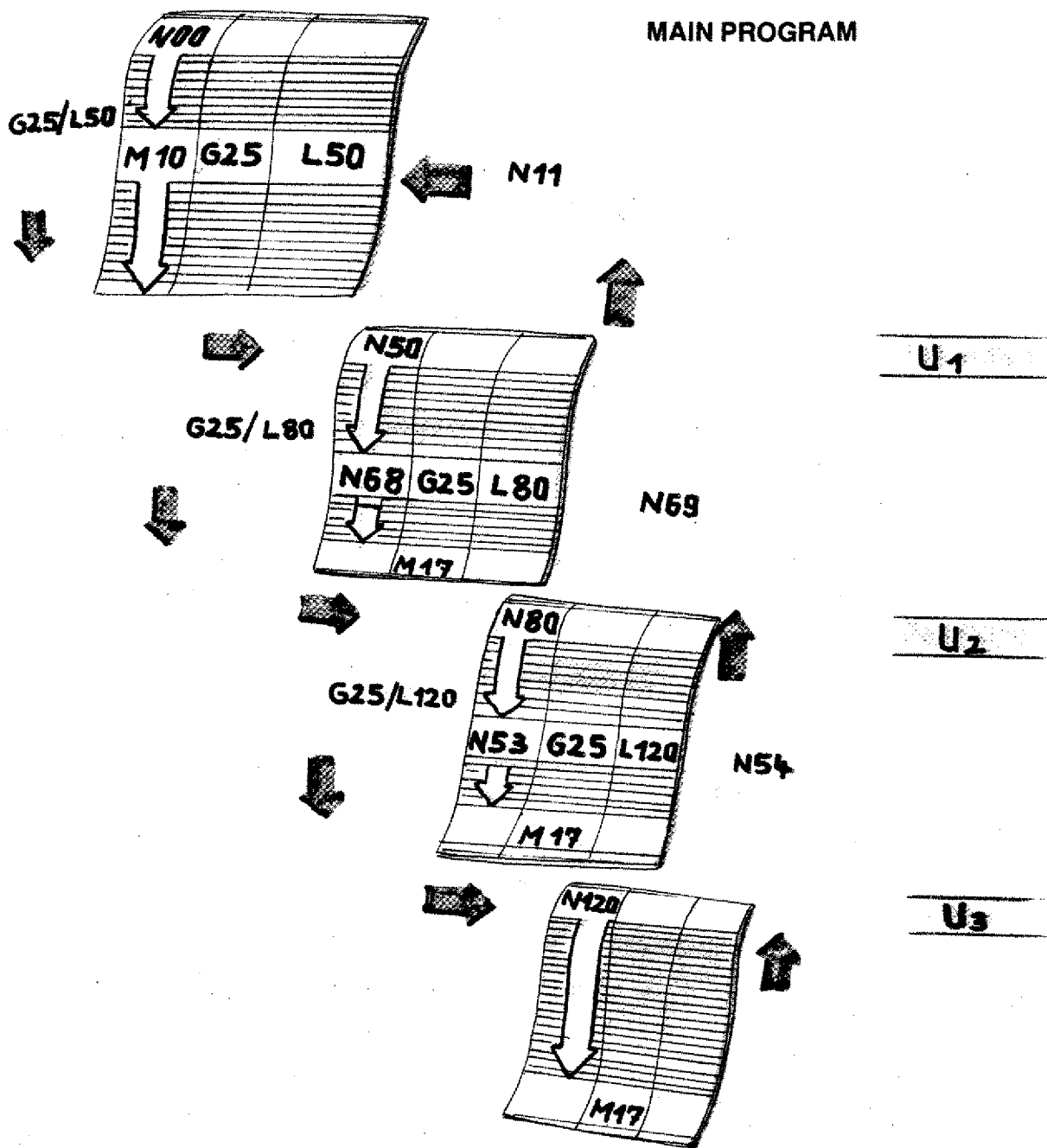

G27 - Jump Instruction

Format N3/G27/L3

N	G (M)	X (J) (D)	Y (K) (S)	Z	F (L) (T) (H)
17	27				110
18					
:					
:					
110					
:					
:					
120	27				018

With this instruction you can jump forward or backward within the program.

- Under the L(F) address the block is programmed until to the one where the program shall be skipped.

Example

Block 17
Instruction to jump to block 110

Block 120
Instruction to jump back to N18

N	G (M)	X (J) (D)	Y (K) (S)	Z	F (L) (T) (H)
3	21				
4					
} finishing program					
12					
13					
14					

Application

- The surface of the workpiece shall be worked or not.
- You describe a finishing program (N4 to N12).
- In the block preceding the finishing operation you program G21.
- In blocks N4 to N12 the finishing cut is carried out.

N	G (M)	X (J) (D)	Y (K) (S)	Z	F (L) (T) (H)
3	27				13
4					
} finishing program					
12					
13					
14					

Jump instruction

If the surface should remain unfinished:
Delete N3/G21
Program N3/G27/L13

The blocks N4 to N12 are skipped.

The Cutter Radius Compensation – Parallel to Axis

- G40 – Cancel the compensation
- G45 – Add cutter radius
- G46 – Deduct cutter radius
- G47 – Add cutter radius twice
- G48 – Deduct cutter radius twice

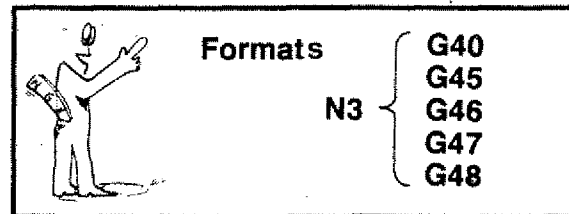

G45/G46/G47/G48 are self-maintaining functions. They are revoked by G40 or M30 (program end). G45 can be overwritten by G46/G47/G48 and vice-versa.

Before programming G45/G46/G47/G48 you have to describe the tool data under M06.

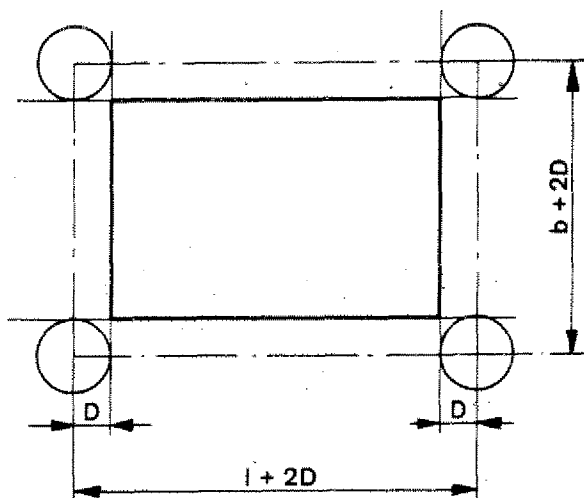

In examples up to now we have always been programming the center line path of the cutter. With the lengths to be worked the cutter radii had to be added or deducted. This calculation work can be taken over by the computer, if appropriate informations are given.

G45 – Adding Milling Cutter Radius

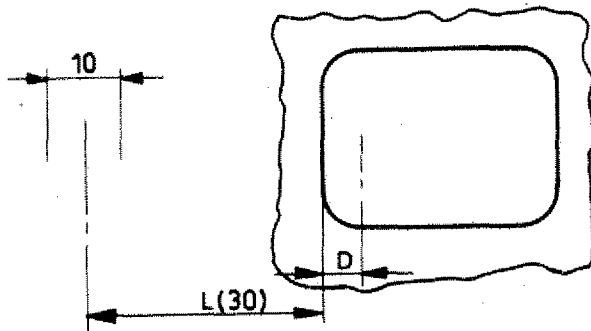

Programming incremental

The milling cutter shall touch the inside of the contour.

Conventional programming:

N.../G00/X=1+r/

The radius has to be added to the length l.

Programming with G45 (Adding Cutter Radius)

N	G (M)	X (J) (D)	Y (K) (S)	Z	F (L)(T)(H)
...	M06	D 500	S 2000	0	T01

1. The computer has to know the cutter radius so that it can calculate the correct movement $(l + r)$.

In one of the previous blocks the tool data have to be described, otherwise alarm sign A18.

...	M06	D 500	S 2000	0	T01
...	G45				

2. Call up G45:•
Add cutter radius once.

...	M06	D 500	S 2000	0	T01
	G45				
...	00	3000	0	0	

3. Program movement.
Measure L (30)

The computer picks up the tool data from the M06 instruction which was programmed last.

Cancel the cutter radius compensation:
N.../G40

G46 – Deducting the Cutter Radius

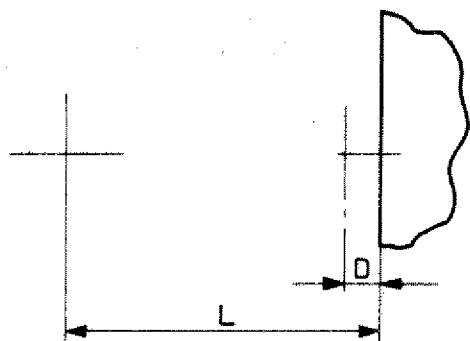

Mode of programming: incremental

Cutter shall touch outer contour.
Cutter dia. 10 mm

Programming:

```
N100/M06/D500/S2000/Y=0/T(F)1
N101/G46
N102/G01/X=L/Y=0/Z=0/F...
```

The cutter moves by the distance $L-D$.

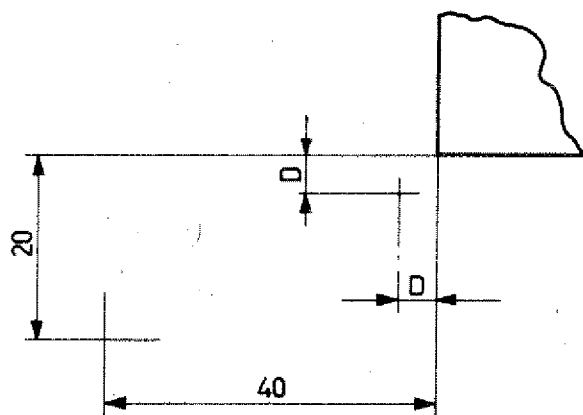

Approaching an Edge – Not parallel to Axis

Programming: incremental

Cutter dia. 16 mm
Reference dimension $H_z = 0$

```
N01/M06/D800/S1700/Y=0/T(F)1
N02/G46
N03/G01/X4000/Y2000/Z=0/F...
N04/M30
```

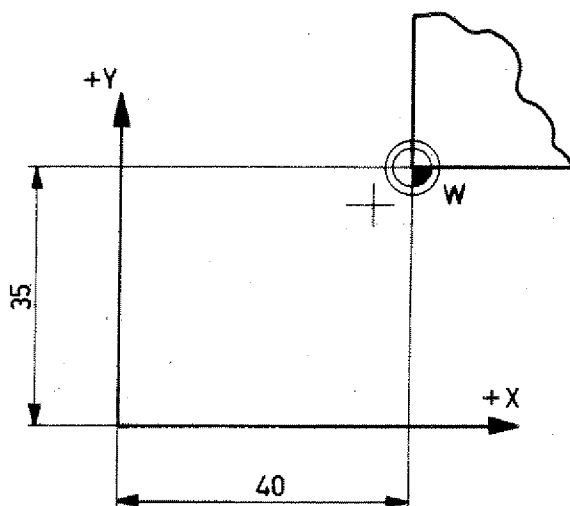

Approaching an Edge – Not parallel to Axis

Programming: absolute

- Cutter dia. 16 mm
- Zero-point as in drawing

```
N00/G92/X-4000/Y-3500/Z1000/
N01/M06/D800/S2000/Z=0/T01
N02/G46
N03/G00/X=0/Y=0/Z1000
N04/M30
```

G47 – Add Cutter Radius Twice

- Outside contour shall be milled
- Mode of programming: incremental
- Cutter radius 6 mm
- Starting point as in drawing

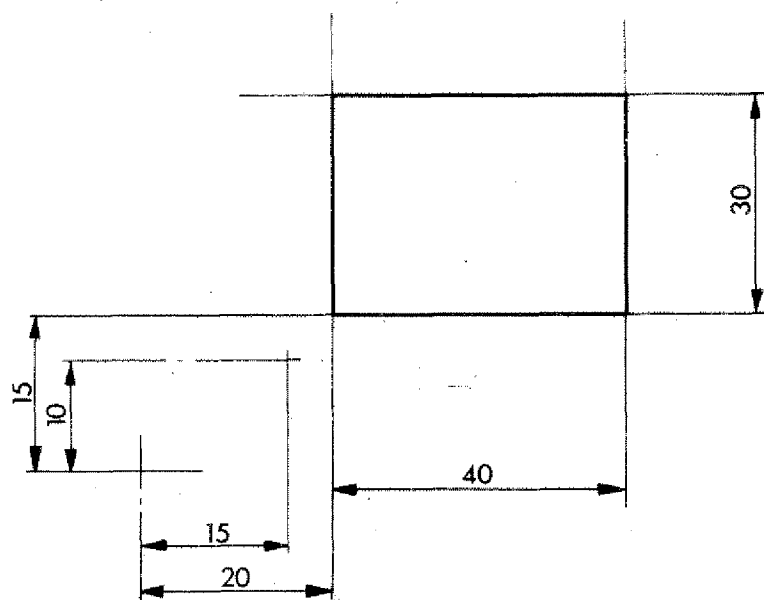

Programming:

```

N000/M06/D600/S2000/Z=0/T(F)1
N1/G46
N2/G01/X2000/Y1500/Z=0/F...
N3/G47
N4/G01/X4000/Y=0/Z=0/F...
N5/G01/X=0/Y3000/Z=0/F...
N6/G01/X -4000/Y=0/Z=0/F...
N7/G01/X=0/Y -3000/Z=0/F...
N8/G46
N9/G00/X -2000/Y -1500/Z=0/
N10/M30

```

Block N4 to N7

Cutter radius is added twice.

Block N02, N9

Cutter radius is deducted once.

Cutter path plotted

Programming exercise:

Cutter radius 5 mm

Incremental programming

Starting from point P₁.

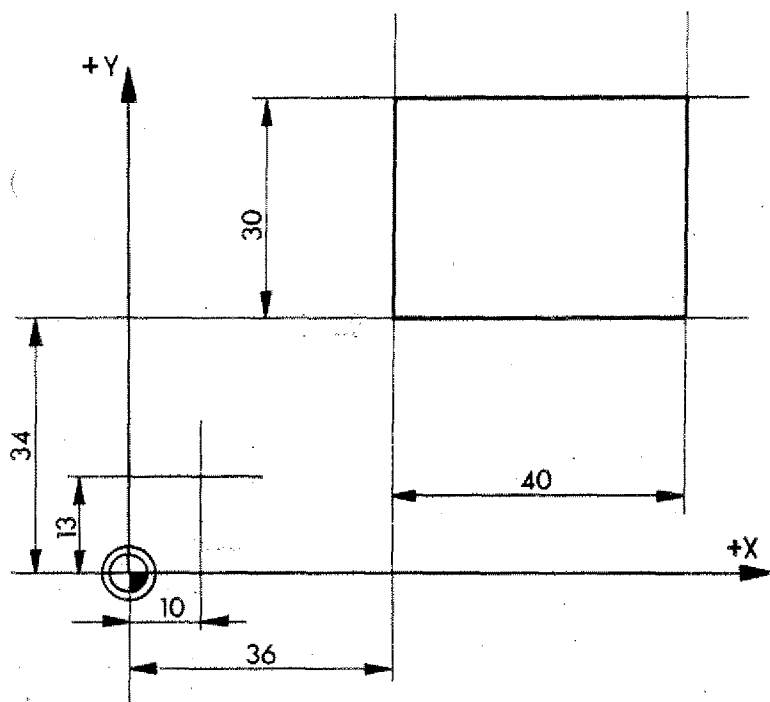

N	G (M)	X (J) (D)	Y (K) (S)	Z	F (L) (T) (H)

Absolute programming

Determining the zero-point starting from point P₁.

N	G (M)	X (J) (D)	Y (K) (S)	Z	F (L) (T) (H)

G48 – Deduct Cutter Radius Twice

Example: Milling an inside contour

- Milling cutter radius 6 mm
- Mode of programming: incremental

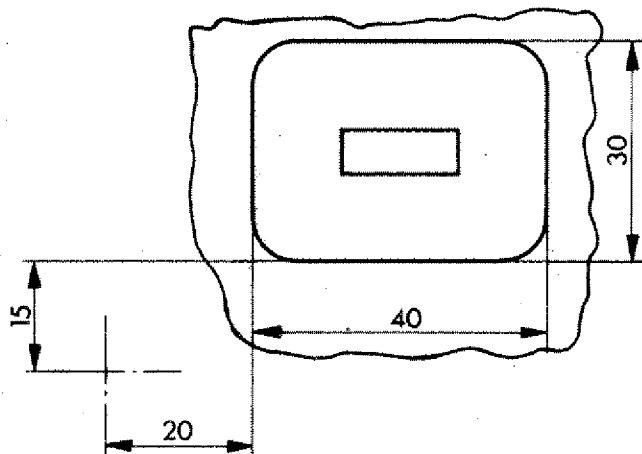

Block N3: move in
 Block N5 - N8: inside contour
 Block N9: move out of inside contour
 Block N11: withdrawal to starting
 position

Program:

```

N000/M06/D600/S2000/Y=0/T(F)1
N1/G45
N2/G00/X2000/Y1500/Z=0
N3/G01/X=0/Y=0/Z -500/F...
N4/G48
N5/G01/X4000/Y=0/Z=0/F...
N6/G01/X=0/Y3000/Z=0/F...
N7/G01/X -4000/Y=0/Z=0/F...
N8/G01/X=0/Y -3000/Z=0/F...
N9/G01/X=0/Y=0/Z500/F...
N10/G45
N11/G00/X -2000/Y -1500/Z=0/F...
N12/M30
  
```

Cutter path plotted in one plane

Example: Combined Inside-/Outside Contour

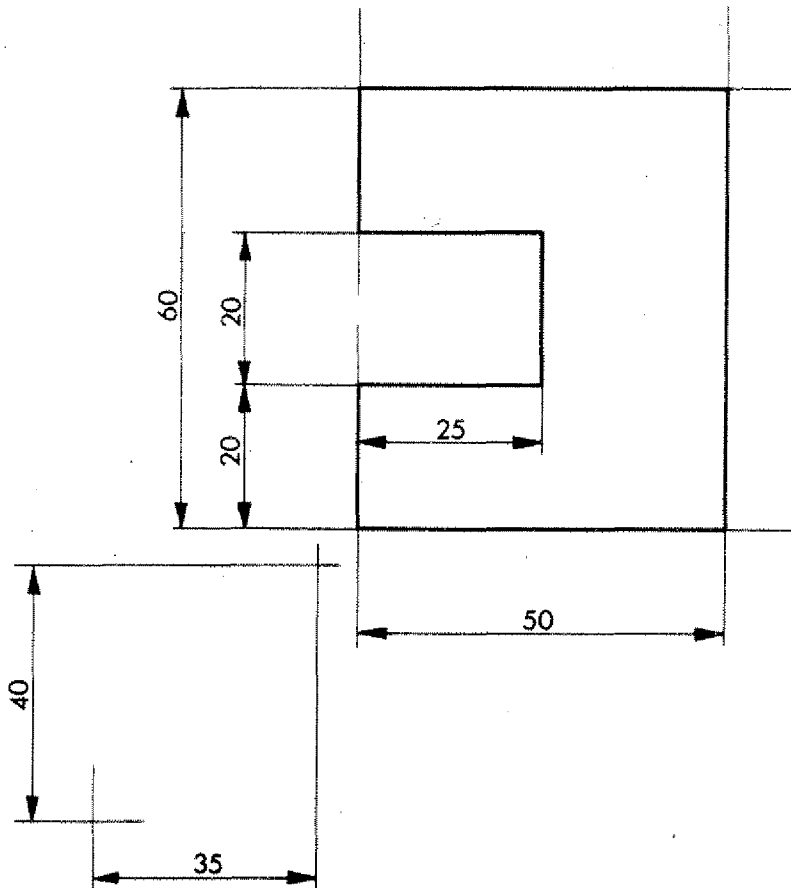

Mode of programming: incremental
Milling cutter radius 5 mm

N	G (M)	X (J) (D)	Y (K) (S)	Z	F (L)(T)(H)	remarks
00	M06	D 500	S 2000	0	T01	
1	46					
2	00	3500	7000	0		
3	47					
4	01	0	2000	0	100	
5	40					
6	01	2500	0	0	100	
7	48					
8	01	0	2000	0	100	
9	40					
10	01	-2500	0	0	100	
11	47					
12	01	0	2000	0	100	
13	01	5000	0	0	100	
14	01	0	-6000	0	100	
15	01	-5000	0	0	100	
16	46					
17	00	-3500	-1000			
18	M30					

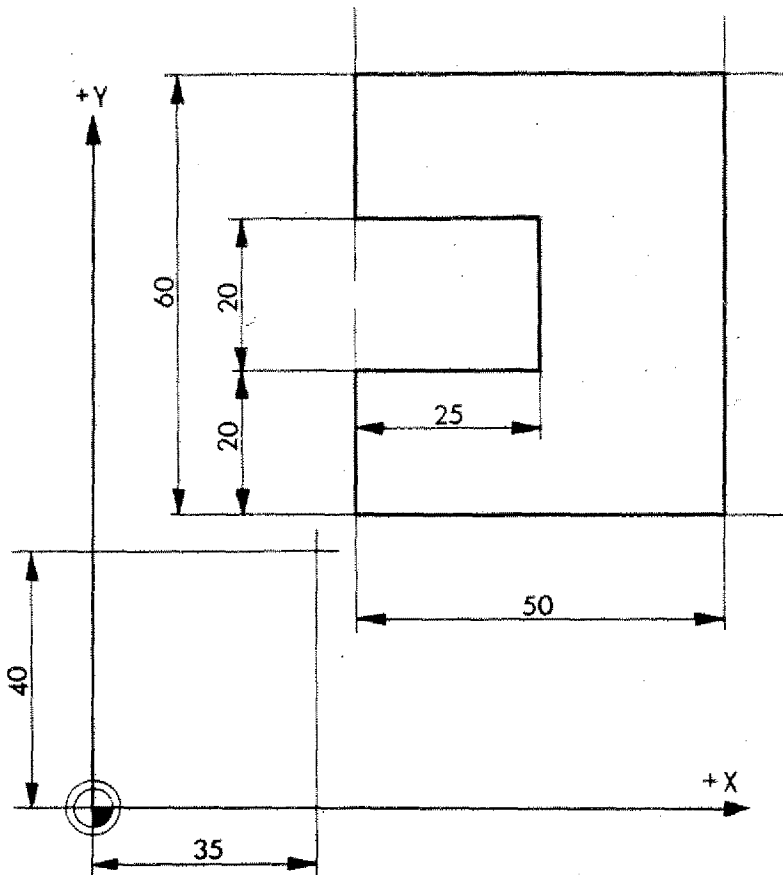

Exercise:

- Program the example in absolute mode.
- Zero point as in drawing.
- Cutter radius 5 mm

N	G (M)	X (J) (D)	Y (K) (S)	Z	F (L) (T) (H)	remarks

G64 – Switching Feed Motors Currentless

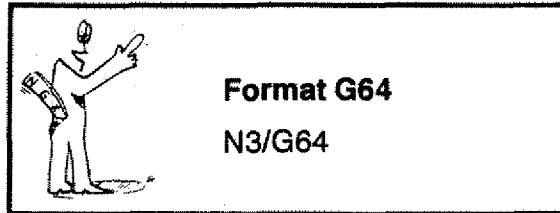

The previously programmed G- and M-codes remain stored.

Switching currentless with program stored

G64 is a pure switching function. It is not stored.

1. Press key until G-lamp flashes.
2. When a number appears on the VDU, press key .
3. Key in .
4. Press key , the feed motors are now currentless.

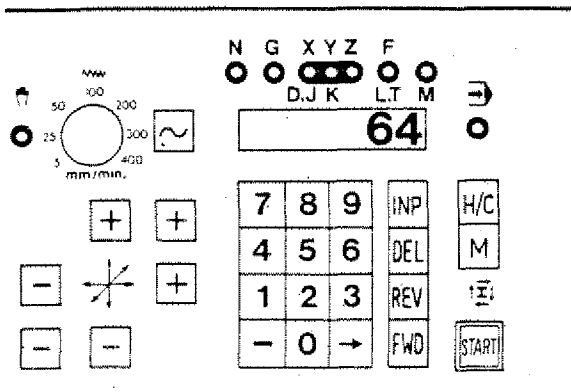

G72 – Pocket Milling Cycle

Pockets are a quite common shape when milling. The programming work of many single blocks can be put together to a cycle. The computer offers a fixed sequence = cycle.

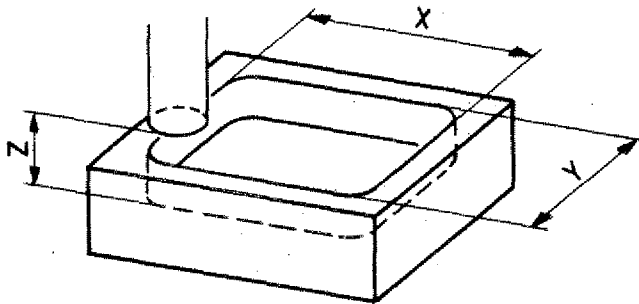

Programming G72

1. G72
2. X-value, inside dimension of the pocket in X-direction.
3. Y-value, inside dimension of the pocket in Y-direction.
4. Z-value = depth of pocket
5. F-value



Format G72
 $N3/G72/X \pm 5/Y \pm 4/Z \pm 5/F3$

N	G (M)	X (J) (D)	Y (K) (S)	Z	F (L) (T) (H)
	M06				
...	G72				

With this block the machine cannot mill a pocket yet.

- It does not know the radius of the cutter and thus cannot calculate the movements.
- Therefore, the tool has to be described in one of the previous blocks (M06).

The computer uses these data (cutter radius) to calculate the effective movements which were programmed last.

If no M06 was programmed before, alarm sign 18 will appear.

Pocket Milling Sequence

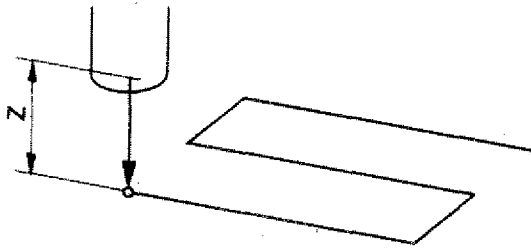

The milling cutter has to be positioned before the pocket milling can start.

1. The cutter moves into the pocket by the Z-value, if a Z-movement is programmed.

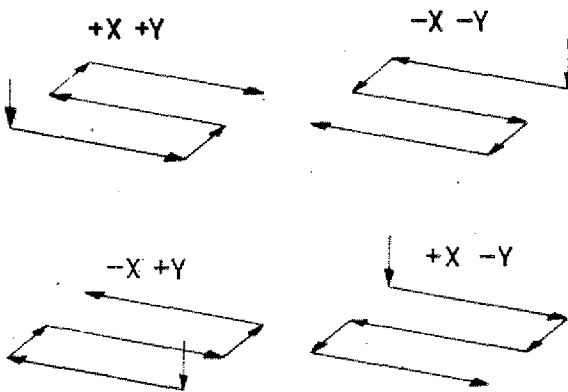

2. Milling out (reaming) a pocket:

- The first movement is in X-direction.
- The signs determine the sequence of the traverse.

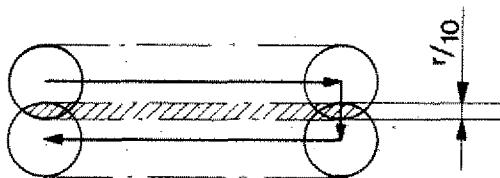

Overlap:

The overlap is 1/10 of the cutter radius (with 5 mm radius approx. 0,5 mm).

The computer takes the information about the radius from the MO6 block which was programmed last.

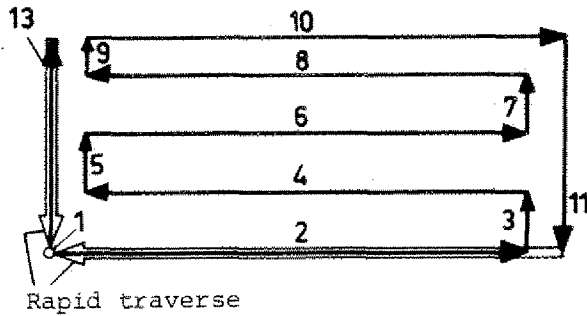

3. Finishing ram:

The sides are being finished. Traverse 10/11/13. Finishing measure approx. 1/10 of the cutter radius.

4. Cutter moves out of pocket (Z-direction) into starting position.

The pocket milling cycle is complete.

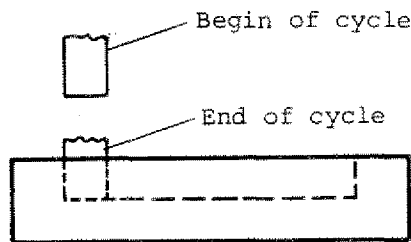

Pockets can be programmed in absolute or incremental mode.

Incremental programming:

X,Y,Z values are given from the starting position.

Technological tip

When moving in a milling cutter the feed should be approx. half of the normal cutting feed.

Therefore it is advisable to program this first movement in an extra block.

Summary G72 (M06)

With pocket in XY-plane

N.../M06/D(X) ○ /S(Y) ○ /Z(H_z) ○ /T(F) ○
 ⋮
 Data for calculation of cutter path
 N.../G72/X ○ /Y ○ /Z ○ /F ○
 X-value Y-value Z-value

M06

- D(X) = Cutter radius
- S(Y) = Speed
- Z = H_z-value
- T(F) = Tool number

- X = Inside measurement of pocket
- Y = Inside measurement of pocket
- Z = Infeed depth
- F = Feed

The computer will calculate all reference points automatically.

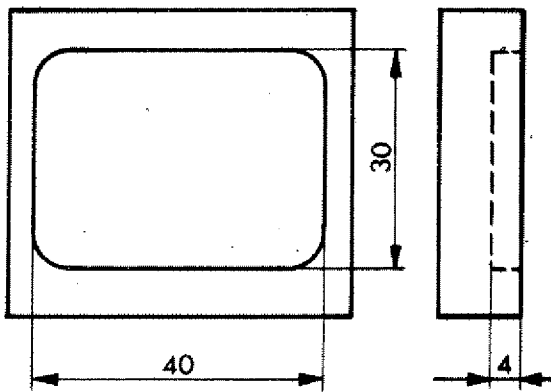

Start and target position

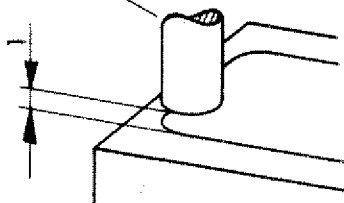

Example:

- + Cutter diameter 10 mm
- + The pocket is programmed incrementally
- + Start position for cycle as in drawing.

N	G (M)	X (J) (D)	Y (K) (S)	Z	F (L) (T) (H)
05	00				
06	M06	500	2000	0	01
07	G72	4000	3000	-500	0.2

- N5 = Move to start position
- N6 = Tool data
- N7 = Pocket milling cycle

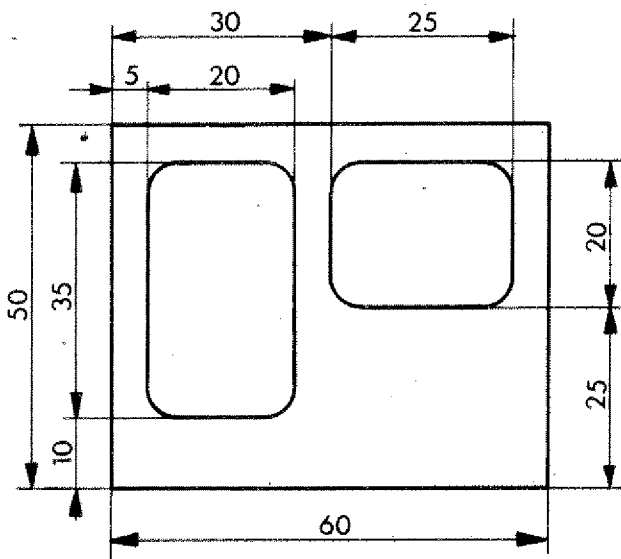
**Example:**

- Cutter diameter 8 mm
- Programming mode: incremental

Example:

- Programming mode: absolute
- Determine the zero point of the workpiece
- Mill the pockets in two runs with two subroutines, if you know G27 already.

Boring

With G00 and G01 you can execute boring operations:

1. You program with G01 (feed) at desired depth of bore
2. With rapid traverse you move to the starting point of the boring operation.

The procedure is always the same one:

- Boring with feed (G01) to length L
- Withdrawal by length L with G00.

Therefore these two movements are put together in one G-function (cycle).

G81 – Boring Cycle

Programming:

N.../G81/Z[±]...../F...

Under the Z-address you program the depth of bore.

F-address: feed in mm/min

The withdrawal is done automatically with G00.

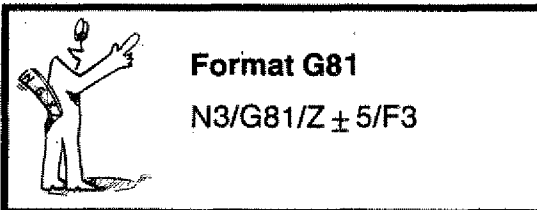
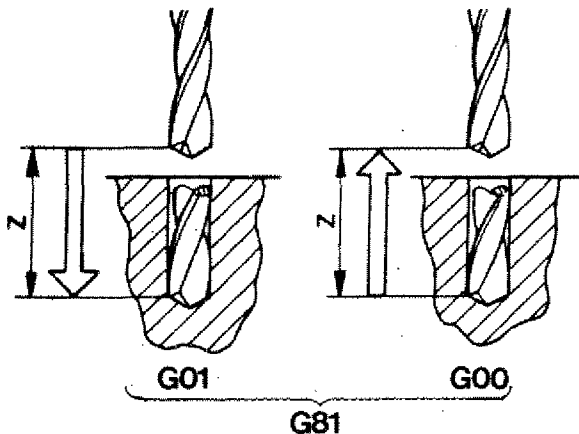

Application:

Through holes with a not too large depth of bore.

G82 – Boring Cycle with Dwell

If the depth of bore is reached, the withdrawal with G81 starts immediately (rapid traverse). The bore chip is torn off. - The surface at the base of the hole is not clean.

Therefore the drill bit remains in the programmed position Z.

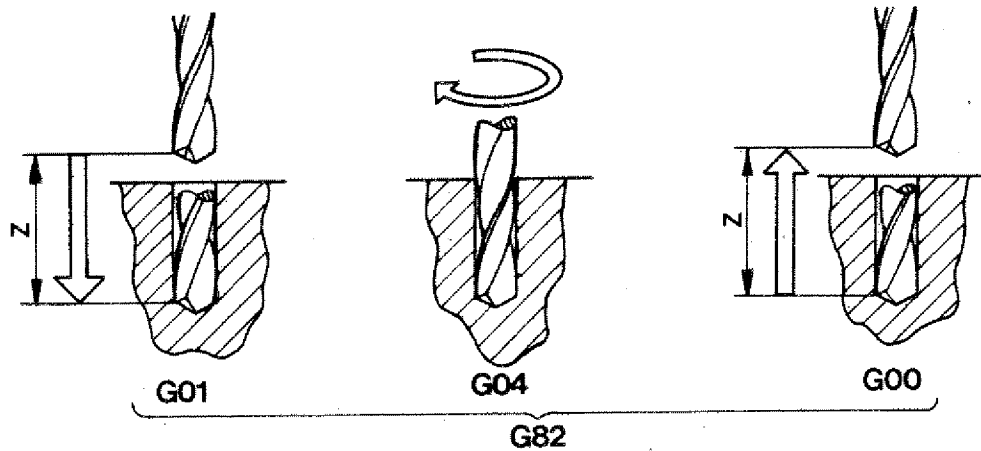

Sequence

1. First movement: with feed
2. If depth of bore is reached, the drill bit turns without feed 0,5 seconds.
3. Withdrawal in rapid traverse.

Programming:

N.../G82/Z[±]...../F...

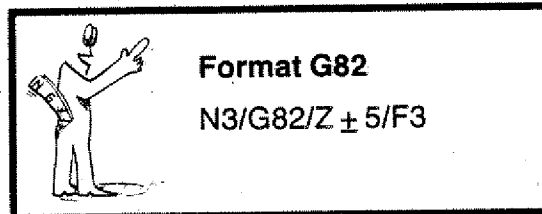

Application:

Blind holes of medium depth.

G83 – Withdrawal Cycle

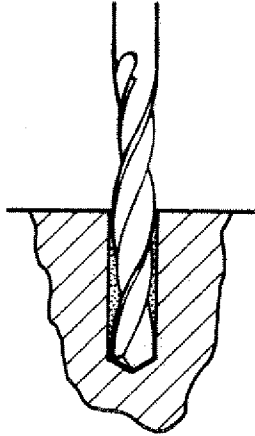

- It happens quite often with deep bores that the chips are not flowing out properly.
- Therefore you have to withdraw the drill bit in order to take away the chips.

You can program the operation with G01/G00/G01/G00 etc. or with various G81 or G82 cycles.

The drawing illustrates the principle, that a few cycles are again put together to a new cycle.

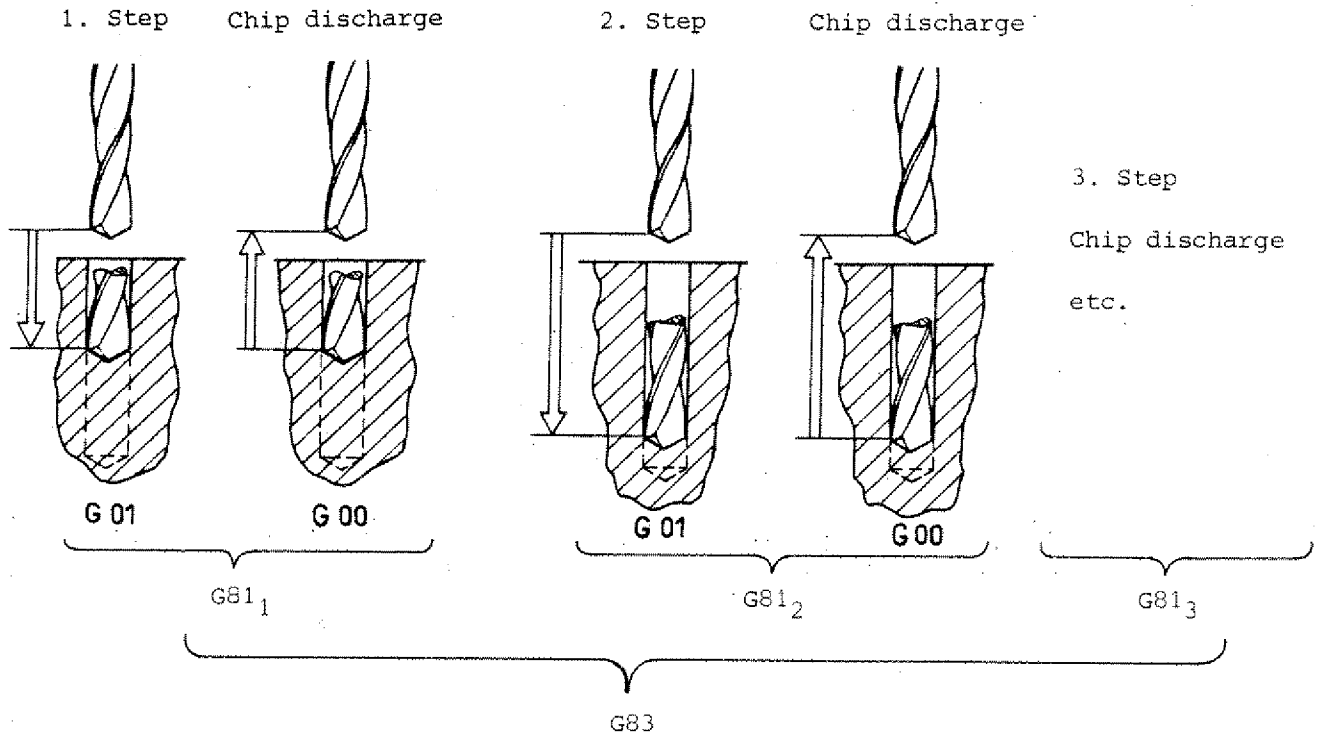

Programming G83:

N.../G83/Z[±]...../F...

The final depth of bore and the feed are to be programmed.

Procedure:

1. Bore at 6 mm depth with feed
2. Withdrawal with rapid traverse (6 mm)
3. With rapid traverse 5,5 mm and 6 mm feed
4. Go to starting point with rapid traverse
5. With rapid traverse 11 mm, with feed 6 mm etc. until you reach the programmed Z-value.

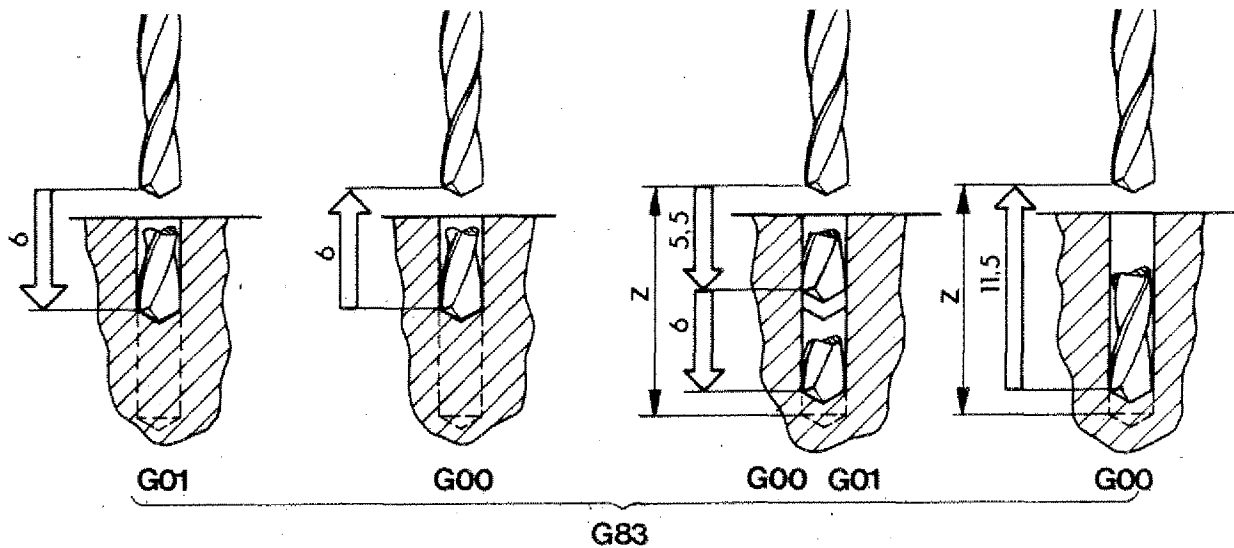
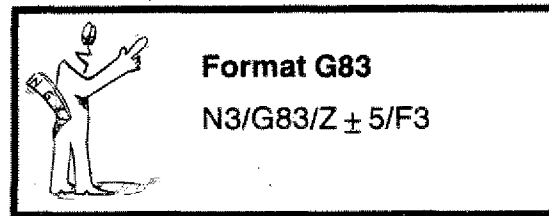

Application: Deeper bores

Example:

Pay attention to the technological data.
Use drilling emulsion to protect the drill bit.
Bores larger than 10 mm dia. need to be rough-drilled.

Use G81, G82, G83.

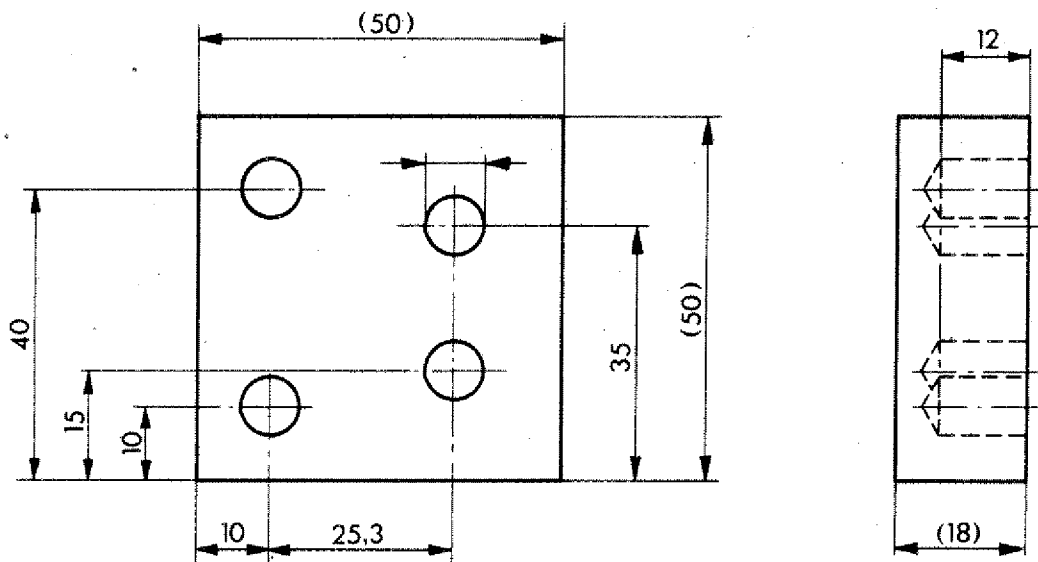

G85 – Reaming Cycle

In order to achieve bores with a high surface quality, reaming of bores is necessary.

Using standard twist drill you may reach quality 11 to 12. For higher quality standards the bores have to be reamed. By reaming you reach quality 6.

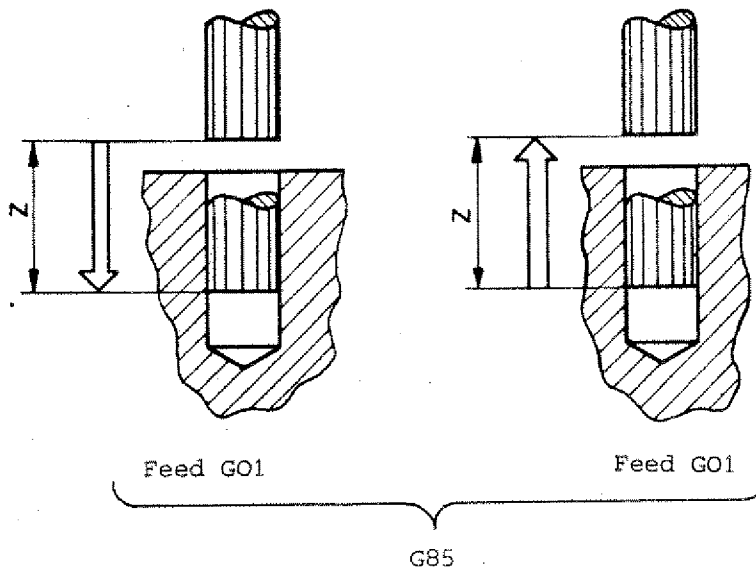

G85 is a combination of two G01 commands.

Programming:

- Block number
- G85
- Z-value
- Feed F

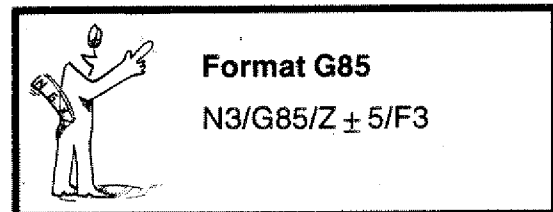
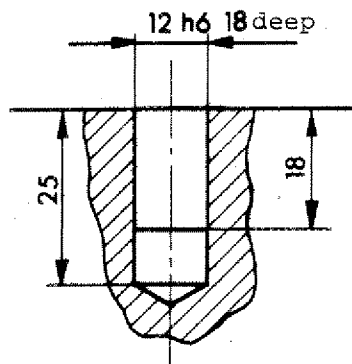

Note:

The depth of the bores to be reamed is indicated in the technical drawing. The bore-length 25 has a tolerance measurement.

G 89 – Reaming Cycle with Dwell

The sequence is the same as with G85. The reamer bit remains 0,5 seconds in the dead position if the programmed depth is reached.

Sequence

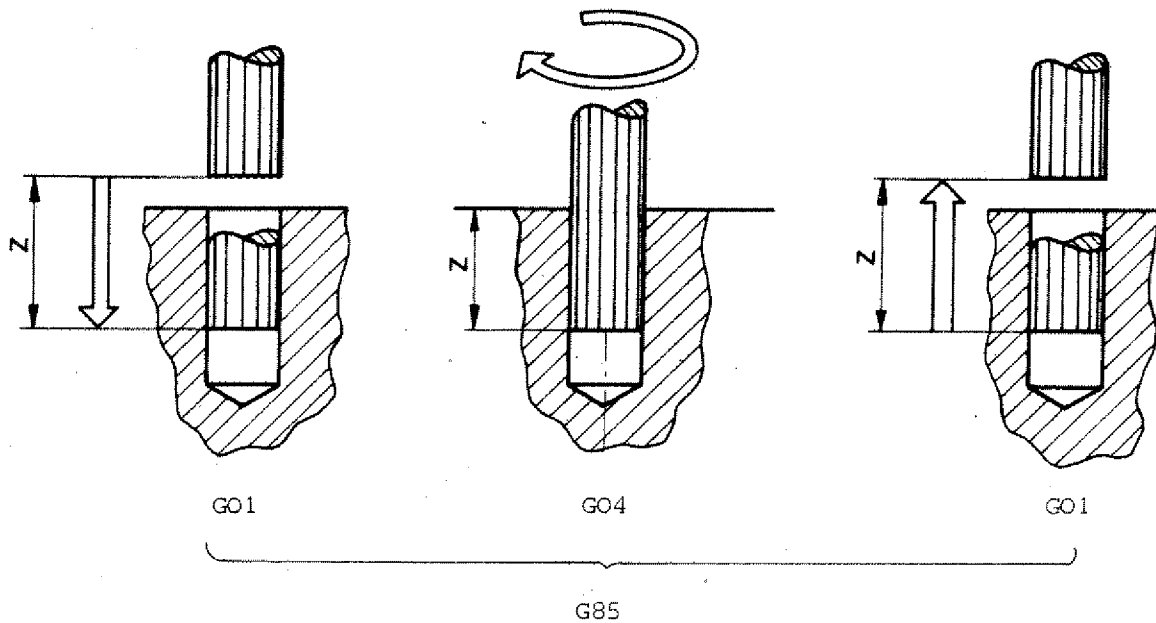

Infeed with feed at length Z

0,5 seconds dwell

Withdrawal with feed at length Z

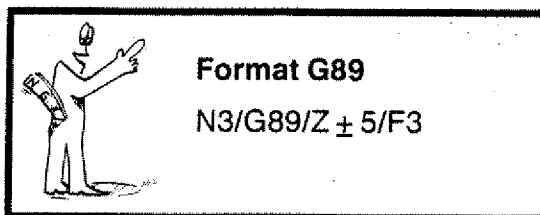

Chapter 6

Tools, tool lengths compensation,
radius compensation of milling cutter

Programming of tools	6.1
Tool lengths compensation (principle)	6.3
Working with various tools	6.5
1. Determining the tool sequence	6.7
2. Determination of tool data	
2.1. Diameter, technological data	6.7
2.2. Detecting the tool length differences	6.9
3. Calculation of tool lengths	6.13
4. Tool lengths compensation in the program sequence	6.15
5. Tool lengths corrections	6.17—6.21
Other cases for programming M06	6.23
Connection: Zero-point offset G92	
Tool lengths compensation M06	6.25
Milling of chamfers	6.27—6.33
Depth of bore with spiral drill	6.35
Tool data sheets	
Tool sheets	

The Programming of the Tools

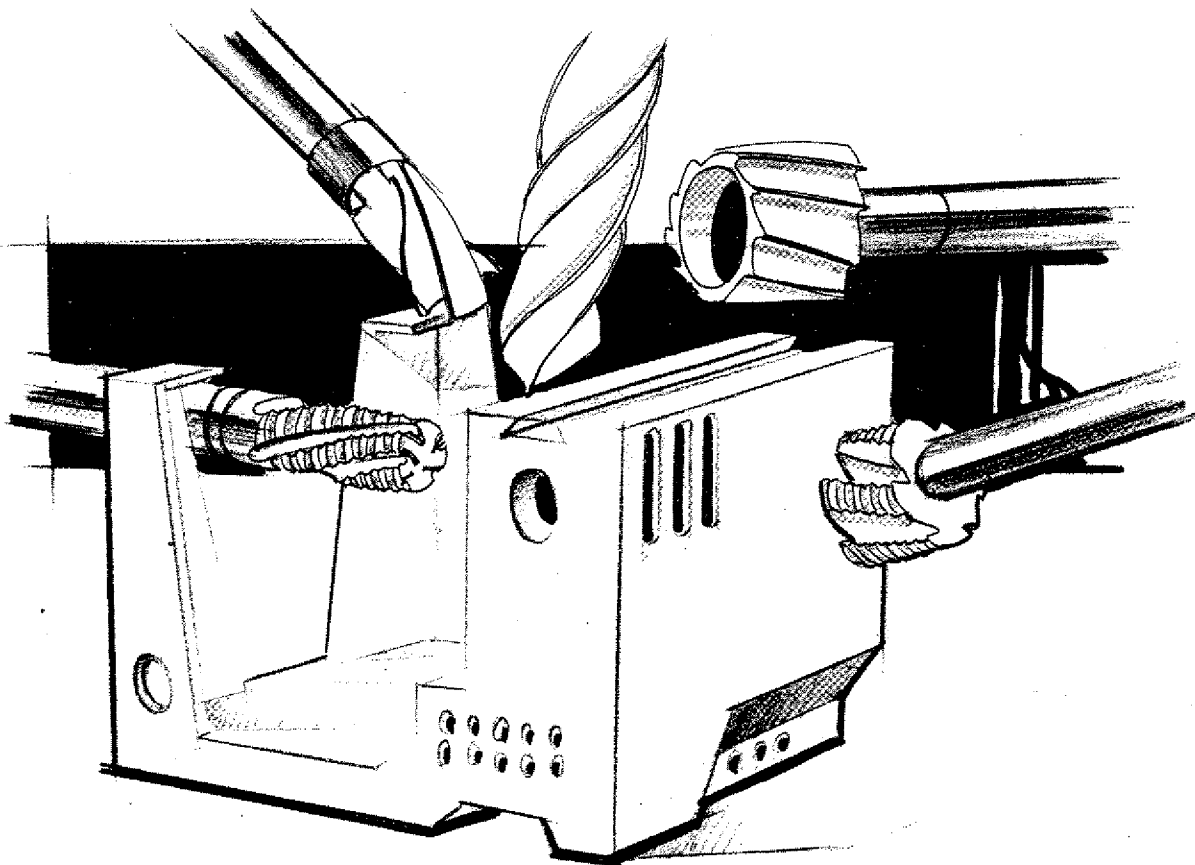

Tool magazines of industrial NC-machines
are equipped with up to 50 or more tools.

The sequence is programmed.

Technological data and dimensions have to
be programmed for each individual tool bit.

Tools are programmed using the T-address.

T stands for tool.

Tool Length Compensation

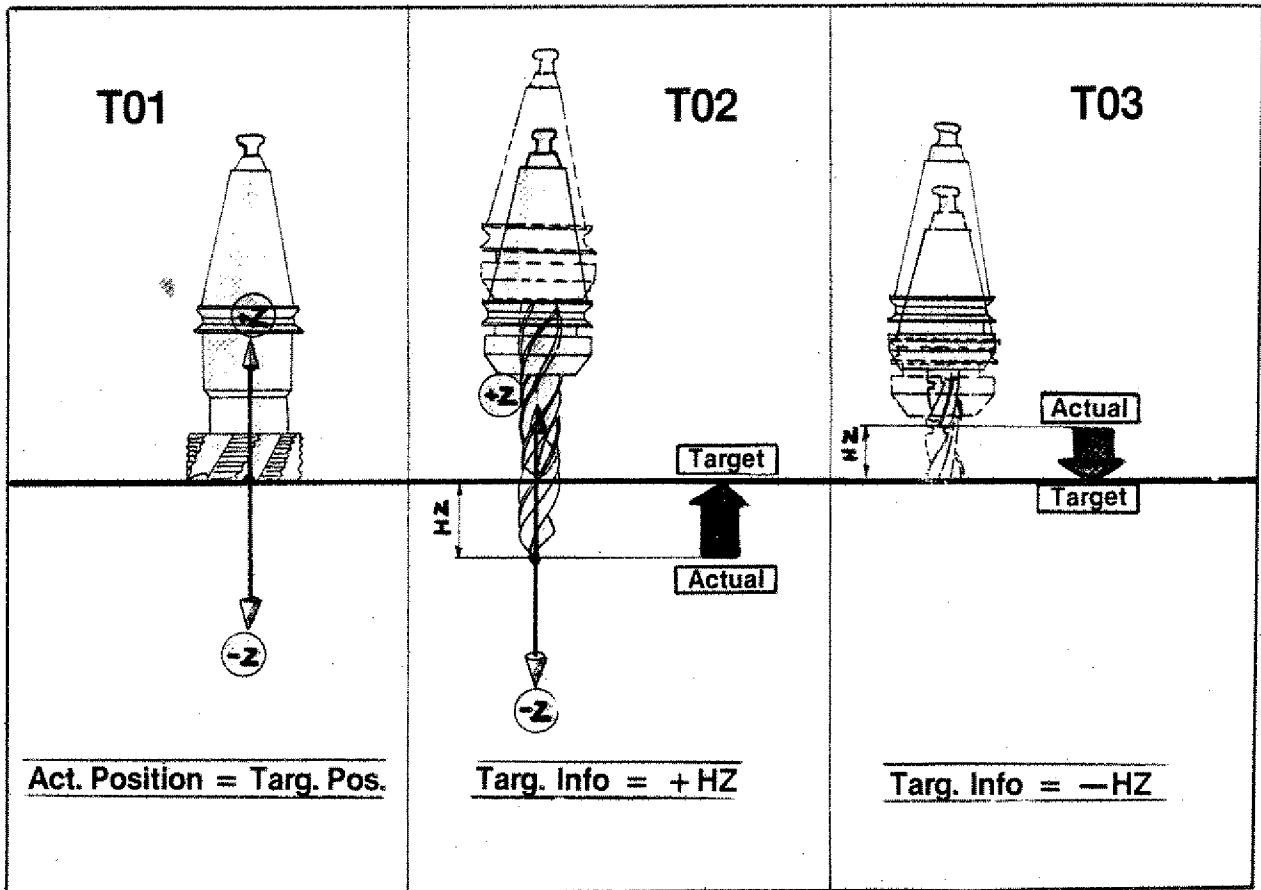

T01

M06/D..../S..../Hz=0/T01

T02

M06/D..../S..../Hz=+..../T02

T03

M06/D..../S..../Hz=-..../T03

The computer is given information on the target position or desired position.

Imagine the coordinate system transferred into the reference plane of the tool.

The target position is described starting from the actual position.

Working with various Tools

Determining the tool sequence

Detecting the tool data

Compensation of tool lengths

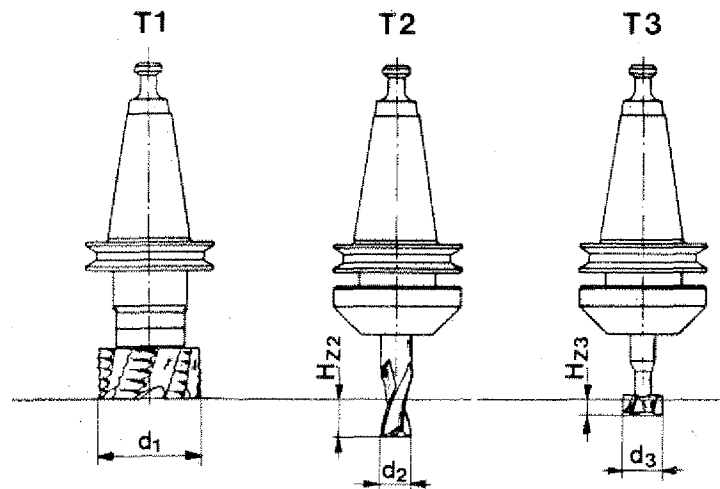

For the manufacture of a workpiece you often need different tools: drills, various milling cutters etc.

The programmer needs to know various data such as

- kinds of tools
- application of different tools,
- position of tools to each other

1. The milling cutters are of different diameters. These are known to you.
2. The tools are of different lengths. These are not known to you. You have to measure the lengths and take them into consideration when programming. Otherwise you move the cutter in the air without chip removal or you run it into a workpiece (crash).

Procedure

1. Determining the tool sequence

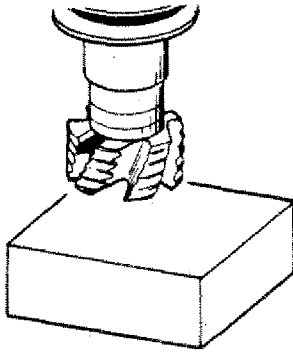

Facing with T1

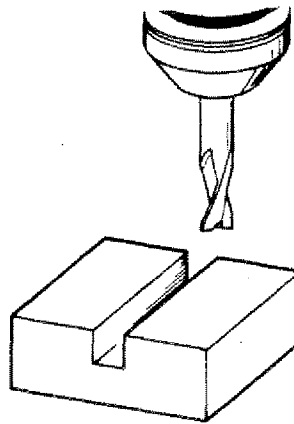

Milling a slot with T2

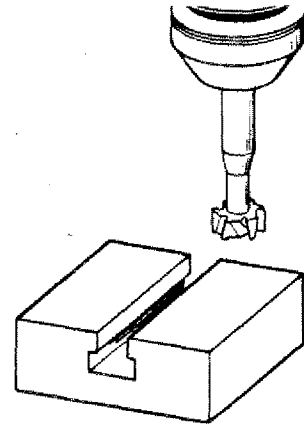

Milling a T-slot with T3

2. Determination of tool data

2.1. Diameter, technological data

	T1	T2	T3	T4
d	←	←	←	
$D = \frac{d}{2}$	←	←	←	
F	←	←	←	
t	←	←	←	
S	←	←	←	
HZ				
HZK				

Entering the data

1. Stick the tools into the corresponding column.

2. Enter the technological data:

- d = Cutter diameter
- D = Cutter radius
- F = Speed of feed
- t = Maximum depth of cut
- S = Speed

These data will make the programming easier.

2.2. Detecting the Tool Length Differences (Hz)

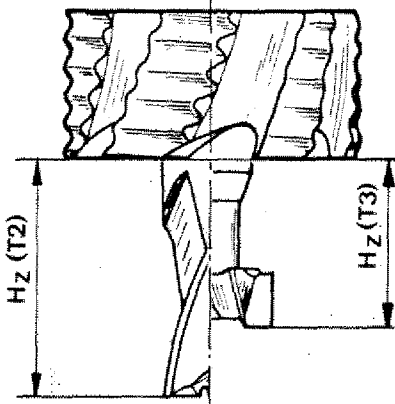

The differences in tool lengths have to be measured. The measurements can be taken using an external presetting device. In many cases the measuring system within the CNC-machine is taken use of.

You can scratch with all tools a reference surface or measure the data using a dial gauge.

The difference is called H_2 .

Procedure

Mount T1 (reference tool) and scratch reference surface, set dial gauge respectively.

Detection of data by scratching

Scratching only when cutter is turning

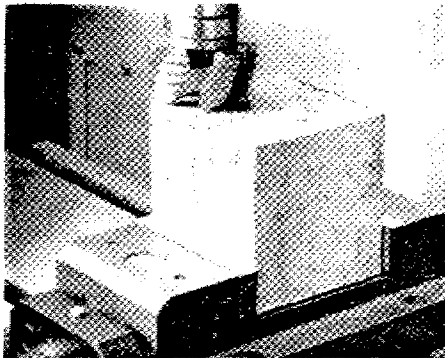

Detection of data with dial gauge.

Set dial gauge when machine is at stand-still.

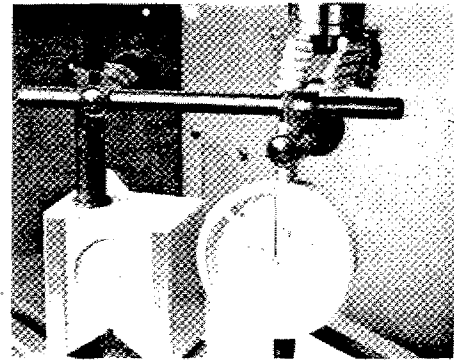

Set dial gauge to 0.

	T1	T2	T3	T4
d				
$D = \frac{d}{2}$				
F				
t				
S				
HZ	0			
HZK				

Press key **DEL**, the Z-value display is set to 0.

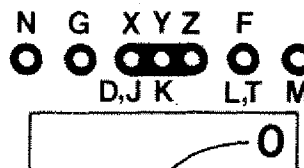

Mount T2

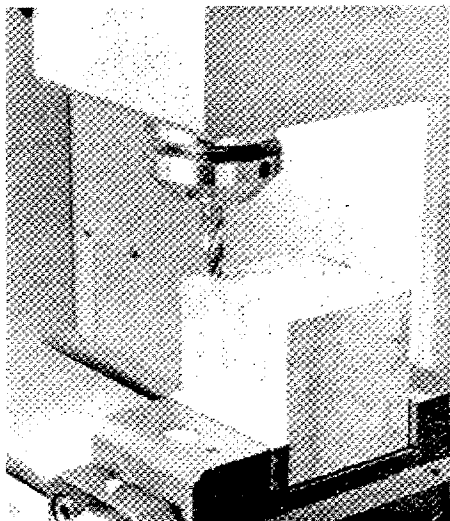

Scratch surface

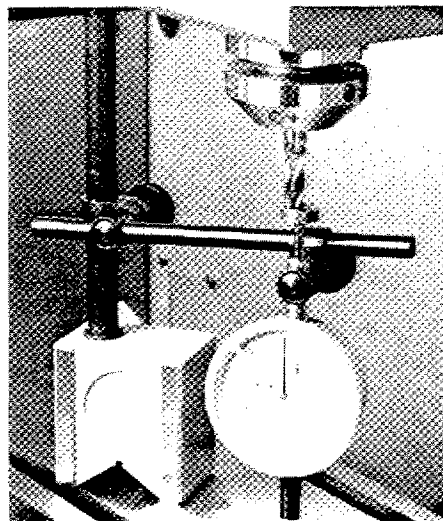

Touch dial gauge with cutter until it shows 0.

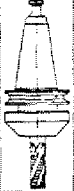
	T1	T2	T3	T4
d				
$D = \frac{d}{2}$				
F				
t				
S				
HZ	0	650		
HZK				

Read value from display.

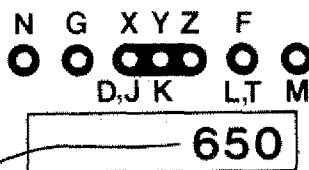

Enter value into tool data sheet. In this way you determine all tool lengths.

Pay attention to the signs!

3. Calculation of Tool Lengths (Tool lengths compensation)

Since these data are known you could take the various lengths into consideration. This would, however, be quite confusing calculation work and will often lead to mistakes.

Calculation of tool length M06 (Tool lengths compensation) (Programming)



Format M6
N3/M06/D(X)5/S4/Z(Hz) ± 5/T(F)3

The data are entered into the programming sheet.

- T = tool number
- D = milling cutter radius
- S = spindle speed (only for your information)
- H₂ = difference in tool length

N	G (M)	X (J) (D)	Y (K) (S)	Z	F (L) (T) (H)
N...	M06	2000	1100	0	1
N...	M06	500	2000	650	2

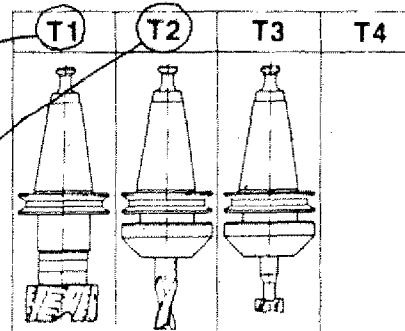

	T1	T2	T3	T4
d	40	10	16	
D = $\frac{d}{2}$	20	5	8	
F	80	160	40	
t	0,7	5	8	
S	1100	2000	2000	
HZ	0	650	-320	
HZK				

Note:

If you write a number 1,2,3,4 under the F(T) address when programming M06, this automatically means program hold.
If there is a 0 under the F(T) address, there will be no hold.

Tool Length Compensation in the Program Sequence

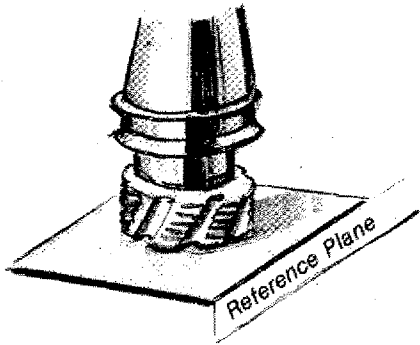

The first tool (T01) has a H_z value = 0.

N.../M06/D2000/S1300/Z(H_z) = 0/T01

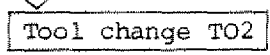
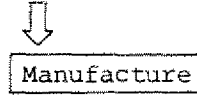

N.../M06/D500/S2000/Z(H_z) = 800/T02

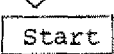

First the tool T02 moves from the actual position to the target position.

Then the manufacture itself starts.

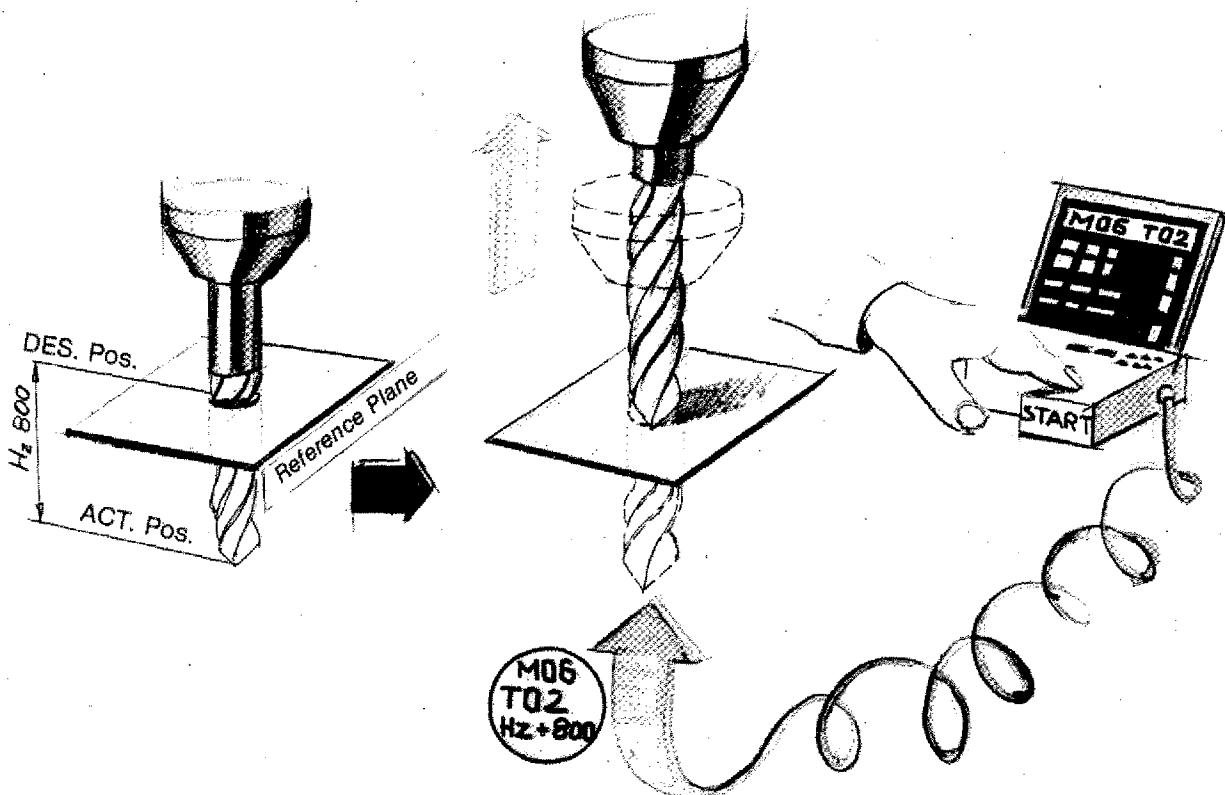

Tool Length Corrections

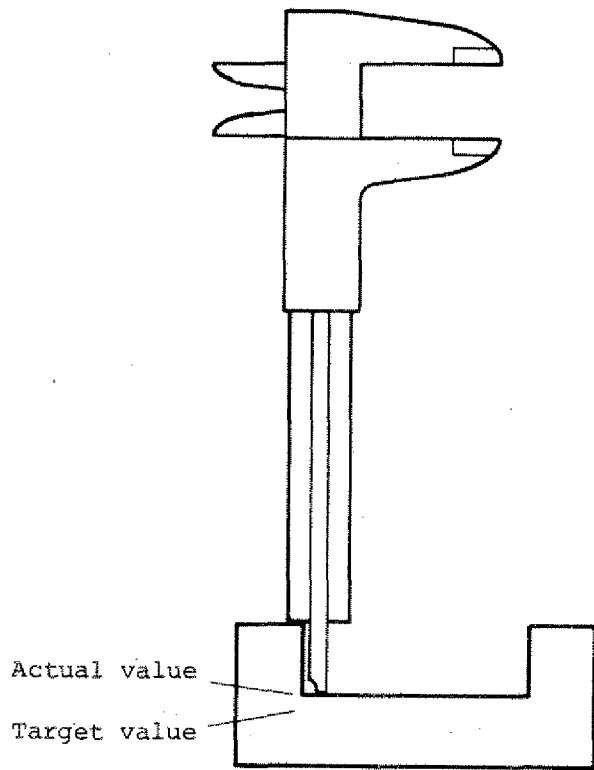

You have finished the manufacture of a workpiece and find out that the Z-measurement is not correct.

- The program is correct
- The starting position of the cutter is correct.

What is the reason?

The target value information (H_z value) was not correct (wrong, inaccurate measurements, cutter not resharpened).

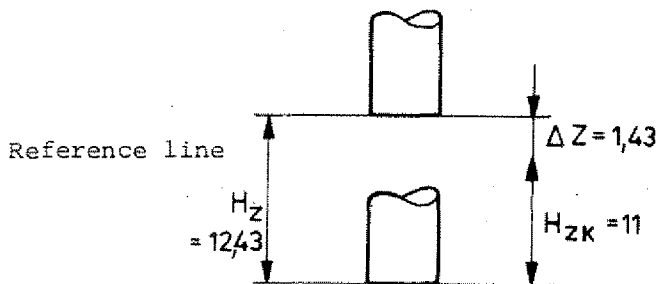

TARGET INFORMATION H_z wrong

MO6/D.../S.../Z+ 12.43/T02

The target information H_z has to be corrected.

$H_{zk} =$ Corrected target information

$H_{zk} = H_z + (\pm \text{ correction value } \Delta Z)$

MO6/D.../S.../Z+ 1100/T02

Example of a Correction of the Hz-value

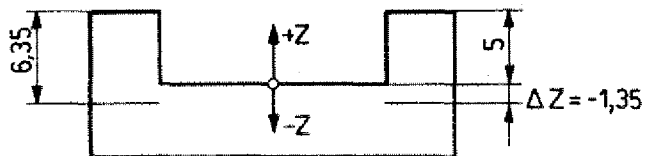

You may

1. Measure tool once again
2. Detect the correction value by measuring the workpiece.

The Hz information has to be corrected by the ΔZ value.

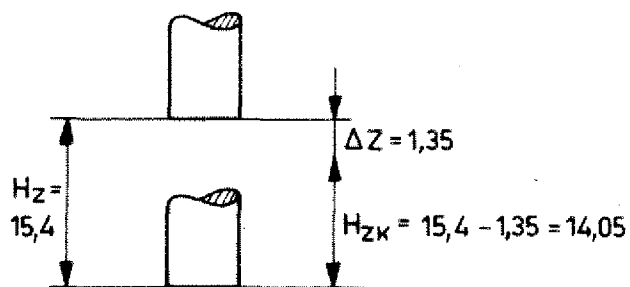

- Imagine the coordinate system transferred to the Z-actual position of the workpiece.
- Add the correction value ΔZ to the target information Hz of the tool bit.

Pay attention: ΔZ may have \pm sign.

$$\begin{aligned}
 H_{zk} &= H_z + (\pm \Delta Z) \\
 &= 15,4 + (- \Delta Z) \\
 &= 15,4 - 1,35 \\
 &= 14,05
 \end{aligned}$$

The value $H_{zk} = 14,05$ is corrected in the programming sheet, tool data sheet and in the memory.

Example

Programmed Hz-value (actual information):
- 6,25 mm

Workpiece measurements: Actual and target, compare drawing.

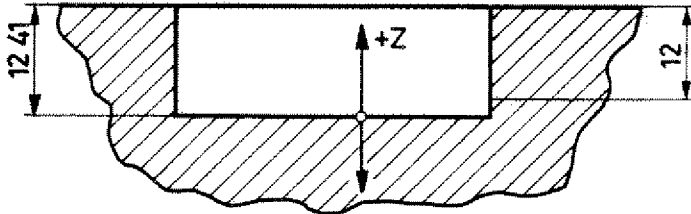

Correct the Hz-value

$$Hz_k = Hz + (\pm \Delta z)$$

Pay attention to the sign of Δz .

Hzk =

Example

Hz of TO1 = 0

Hz of TO2 = -4,32

Workpiece:

Actual value TO1 = 10,5 mm

Actual value TO2 = 5,2 mm

Target value TO1 = 10 mm

Target value TO2 = 6 mm

Correct the Hz-values of TO1 and TO2.

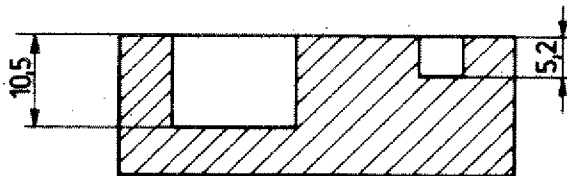
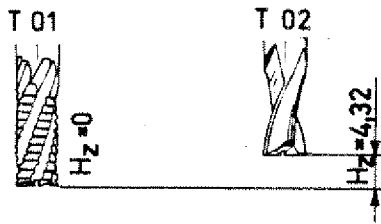

	TO1	TO2
Hzk		

Other Cases for Programming M06

N	G (M)	X (J) (D)	Y (K) (S)	Z	F (L) (T) (H)
	M06	D 500			
	G46				

If a G45, G46, G47, G48 or a G72 command (cutter radius compensation) is programmed, in one of the previous blocks a M06 has to be put in, otherwise the alarm sign will appear.
 A16: Cutter radius information missing

The computer needs the cutter radius information D in order to calculate the compensated paths (G45, G46, G47, G48)

The same applies with the pocket milling cycle G72.

Alarm A16
 Cutter radius information missing.

Connection:
G92 Zero-point offset
M06 Tool lengths compensation

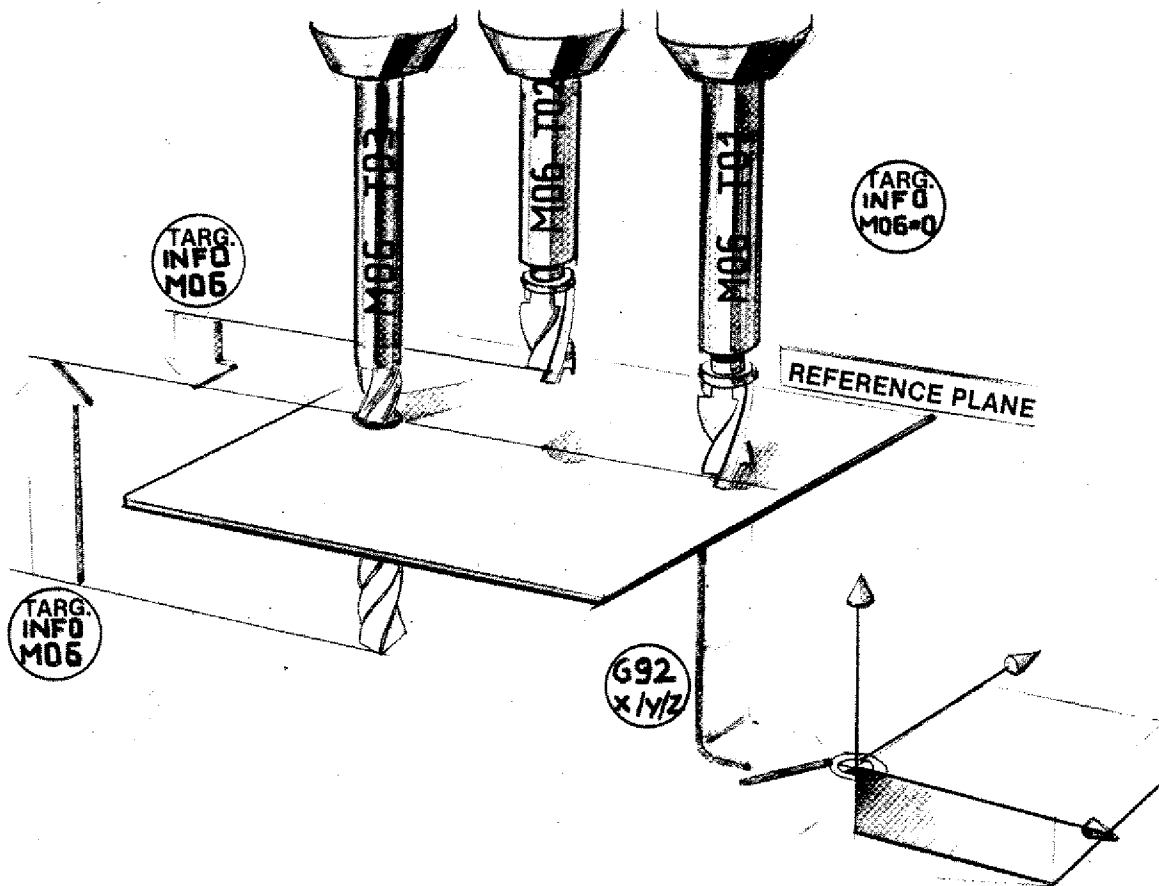

M06

The Hz-information is an incremental target information within an independent coordinate system.

G92

The origin of the coordinate system is determined with G92.

Milling of Chamfers

Chamfers are usually milled at an angle of 45° .

The size of the chamfer is determined by the programmed path and/or by the cutting contour.

1. Chamfer size determined by different cutter paths (different distances between cutter axis and workpiece edge)

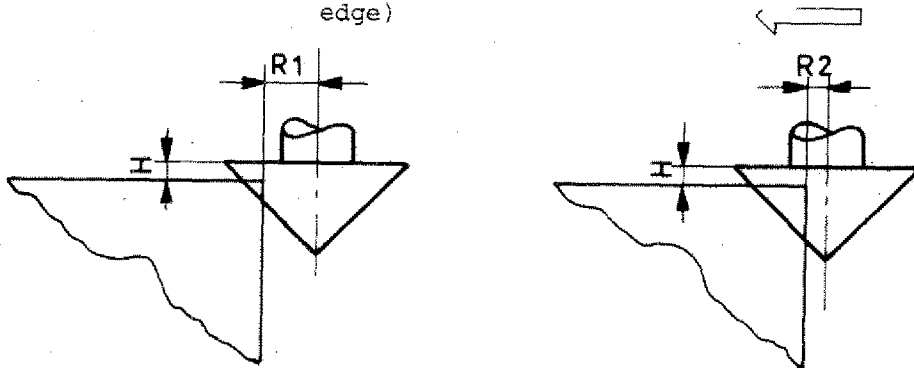

2. Chamfer size determined by different infeed and Z-direction. The cutter path remains unchanged.

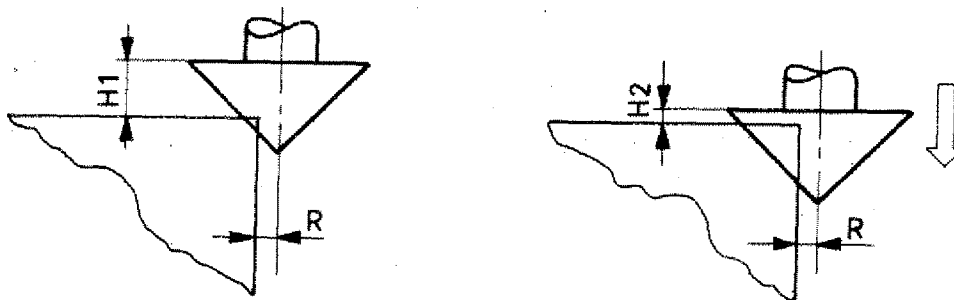

Programming a Chamfer with Cutter Path unchanged

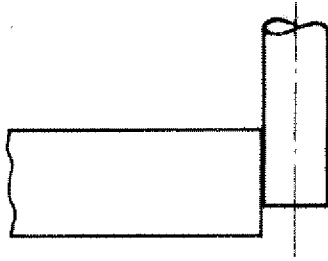

The contour is milled with a cutter of 10 mm dia.
 To avoid the necessity to program a new cutter path for chamfering, the angle cutter shall be programmed in Z-direction such that a chamfer 1x1 mm is reached.

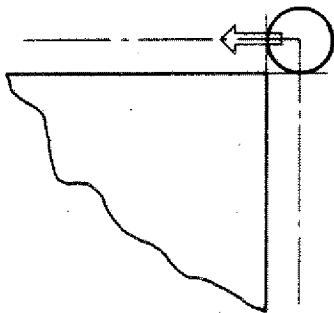

Cutter path - end mill
 =
 Cutter path - angle cutter

How deep has the Angle Cutter to be fed in?

The radius of the angle cutter which mills the inside contour of the chamfer:

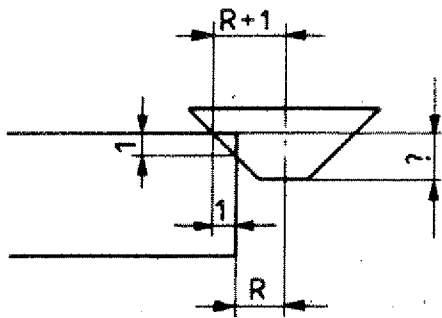

Radius end mill

+

Width of chamfer

With a mill path using a 5 mm shank, dia. 6 mm, the radius of the angle cutter produces the chamfer 1x45°.

$$\begin{array}{r}
 R \\
 | \\
 \text{Angle} \\
 \text{cutter}
 \end{array}
 =
 \begin{array}{r}
 5 \\
 | \\
 \text{Mill} \\
 \text{path}
 \end{array}
 +
 \begin{array}{r}
 1 \\
 | \\
 \text{Width of} \\
 \text{chamfer}
 \end{array}$$

Angle cutter, dia. 16 x 4 mm

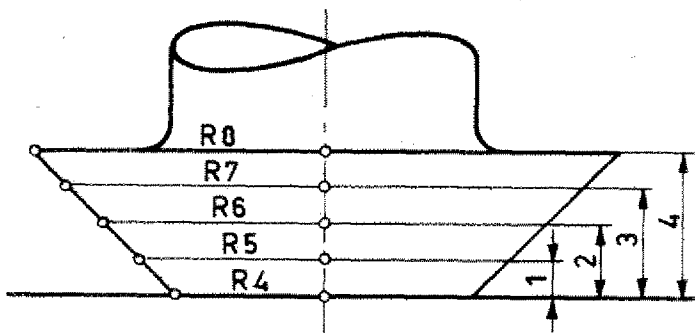

With a 45° angle cutter, the cutting radius changes by one mm if the cutter is fed in by 1 mm.

Example

Radius of mill path 5 mm

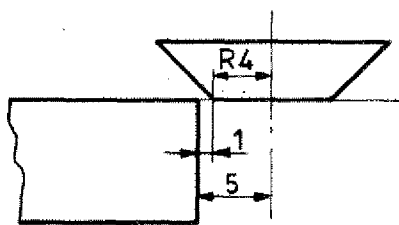

1. Cutter at height 0

Distance to workpiece = 1 mm

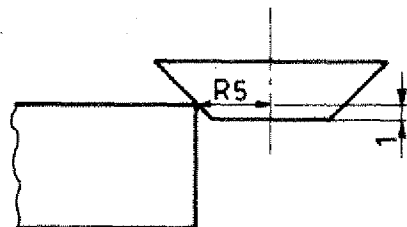

2. Cutter fed in by 1 mm

Radius 5 mm touches edge.

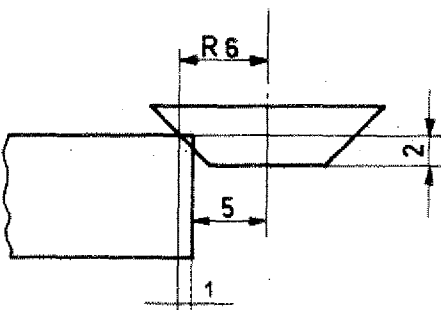

3. Cutter fed in by 2 mm

Chamfer 1x45° is produced.

Measure of total depth:

Measure until radius mill path (1 mm)

+

Width of chamfer (1 mm)

= 2 mm

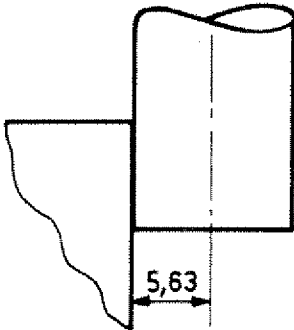

Example

Unchanged mill path

- Radius end mill: 5,63 mm
- Chamfer 0,67 x 0,67 mm

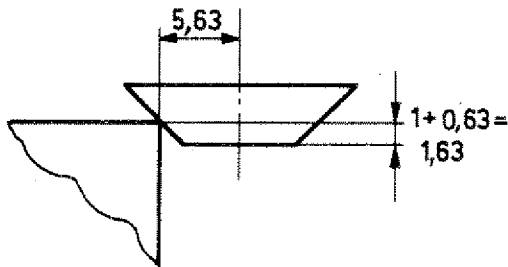

With an infeed of 1,63 mm the angle cutter touches the contour.

- Infeed 1 mm R5
- Infeed 1,63 mm R5,63

Radius 6,3 mm produces the chamfer contour.

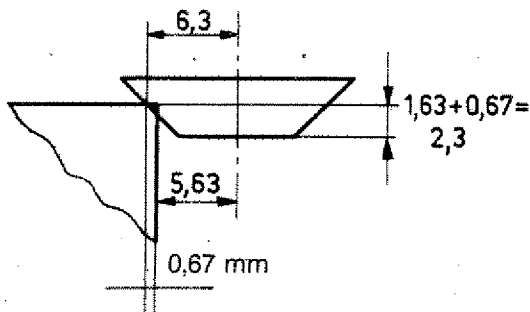

- 5,63 mm radius cutter path
- + 0,67 mm width of chamfer
- 6,30 mm

Cutter infeed

- 1,63 mm (radius touches contour)
- 0,67 mm (width of chamfer)
- 2,30 mm total infeed

The Depth of Bore with Spiral Drill

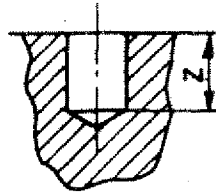

Blind holes are dimensioned down to the flat ground of the bore.

If you want to calculate the tool length you either scratch the surface with the point of the drill bit or you take measurement of the length of the tool.

In order to program the indicated depth of bore you have to add the length of the tool point.

$$\text{tg}30^\circ = \frac{H}{\frac{d}{2}}$$

$$H = \text{tg}30^\circ \times \frac{d}{2}$$

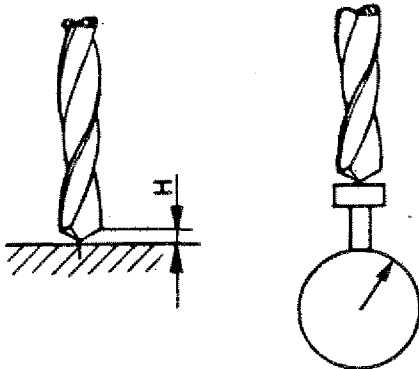

Chart

Drill dia. in mm	H (mm)
2	0.57
4	1.15
6	1.73
8	2.30
10	2.89
12	3.46
14	4.04
16	4.61

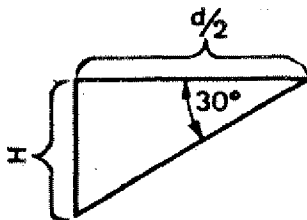
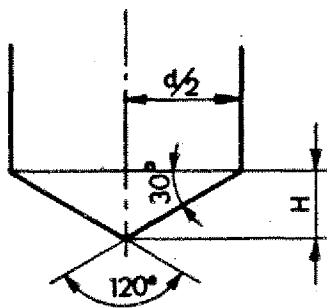

Drill Data for the Tool Sheet

Always deduct value H from the measured data when you enter it. You need not to calculate anymore and can program the dimensions of the drawing directly.

Tool Data Sheet

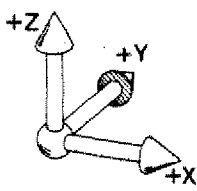
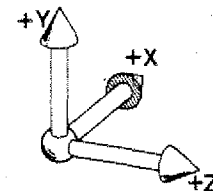
	T1	T2	T3	T4	T5	T6	T7	T8
d								
D = $\frac{d}{2}$								
F								
t								
S								
HZ								
HZK								
<p>d..... (mm)..... Cutter dia. D..... (mm)..... Cutter radius F..... (mm/min)..... Feed speed t..... (mm)..... Max. milling depth S..... (U/min)..... Spindle speed Hz..... (mm)..... Difference measure Hz_K..... (mm)..... Corrected difference measure</p>					<div style="display: flex; justify-content: space-around;"> <div style="text-align: center;"> <p>Vertical axis system</p>  </div> <div style="text-align: center;"> <p>Horizontal axis system</p>  </div> </div>			
<p>Zero-point of workpiece Start position Tool change position</p>					<p style="text-align: center;">Zero-point offset (G92)</p> <p>X _____ mm</p> <p>Y _____ mm</p> <p>Z _____ mm</p>			
					<p>Drawing no.:</p> <p>Denomination:</p> <p>Workpiece material:</p> <p>Program no.</p> <p>Name:</p> <p>Date:</p>			

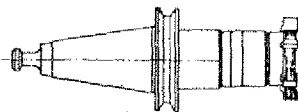
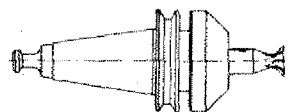
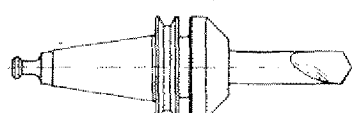
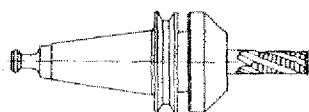
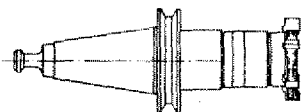
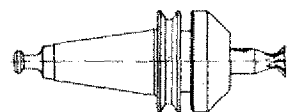
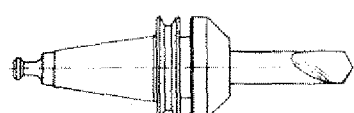
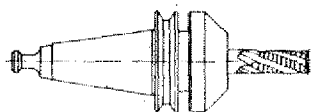
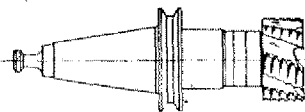
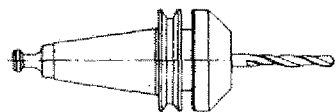
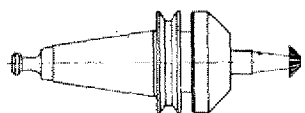
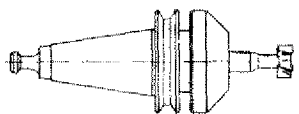
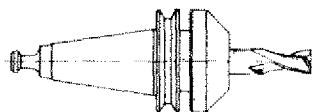
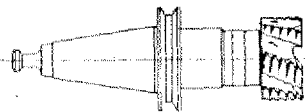
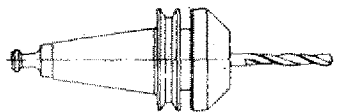
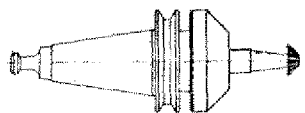
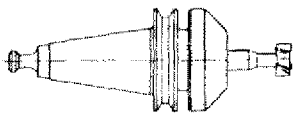
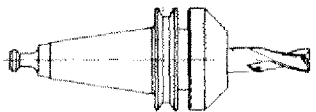

Chapter 7

The M-Functions

The M-Functions

Miscellaneous or switching functions.

M00 – Program Hold



Format M00
N3/M00

N	G (M)	X (J,D)	Y (K,S)	Z	F (T)
⋮					
⋮					
⋮					
...	M00	Halt			

If you program M00 in a block, then the program will be interrupted.

Continuation of the program: press **START** key.

When Do We Program M00?

- Tool change
- Take measurements
- Switch to hand operation
- Carry out corrections etc.

M30 – Program End



Format M30
N3/M30

N	G (M)	X (J,D)	Y (K,S)	Z	F (T)
000					
120	M30				

In the last block of a program you have to program M30. Otherwise the alarm sign A05 will appear.

After M30 the program jumps automatically to N00. You can start anew.

If the DNC interface is mounted, M30 switches off the main spindle (M03 is cancelled).

M03 – Milling Spindle on
 (only with accessory DNC-Interface)

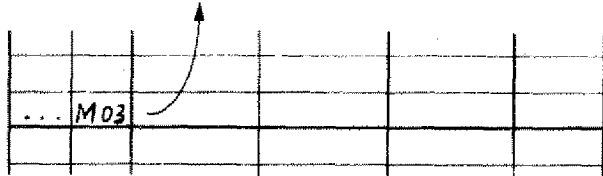
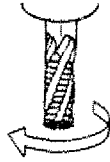



Format M03
N3/M03

The M03 instruction switches on the milling spindle. Switch the milling spindle on such that the motor has enough time to run up and that you are in position to set the right rpm.

Important note M03

Before pushing the start key the main spindle switch has to be set to CNC-position.

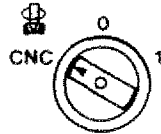

M05 – Milling Spindle Off

(only with accessory DNC-Interface)

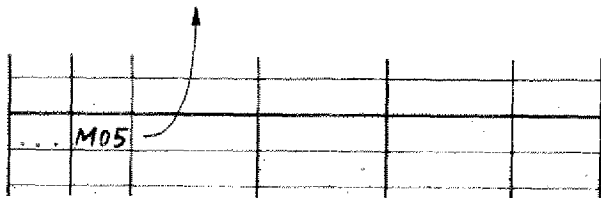



Format M05
N3/M05

When do we program M05?

- Before a tool change
- Before taking measurements

Note:

M30 switches off the milling spindle too.

M06 switches off the milling spindle if T(F) ≠ 0.

M06 – Tool Lengths Compensation

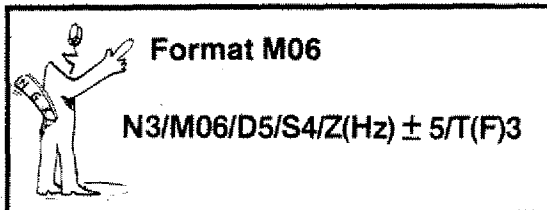

Compare chapter "Tool Lengths Compensation"

M17 – Jump Back Into Main Program

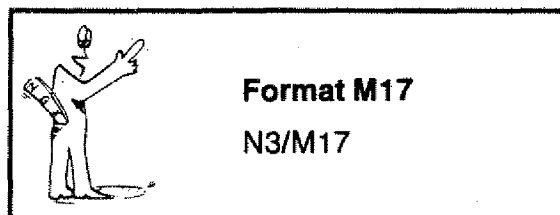

Compare "Subroutines"

M99 – Circle Parameter

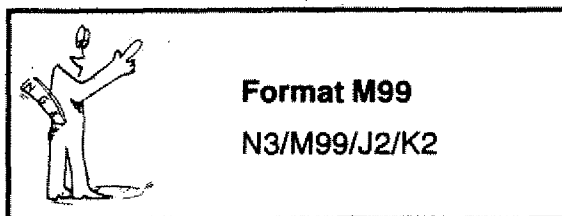

Compare "Circle Programming"

**M08, M09, M20, M21, M23, M26 are
as switching functions not yet defined.**

With them you could activate peripheral
devices (under preparation!)

Chapter 8

Input of Program, Corrections, Operation

Survey	8.1
What happens when data is put in?	8.2—8.3
Input format	8.4
Indication on the screen	8.5
Input of program	8.6—8.7
Operating elements CNC; Program input	8.9
Option key hand operation — CNC operation	8.9
The word indication	8.10
The figure keys, the minus key	8.12
The memory key INP	8.13
The → key	8.14
The FWD key	8.15
The REV key	8.16
The DEL key	8.17
Input of M-values	8.18
Take-over of registered values	8.19
Inserting and deleting of blocks	8.20
Deleting of a registered program	8.21
Program Sequence	8.23
Testrun	8.25
Single block operation	8.26—8.27
Automatic operation	8.29
Interventions during program flow	8.31—8.33
— Program stop	
— Program hold	

Input of Program Corrections Operation

The knobs, displays, symbols, etc. will confuse you in the beginning. So first put in the very simple programs and check the various function keys. In half an hour you will be accustomed to them.

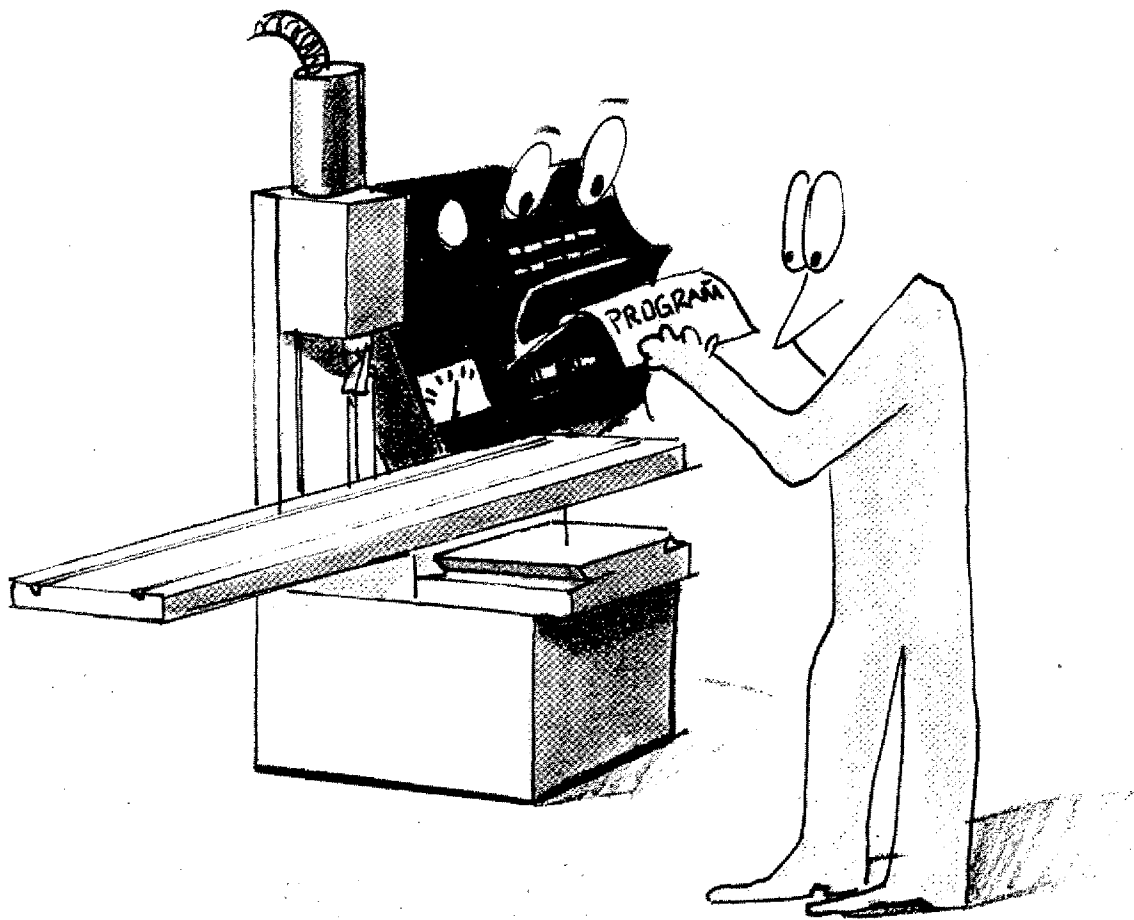

Survey

Data Input, Correction, Delete

Storing a word

INP

Take over of values

Correcting a word

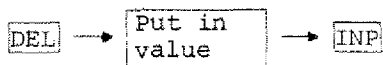

M-programming

Press **M**

Searching a word

→

Searching a block

FWD **REV**

Inserting a block

~ + **INP**

Deleting a block

~ + **DEL**

Deleting a program

DEL + **INP**

(first DEL)

Set program to NOO

INP + **REV**

Sequence of Program

Testrun:

Inching through the program with M

Single block operation

1 + **START**

2 +

3 +

⋮

(first number key)

Automatic operation

START

Influencing the Program

Termination

INP + **REV**

Interruption

INP + **FWD**

Storing of Program

Compare tape operation
RS-232 C operation

What happens when Data is put in?

We put in GO1.

1. Secretary (interface element) reports to director:

"Somebody wants GO1!"

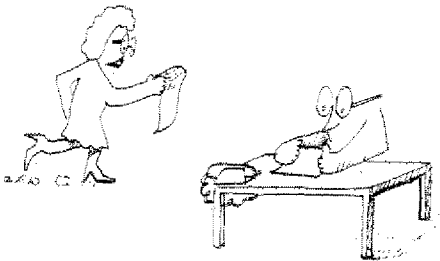

2. Director (CPU = Central Processing Unit = Microprocessor) asks his specialists:

"Can we execute GO1?"

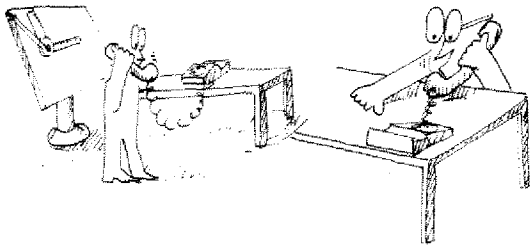

3. The specialists (EPROM = Programmable read-only memory) think and inform the director:

"Yes we can!"

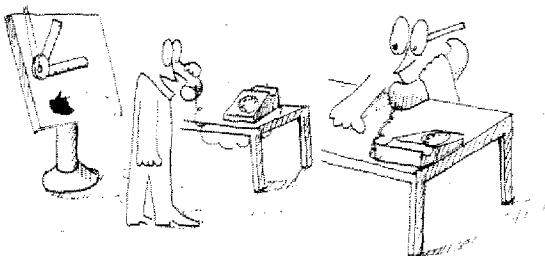

4. The director instructs the memory operating program (RAM = Random access memory):

"Remember GO1!"

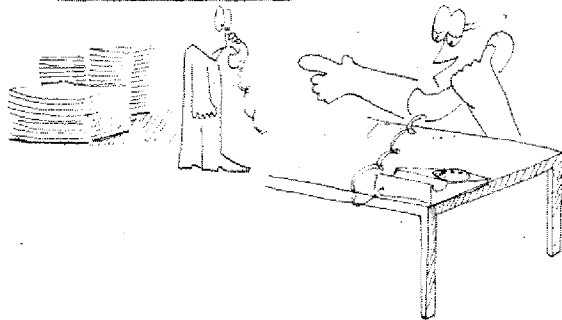

5. The memory reports to the director:

"O.k., I have noted it down!"

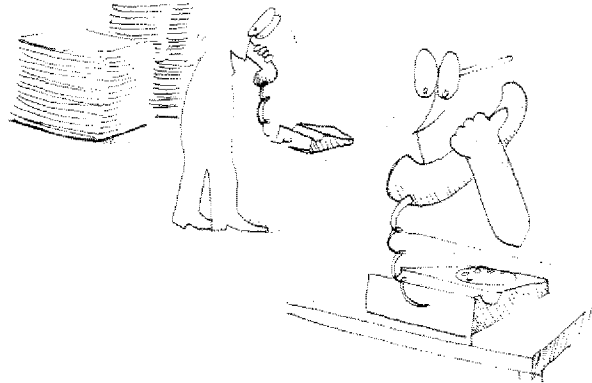

6. Director instructs his press-speaker (output element):

"Show them out there, that we are clear with GO1. We have everything understood and are ready for further inputs!"



What happens when Data is put in?

Data Input

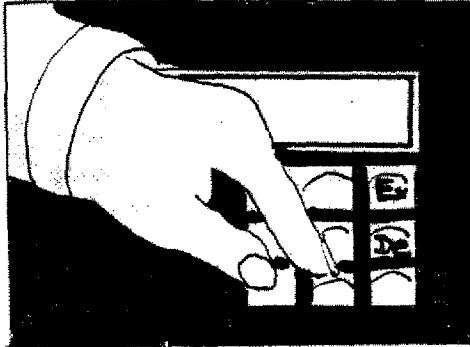

Digital read-out

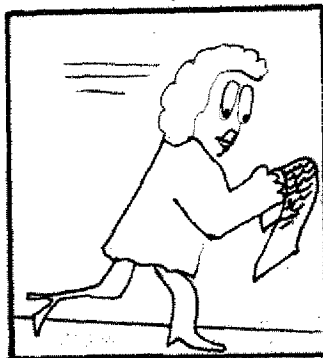

Interface element
(secretary)

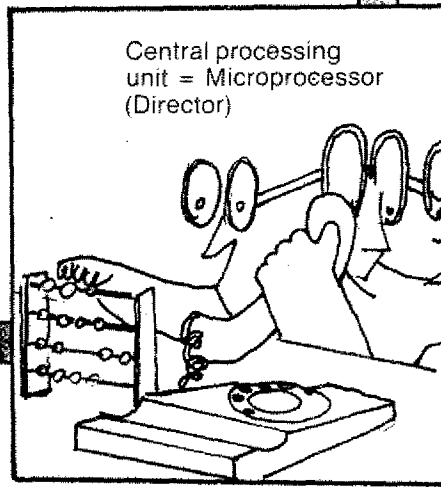

Central processing
unit = Microprocessor
(Director)

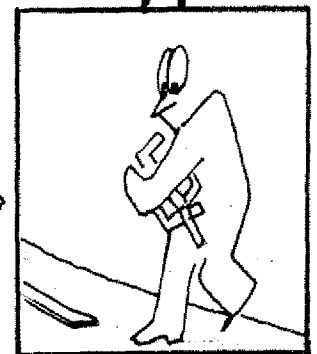

Output element
(press speaker)

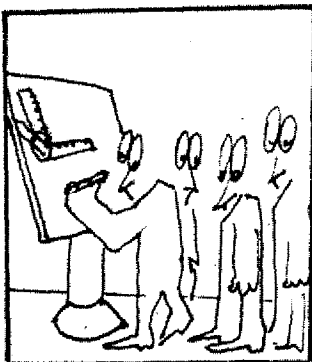

Operating program =
EPROMS (Specialists)

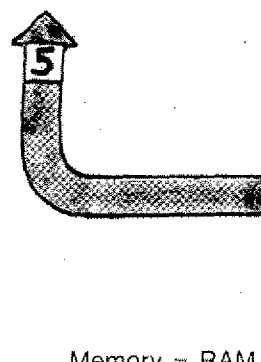

Memory = RAM

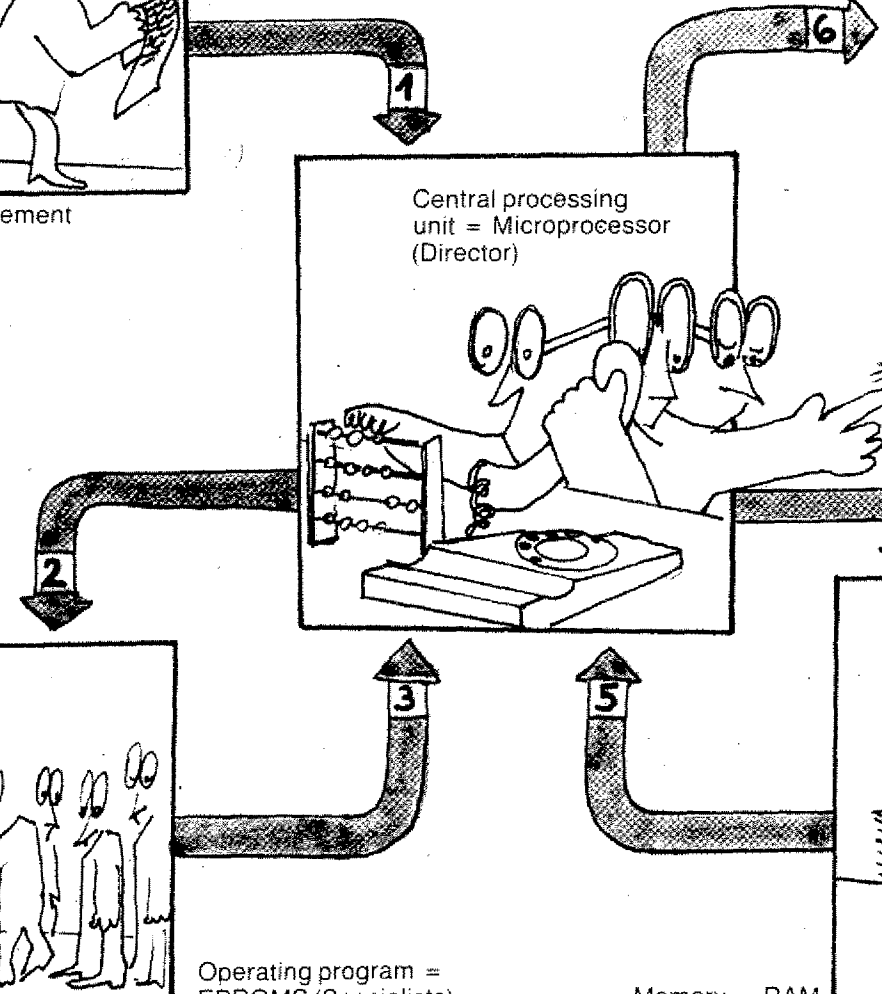

The Block Format or Input Format

According to the key number (G-, M-functions) you have to put in the required information.

The computer will ask these informations.

N	G (M)	X (J) (D)	Y (K) (S)	Z	F (L) (T) (H)
06	G90				
07					

INP

Example:

If you press INP after the G90 input, the indication jumps to the next block number.

N	G (M)	X (J) (D)	Y (K) (S)	Z	F (L) (T) (H)
00	G00	235	432		
01					

Example:

You have entered the X,Y-values with G00. After the registration of the Y-value the indication jumps to the next block number.

Why?

The computer knows that it can interpolate only in two planes. After input of X- and Y-values it sets the Z-value automatically to 0 (with incremental programming).

N	G (M)	X (J) (D)	Y (K) (S)	Z	F (L) (T) (H)
00	G00	0	400		

Example:

If you, however, have programmed the X-value with zero, the computer will ask for a Z-value.

N	G (M)	X (J) (D)	Y (K) (S)	Z	F (L) (T) (H)
00	G00				

Example:

With absolute programming mode the computer asks all three values X,Y,Z.

You have to tell the computer the plane from which it has to start the movements.

Indication on the Screen

```
CNC OPERATION   INCR.  
| N | G | X | Y | Z | F |
```

```
CNC OPERATION   ABS.  
| N | G | X | Y | Z | F |
```

Mode of operation absolute – incremental:

1. When switching on the CNC-operation the control is in incremental operating mode.
2. If you program G90 or G92 the screen shows the absolute operating mode.
3. If you program G25 or G27 the display disappears. The computer recognizes this only in the program run.

Mode of operation metric – inch:

According to the position of the option switch the metric or inch mode of operation will be indicated.

Metric 0,01 mm

Inch 0,001"

```
CNC OPERATION   ABS. 0.01MM ⊥  
| N | G | X | Y | Z | F |
```

Vertical or horizontal axis system

⊥ Vertical

⊣ Horizontal

These symbols indicate which axis system is in operation.

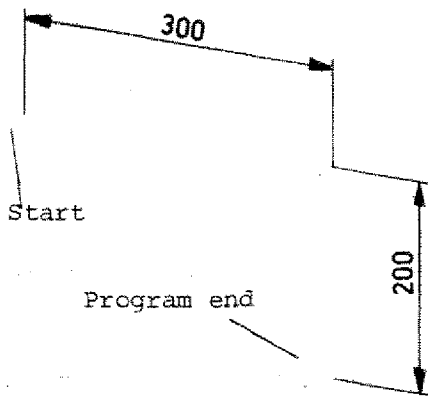

Input of program

Example

N	G (M)	X (J) (D)	Y (K) (S)	Z	F (L)(T)(H)
00	00	3000	0	0	
01	00	0	0	-2000	
02	M30				

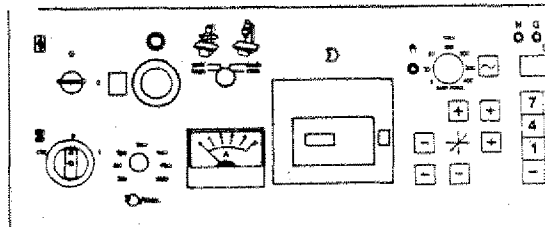

1. Switch on main switch

Control lamp for current supply and lamp for mode of operation "hand-operation" are on.

H/C

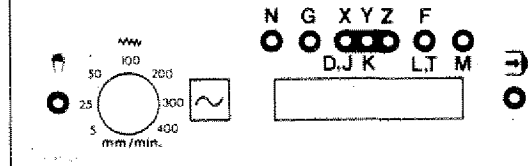

2. Press key H/C

The control unit is switched over to CNC-mode of operation. On the digital read-out the lamp of address N is on. 00 (NOO) is shown.

The screen shows N 00

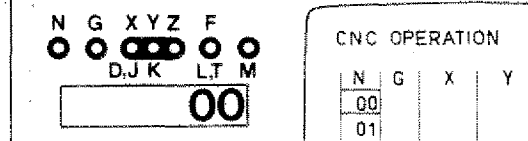

INP

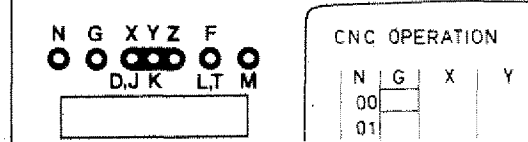

3. Press key INP

With INP you instruct the computer to register NOO. The address letter jumps to G.

0 0

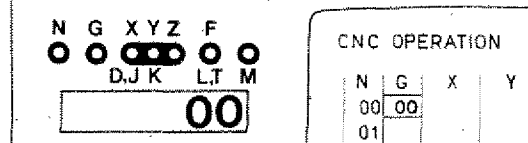

4. Put in G-information

00 shows on the digital read-out.

INP

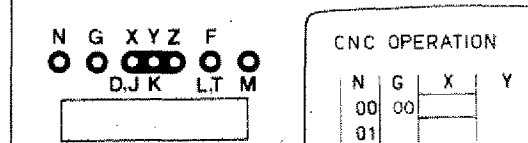

5. Press key INP Address indication jumps to X.

3 0 0 0

N G XYZ F
D.J K LT M

3000

CNC OPERATION			
N	G	X	Y
00	00	3000	
01			

6. Put in X-value 3000.

INP

N G XYZ F
D.J K LT M

CNC OPERATION			
N	G	X	Y
00	00	3000	
01			

7. Press INP. Display jumps to Y.

0

N G XYZ F
D.J K LT M

0

CNC OPERATION			
N	G	X	Y
00	00	3000	0
01			

8. Put in Y-value 0

INP

N G XYZ F
D.J K LT M

CNC OPERATION				
N	G	X	Y	Z
00	00	3000	0	
01				

9. Press INP. Display jumps to Z.

0

N G XYZ F
D.J K LT M

0

CNC OPERATION				
N	G	X	Y	Z
00	00	3000	0	0
01				

10. Put in Z-value 0.

INP

N G XYZ F
D.J K LT M

01

CNC OPERATION			
N	G	X	Y
00	00	3000	0
01			

11. Press INP. Block NO0 is entered. Block indication jumps to NO1.

12. Enter block NO1 in the same way. Put in the Minus sign after the number value.

M 3 0

N G XYZ F
D.J K LT M

30

CNC OPERATION			
N	G	X	Y
00	00	3000	0
01	00	0	0
02	M30		
03			

13. M30 (program end)

- Put in NO2
- Display is at G.
- Press key M, then the M-address is indicated.
- Put in the figure value.
- Press INP.

START

14. Press key START. Display jumps to NO0 (only if M30 is programmed).

START

15. Press key START, the program runs.

Operating Elements – CNC



Program Input

Option Key Hand-Operation/CNC-Operation

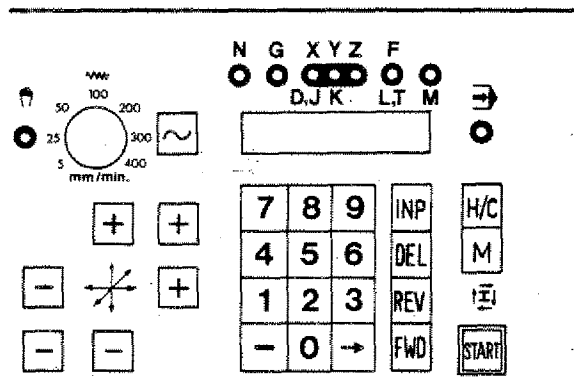
H/C



By pressing key **H/C** the mode of operation changes from "hand-operation" to "CNC-operation".

The relative mode of operation is indicated by the lamps  (CNC-operation) or  (hand-operation).

To put in a program it has to be switched to CNC-operation.

In the CNC-mode of operation you cannot move the slides by hand anymore.

The Word Indication

The lamps and light bars of the word indication show you which data you can put in.

Digital read-out

The actual words are indicated by lamps

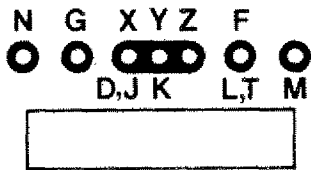

Monitor

The actual words are indicated by a light bar.

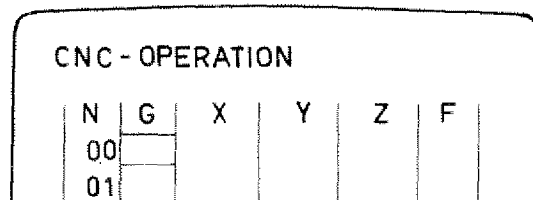

Address indication - G, M function

If depends on G or M-functions which addresses and/or data are required?

E.g. MO6
MO6 requires a D,S,Z,T information.

Digital read-out

The X-indication is also valid for the D-value, the Y-indication for the S-value and the F-indication for the T-value if MO6 was programmed.

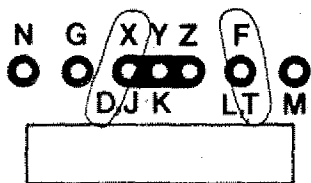

Monitor

The address letter D,S,T are indicated.

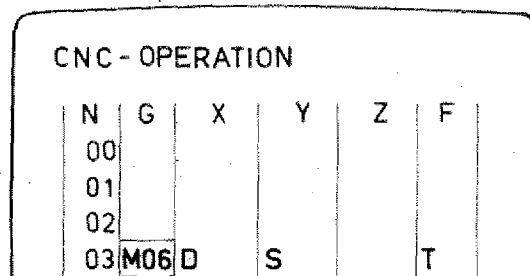

The Indication of Addresses D, J, K, L, T, M on the Screen

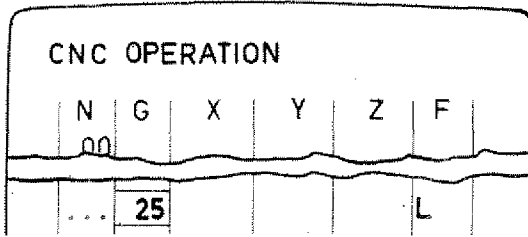

G25/G27

The address letter L is indicated.
(L = jump address, subroutine address)

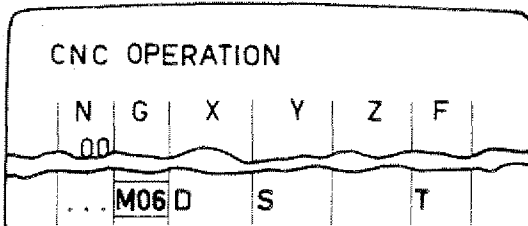

Format M06

Addresses

- D (milling cutter radius)
 - S (spindle speed)
 - T (tool number)
- are indicated.

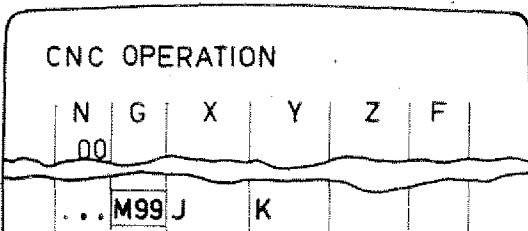

Format M99

Addresses

- J (start of arc of circle)
 - K (end of arc of circle)
- are indicated.

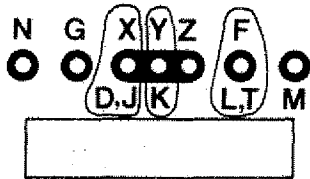

Attention:

X, Y, F lamps are valid for various addresses.

The Figure Keys

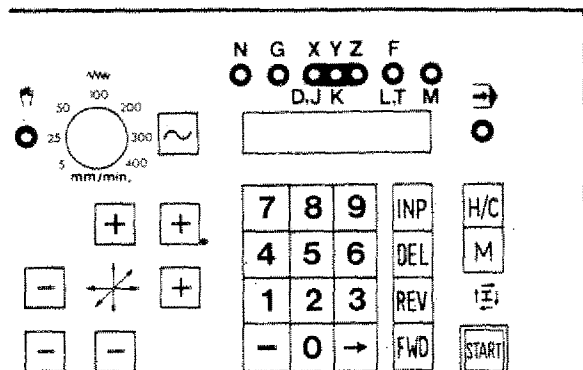

You use the figure keys in order to enter the various values for address letters X, Y, Z, F, G, M, D, T, L, J, K. The entered values appear on the digital read-out and/or on the screen of the monitor.

The Minus-Sign Key

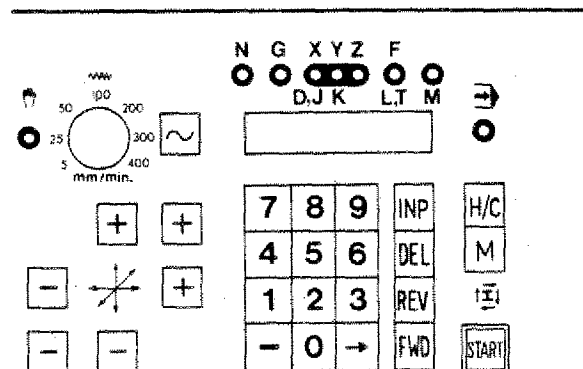

X, Y, Z values can have a minus or a plus sign.

Plus sign input for X, Y, Z:

Put in figures only.

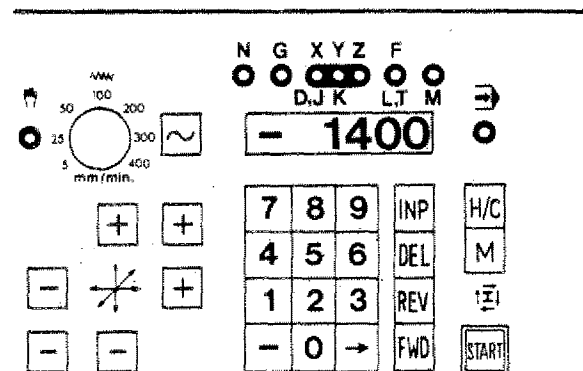

Minus sign input

After input of figures, press key. The minus sign appears as a bar on the digital read-out.

Example:

X = -1400

Input: 1400

The **INP** Key = Memory Key

INP = Abbreviation for Input

INP = Instruction to the computer to register the entered value.

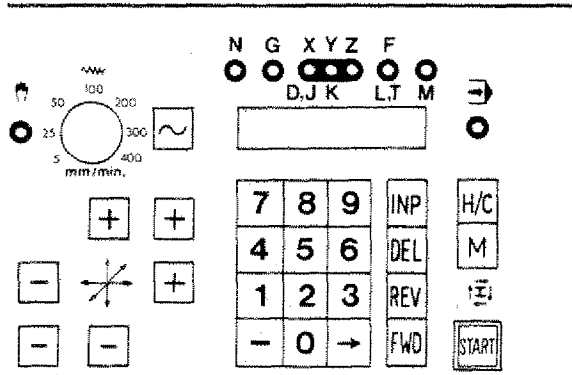

Digital read-out

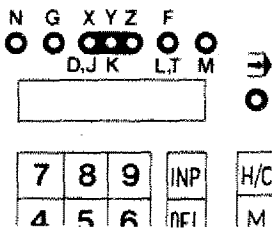

Example

- Lamp X lights up.
- Enter value **2350**. The number appears for your information only, it is not in the computer yet.
- You press **INP**. By pressing this key, figures are registered; at the same time the number 2350 disappears and the light jumps to the next address letter.

Monitor

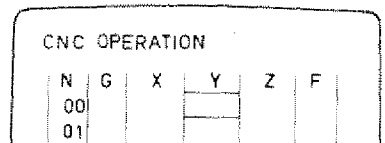
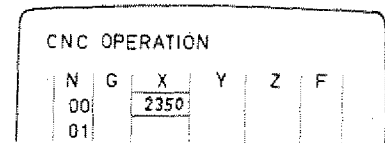



Note

With **INP** you can also jump forward in the block.

The Key

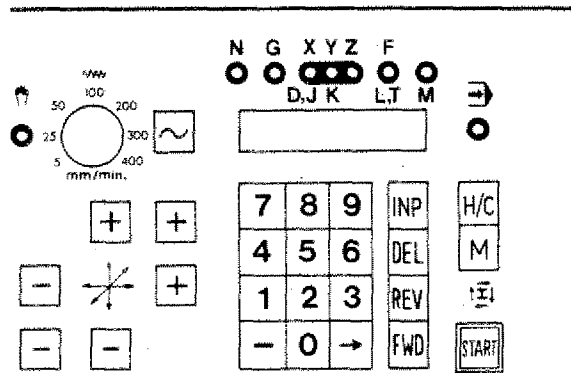
Instruction: to jump forward within one block



By pressing the key  the program will jump to the next word. The entered value of the next word will appear on the digital read-out.

(Permanent function when you keep on pressing the key)

N	G (M)	X (J) (D)	Y (K) (S)	Z	F (L) (T) (H)

The **FWD** Key

Instruction: to jump forward block-by-block

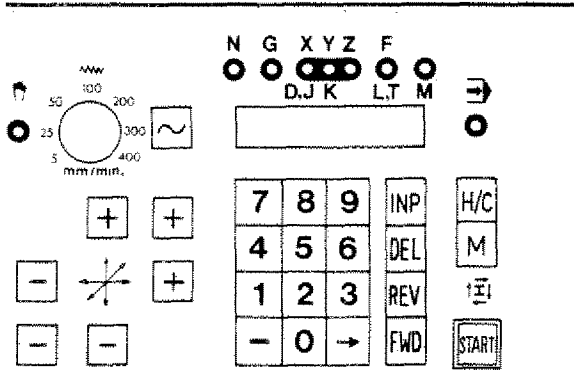

N	G (M)	X (J) (D)	Y (K) (S)	Z	F (L) (T) (H)

1. A given word is displayed. By pressing the **FWD** key the program jumps to the next block number.

N	G (M)	X (J) (D)	Y (K) (S)	Z	F (L) (T) (H)

2. If a block number is indicated: when pressing the **FWD** key the program jumps to the next block number.

N	G (M)	X (J) (D)	Y (K) (S)	Z	F (L) (T) (H)

3. If you keep the **FWD** key pressed down, the program will jump block-by-block to the program end.

The **REV** Key

Instruction: to jump back in program blocky-by-block

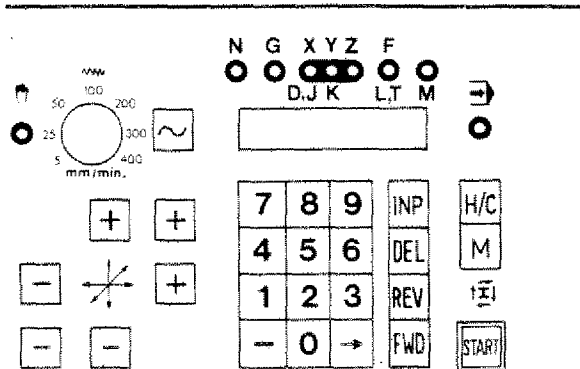

N	G (M)	X (J) (D)	Y (K) (S)	Z	F (L) (T) (H)

Function:

1. A given word is on the display.
If you press key **REV** the program jumps to block number N.

N	G (M)	X (J) (D)	Y (K) (S)	Z	F (L) (T) (H)

2. If block number N is indicated and you press key **REV**, then the program will jump to the previous block number.

N	G (M)	X (J) (D)	Y (K) (S)	Z	F (L) (T) (H)

3. If you keep the **REV** key pressed the block number jumps back to N00 (permanent function).

The **DEL** Key = Delete key, correction key

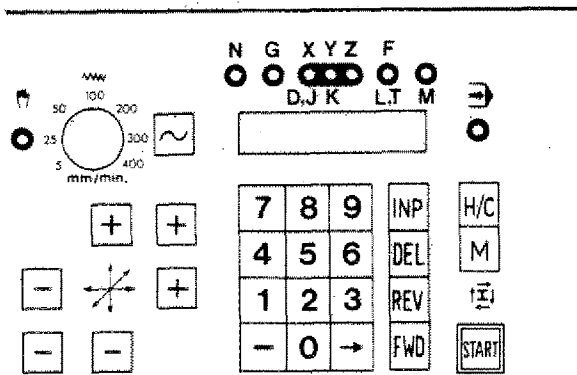

"DEL" is the abbreviation of "delete", which means to cancel, to extinguish.

You can delete only the value of the address letter which is indicated. If you correct a X-value e.g., the address letter X has to be on the digital read-out.

Attention:

With **DEL** only the digital read-out is cancelled, not the value in the register. You must put in a new value and store it with **INP**.

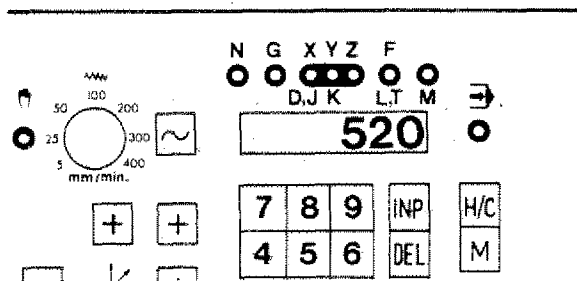

Example: You want to change value X from 520 to 250.

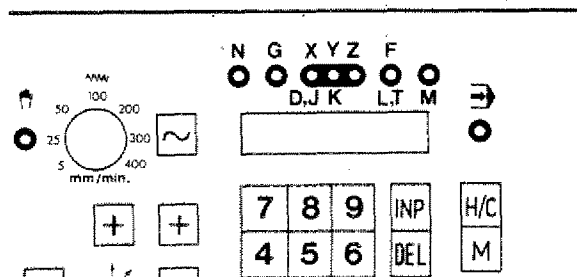

1. Press **DEL** key, the value 520 will disappear.

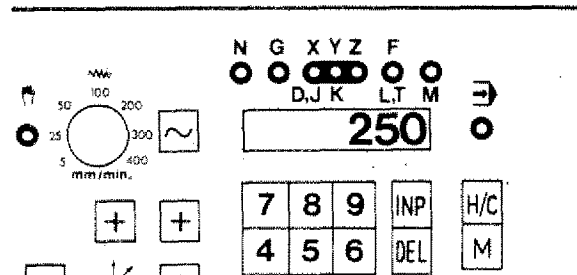

2. Put in the correct value (250).

3. Press **INP** key, value X is registered; light jumps to the next address letter.

Input of M-Values

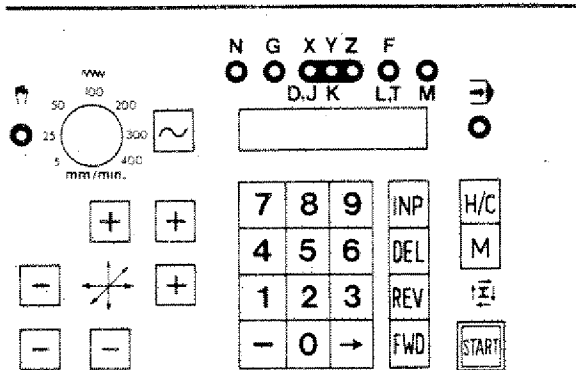

If you want to put in M-values: at first you have to select the M-key. The M-value is programmed in the G-column.

Digital read-out

Example

Monitor

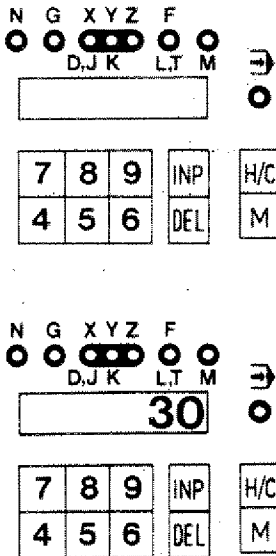

Input: M30

Address G has to be shown

Press **M**



Put in **30**



Press **INP** (register)

CNC OPERATION						
N	G	X	Y	Z	F	
00						
01						
14						

CNC OPERATION						
N	G	X	Y	Z	F	
00						
01						
14	M30					

Attention:

- + M-values are not taken over by pressing **INP**
- + If you press **INP** after M30, the program jumps back to N00.

Take-Over of registered Values into the following Blocks

By pressing **INP** the register takes over the previously entered value of the relative word column.

N	G (M)	X (J) (D)	Y (K) (S)	Z	F (L)(T)(H)
00	00	2000	3000		
01	00	0	0	-4000	
02	<input type="text"/>				
03					

INP

Example 1

- G-address is shown
- **INP**
- G-value flashes shortly and is registered
- Word indication jumps forward

N	G (M)	X (J) (D)	Y (K) (S)	Z	F (L)(T)(H)
00	00	200	3000		
01	00	0	0	-2000	-1000
02	01	2000	0	0	100
03	01	0	4000	<input type="text"/>	
04					

INP

Example 2

- You want to put in the value Z=0 in block NO3.
- You happen to see that the Z-value in block NO1 should be -1000 and correct the value.
- After correction you carry on with the Z-value input of block NO3.
- If you press **INP** the register takes over the previously entered Z-value, i.e. -1000.

Attention:

M-values and inputs are not taken over with **INP**.

Inserting and Deleting of Blocks

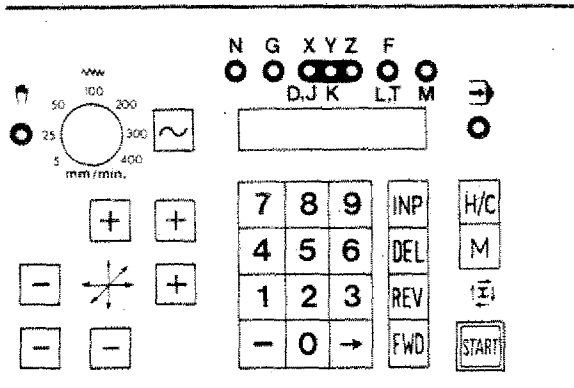

+ **INP** = Inserting a block
 + **DEL** = Deleting a block

Remark 1:

First press key and then key **INP** (keep pressed).

Remark 2:

Permanent function when you carry on pressing (more than 0,6 sec.), i.e. you insert permanently empty lines with G21.

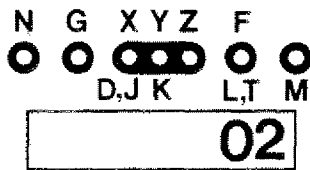

Example: Inserting + **INP**

+ Digital read-out shows block NO2.

+ Press + **INP**

+ In block NO2, G21 is automatically written.

+ The original block NO2 is automatically changed over to NO3 - also all subsequent blocks to the next block number.

+ In block NO2 you can program required instructions as you want.

N	G (M)	X (J) (D)	Y (K) (S)	Z	F (L)(T)(H)
00	00	1500	400	0	
01	01	0	0	60	100
02	01	250	0	0	100
03	00	0	0	-60	
04	M30				

+ **INP**

00	00	1500	400	0	
01	01	0	0	60	100
02	21				
03	01	250	0	0	100
04	00	0	0	-60	
05	M30				

00	00	1500	400	0	
01	01	0	0	60	100
02	01	0	120	0	100
03	01	250	0	0	100
04	00	0	0	-60	
05	M30				

Procedure

+ Delete G21

+ Put in wanted block

Example: Deleting + **DEL**

+ Digital read-out shows NO2

+ Press + **DEL**

+ NO2 is deleted

+ All subsequent blocks are backnumbered: NO3 - NO2, NO4 - NO3, etc.

Deleting of a registered Program

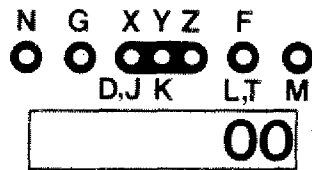
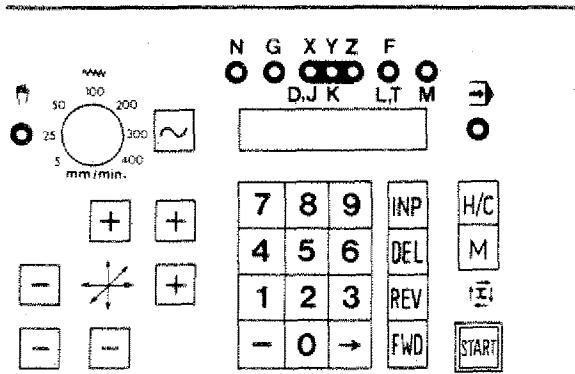

Possibility 1

Switch off main switch.

Possibility 2

Press emergency stop button.

Possibility 3

A certain block number is indicated (NOO, NO1, NO2 ...).

Procedure

First press key **DEL** then **INP** (DEL remains pressed).

The registered program is deleted.
The digital read-out shows NOO.

The Program Sequence

1. Testrun

The program runs in the computer. There are no instructions given for slide movements.

2. Single-block operation

The program is worked off block by block. The slides move as programmed.

3. Automatic operation

The total program is worked off. Switching instructions are carried out.

1) Testrun

The program runs "in the mind". The instructions for slide movements are not given.

Purpose of the testrun:

- Block mistakes are shown.
- With absolute programming mistakes of the linear or circular interpolation are indicated (e.g. if you programmed movement in 3 planes simultaneously or you determined the target point of the quadrant uncorrectly, etc.).

If you have programmed subroutines or jump instructions you can check the order of the instructions.

Activation of testrun:

1. CNC-operation
2. Indication has to be on N-address
3. Press **M**-key:
the indicated block is worked off.
4. Press **M**-key:
The following block is worked off.

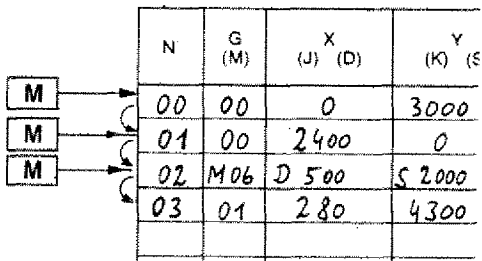

	N	G (M)	X (J) (D)	Y (K) (S)
M	00	00	0	3000
M	01	00	2400	0
M	02	M06	D 500	S 2000
	03	01	280	4300

etc.

2) Single block operation

In the testrun you do not see whether you run with e.g. G00 into the workpiece or whether \pm directions are correct. This you see in the single block- or in the automatic operation.

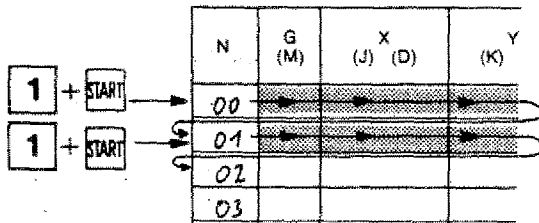

Example:

1. Block NO00

- Block indication is at NO00.



- **1** + **START**

Press key 1, then key START (key 1 has to remain pressed).



Block NO00 is worked off.

The screen shows "dwell in block NO01".

2. Block NO01

Press again **1** + **START**.



Block NO01 is worked off.



The screen shows "dwell in block NO02".

In this way the program can run in single block operation.

Single block operation

(continued)

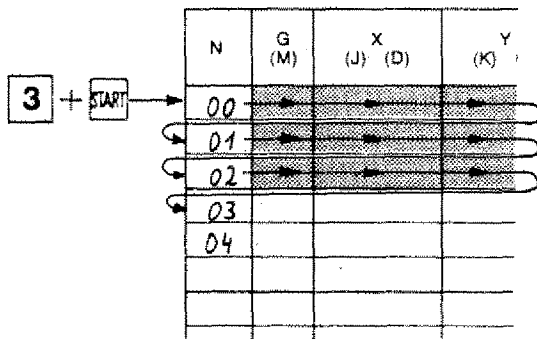

Various blocks in single block operation:

If you e.g. press keys **3** + **START**, there will be 3 blocks worked off. You can work off up to 9 blocks in one go **9** + **START**.

Dwell in single block operation

Press **INP** + **FWD**.
The slides stop.

If you press **START**, the program continues.

Interruption of program

Press **INP** + **REV**.
The program jumps back to N000.

3) Automatic operation

	N	G (M)	X (J) (D)	Y (K) (S)	Z
START	00				
	01				
	⋮				
	⋮				
START	24	M00			
	⋮				
	⋮				
	31	M30			

- Set block indication to NO00.

Possibility 1

Press **REV** key, until NO00 is indicated.

Possibility 2

Display shows any given block number.
Press **INP** + **REV**, indication jumps to NO0.

- Press key **START**. The program runs until a hold or until M30.

To continue program after hold

Press key **START**.

Program Hold

- Programmed hold M00.
- In connection with M06, if under the address T (F) a number 1 to 499 is programmed (with inch operating mode 1 to 199). If under T=0 is programmed, there is no hold.

Interventions during Program Flow

1. Program stop
2. Programm interruption

1. Program stop

INP + **REV**

Press keys **INP** + **REV**. The program jumps back to NOO (start).

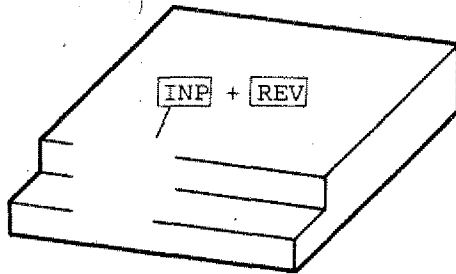

Pay attention:

If you press **START** key after **INP** + **REV**, the program starts with NOO. Your tool is not in starting position! Collision!

New start: Measures

Position the tool in program start position.

**Sonst Kollisions-
gefahr und falscher
Programmablauf**

2. Program Interruption

INP + FWD

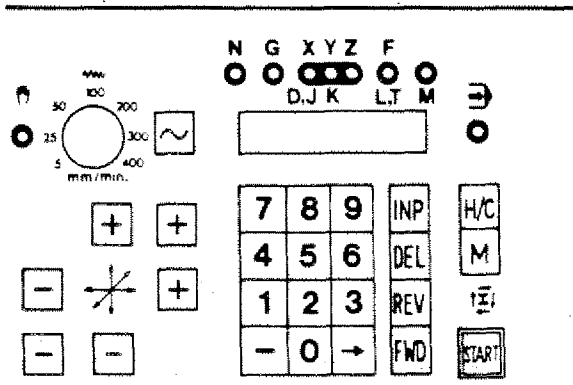

The program is stopped.

To continue program:

Press key **START**.

Why program interruption?

You may e.g.

- change the feed
- take measurements
- switch over to hand operation and carry out a correction by hand
- correct program, etc.

Effectiveness of Corrections with Program Interruption

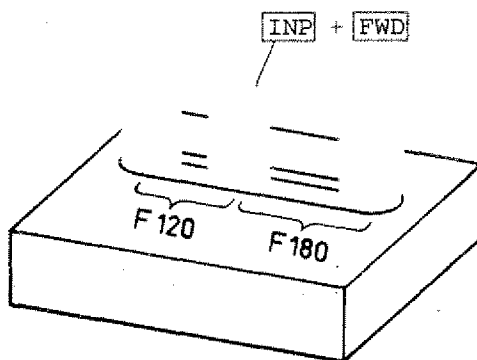

1. Corrections of feed:
Feed corrections become effective in the interrupted block.
2. Corrections of G,M,X,Y,Z-values in the interrupted block are only effective in the following program run.
3. Corrections of G,M,X,Y,Z-values in subsequent blocks will be effective when the program is continued.

9. ALARM SIGNS

- **Purpose of alarm signs** 9.1
- **Procedure in the computer when input is wrong** 9.2
- **Alarm survey, possible inputs** 9.4
- **Measure when alarm sign appears** 9.5
- **Alarm signs, details** 9.7 – 9.15

A05: M30 instruction missing

With **START** the computer checks if M30 (program end) was programmed.

A06: M03 instruction missing

(M03 main spindle ON)

This alarm only appears if threading cycles are programmed.

Attention:

The main spindle switch has to be in CNC-position!

A08	}	Compare tape operation
A09		
A10		
A11		
A12		
A14		

A13: Inch/mm or vertical/horizontal switch with full program memory

This alarm cannot be cancelled by **INP** + **REV**. You have to switch back into the original position. If you have put in a vertical mill program with switch position at horizontal mill, you have to enter the program new (with correct switch position).

A15: Wrong Y-value

For admissible data see chart.

A16: Cutter radius data missing

If a G72,G45,G46,G47,G48 instruction is called, there has to be programmed a MO6 information with cutter radius data (D) in one of the previous blocks. Without this information the computer cannot calculate the center point path.

A17: Wrong subroutine

If a subroutine is nested more than 5 times, an alarm is shown.

A18: Movement of cutter radius compensation smaller 0

Example: subtract cutter radius once
G46

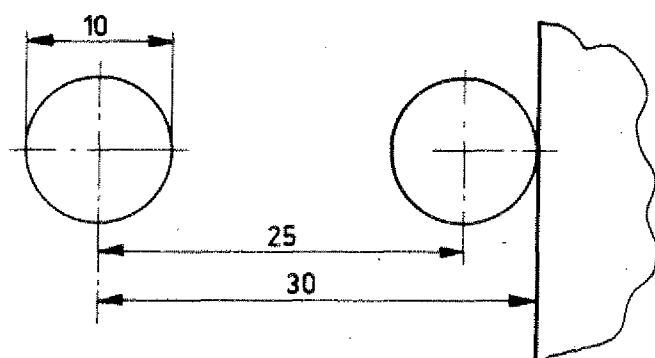

①

```
MO6/D500/S..../Z..../F...
G46
G00/X3000/Y=0/Z=0
```

Cutter moves 30 minus 5 = 25 mm

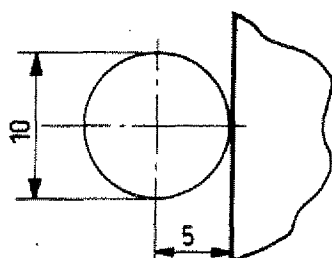

②

```
MO6/D500/S..../Z..../F...
G46
G00/X500/Y=0/Z=0
```

No movement

Cutter radius = traverse movement

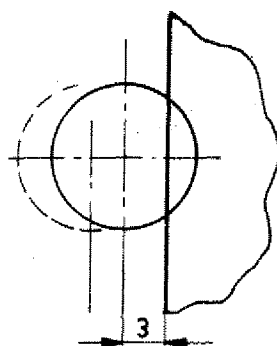

③

```
MO6/D500/S..../Z..../F...
G46
G00/X300/Y=0/Z=0
```

Alarm

Movement X=300 is smaller than cutter radius. 300 minus 500 = -200.

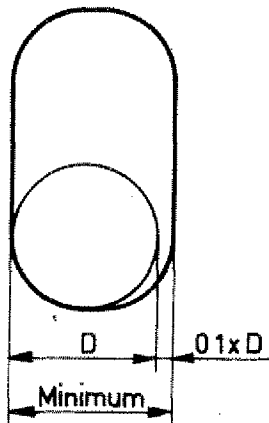

Special case – Alarm A18 with pocketing

The first measure for the pocket has to be larger or equal.

Cutter dia + 0,1 cutter dia.

Example:

Cutter dia. 10 mm

Minimum measure for pocket

$$d + 0,1 = 10 + 0,1 \times 10 = 10,1 \text{ mm}$$

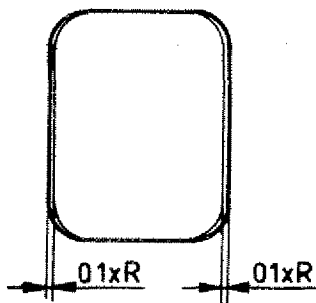

Reason:

Finishing cut 2 x 0,1 R (radius) is fixed in cycle G72.

Alarm Signs

Purpose of alarm signs:

If you put in and store data which the computer does not know, if you forget something or program a wrong block, then the computer gives an alarm sign..

The alarm sign appears on the digital read-out in form of a certain alarm number, on the monitor you get a commentary too.

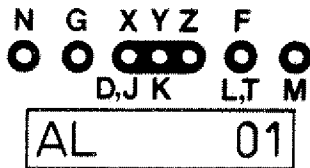

CNC-OPERATION

| N | G | X | Y | Z | F |
 A01 WRONG G/M INSTRUCTION

What happens when wrong data is put in – Alarm sign

We put in a X-value 50000, i.e. for the cross slide a traverse path of 500 mm.

1. The secretary (interface element) reports:

"They want X = 50000!"

2. The director (central processing unit, microprocessor) asks his specialists:

"Can we execute X = 50000?"

3. The specialists (operating program) answer:

"No, Mister Director! X 50000 is too high!"

4. The director instructs his speaker (output element):

"Tell them out there, we cannot do it! X 50000 is too high, put in alarm sign A02!"

What happens when wrong Data is put in?

Data Input:

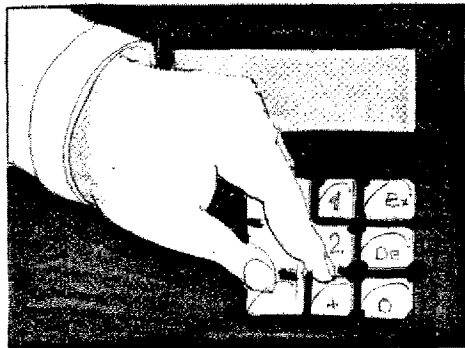

Data on digital read-out

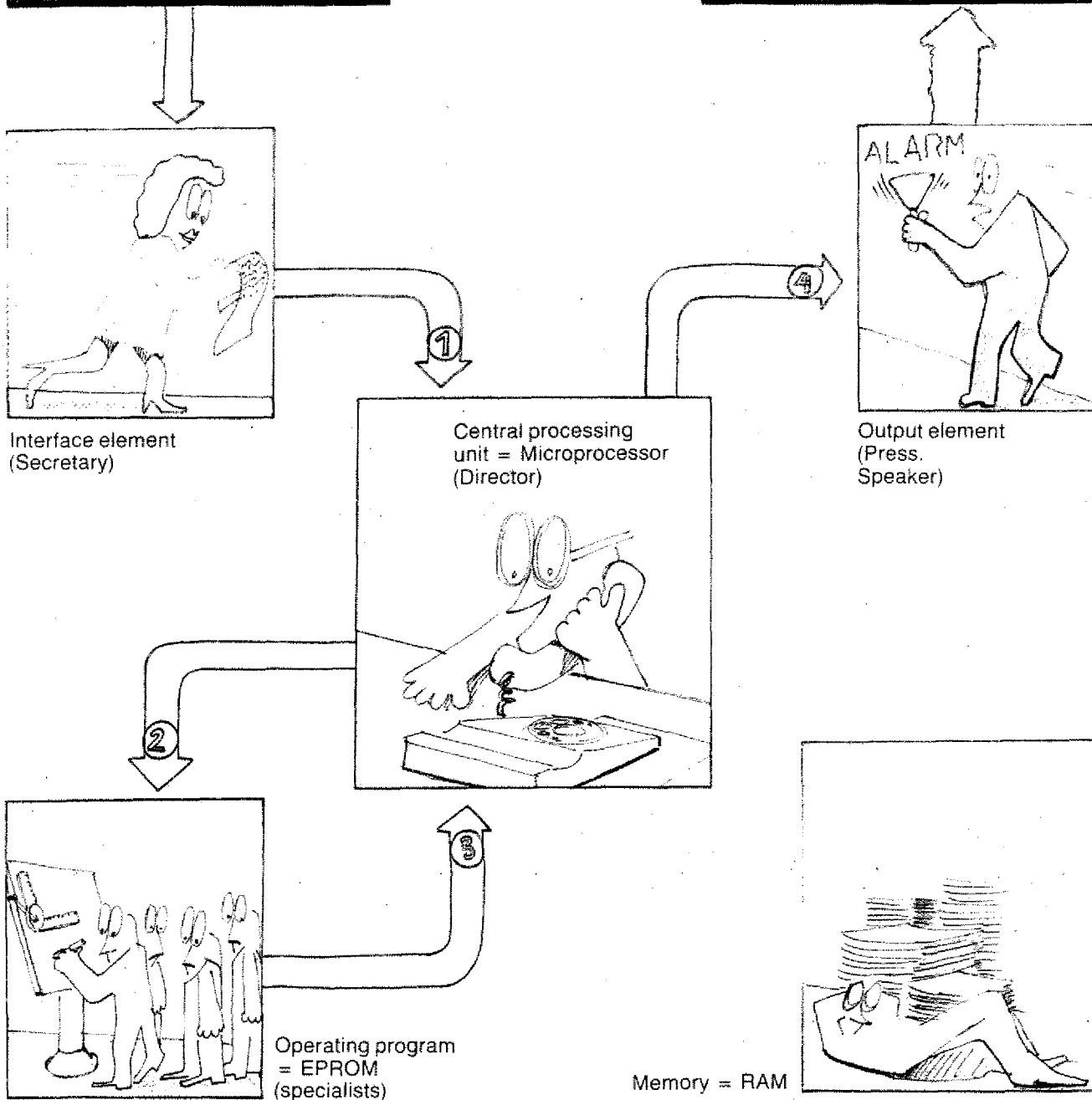
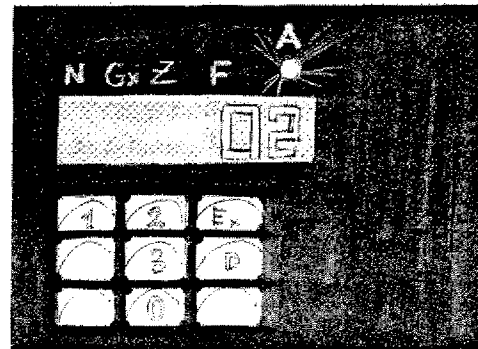

Alarm Signs

(Survey)

- AO0: Wrong G/M instruction
- AO1: Wrong radius/M99
- AO2: Wrong X-value
- AO3: Wrong F-value
- AO4: Wrong Z-value
- AO5: M30 instruction missing
- AO6: MO3 instruction missing
- AO7: No significance
- AO8: Tape end with tape operation SAVE
- AO9: Program not found
- A10: Writing protection active
- A11: Loading mistake
- A12: Checking mistake
- A13: Inch/mm switching with full program memory
- A14: Wrong mill head position/path unit with LOAD \perp /M or \rightarrow /M
- A15: Wrong Y-value
- A16: Cutter radius data missing
- A17: Wrong subroutine
- A18: Movement cutter radius compensation smaller 0

Possible Inputs

(otherwise alarms possible)

	Metric		Inch	
	Values	Fineness (mm)	Values	Fineness (inch)
X _V	0-19999	1/100 mm	0-7999	1/1000"
X _H	0-9999	1/100 mm	0-3999	1/1000"
Y _V	0-9999	1/100 mm	0-3999	1/1000"
Y _H	0-19999	1/100 mm	0-7999	1/1000"
Z _{VH}	0-19999	1/100 mm	0-7999	1/1000"
Radii	0-9999	1/100 mm	0-3999	1/1000"
D(X) milling cutter radius with MO6	0-9999	1/100 mm	0-3999	1/1000"
F	2-499	mm/min	2-199	1/10"/min
T(F) tool address MO6	0-499	1	0-199	1
L(F) jump instruction: G27		0-221		
H(F) exit signs M26		0-299		
J/K circular parameter		0-90		

Measures when Alarm appears

Alarm is on

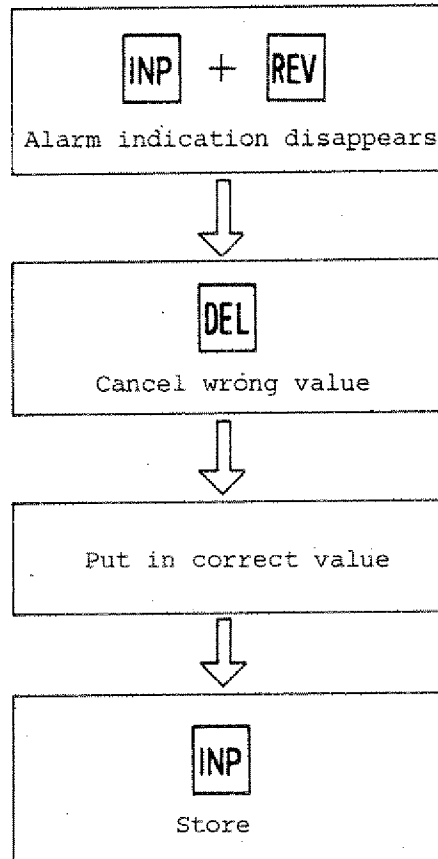

Note:

- Alarm A13 can be cancelled only by operating the option switch metric/inch, horizontal/vertical.
- Alarm sign of tape operation please compare chapter tape operation.

A00: Wrong G/M instruction

Example: G12, M55

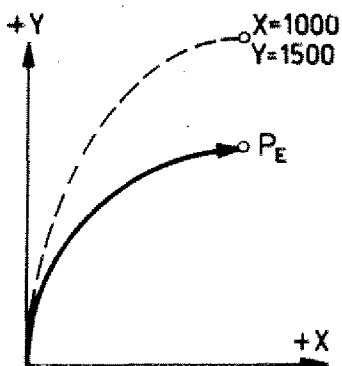

A01: Wrong radius/M99

Possibility 1: Radius larger than admissible values

Possibility 2: Wrong value for end coordinates PE of quarter arc

Example: incremental value programming

N.../G02/X1000/Y1500/

Coordinates X=1000/Y=1500 cannot be end coordinate of quarter arc.

Example: absolute value programming

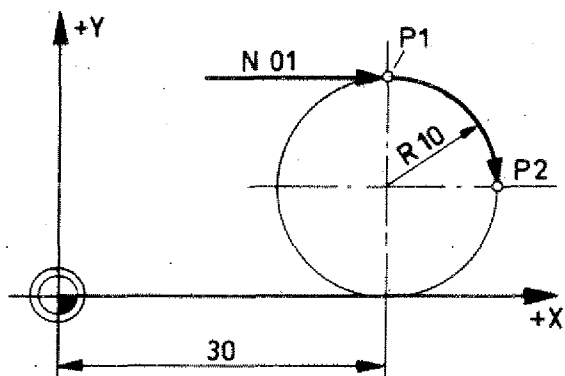

N	G	X	Y	Z	F
00	90				
1	01	3000	2000	0	100
2	02	4000	1000	30	100
3	M30				
4					Alarm

- In block N01 point P1 is programmed.
- In block N02 the quarter arc is programmed (coordinate P2). The X,Y values are correct. The Z-value would mean a circular interpolation in space (helix). This the computer does not know.

The alarm sign in this example does not appear when the program is put in but is on during the test run, automatic or single block operation.

Explanation:

At program input the computer just checks the contents of one block, it does not check the Z-value of the previous block.

A02: Wrong X-value

Compare chart for admissible values.

A03: Wrong F-value

Compare chart for admissible values.

A04: Wrong Z-value

Possibility 1: Admissible Z-value surpassed (compare chart)

Possibility 2: Threedimensional movement with absolute value programming

This alarm appears only in the test run, single block or automatic operation because the mistake cannot be recognized at program input (computer does not check contents of previous blocks at program input).

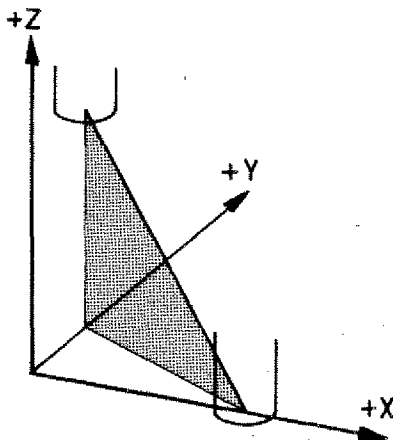

Example:

N	G	X	Y	Z	F
0	90				
:					
10	00	0	1500	3000	
11	00	3000	0	0	

Alarm

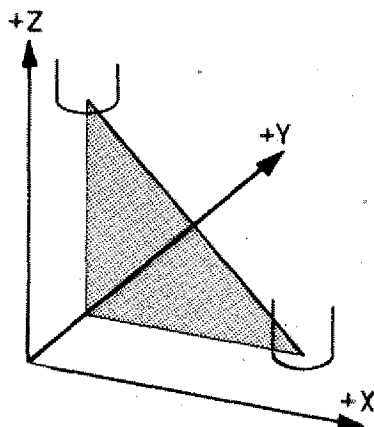

Monitor shows: Wrong Z-value; the computer accepts the X,Y values since it can carry out this interpolation and indicates the value shown last as being wrong value.

Attention:

Maybe you wanted to program Z=0 and Y1500 instead of 0. The computer cannot know this. The computer indicates Z as wrong value since it does not know your thoughts.

Chapter 10

Cassette Operation

RS-232 C Operation

Magnetic Tape Operation

The tape enables you to store programs and to feed them into the computer memory.

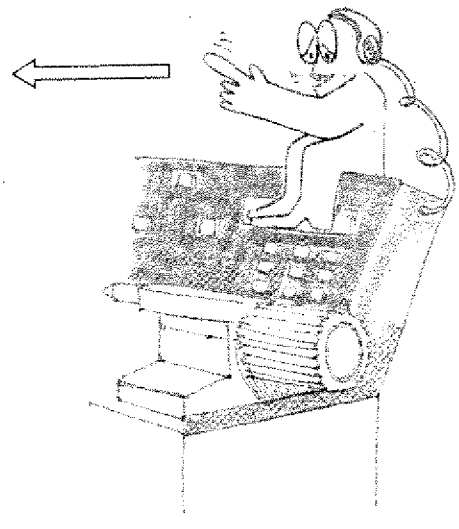
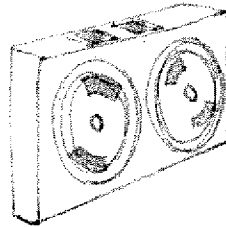

1. Storing on tape

To transmit from computer memory to tape: We call this mode of operation SAVE or CHECK.

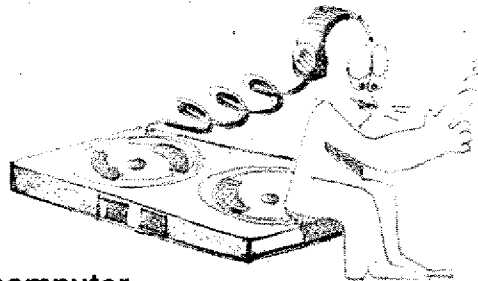

2. From tape into computer

To transmit the program from tape into the computer memory: we call this mode of operation LOAD.

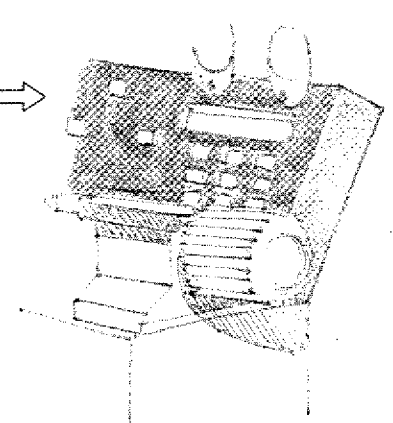

Some data

- Memory capacity per tape side: approx. 400 blocks.
- Operation time per tape side: approx. 90 sec.

Operation advice

1. Use only digital cassettes
2. Erase new cassettes completely (see page 7.23). The test impulse from the final control of the producer can cause Alarm A11 or A12.
3. Main drive motor must not run during LOAD, CHECK, SAVE and ERASE operation.
4. Do not put down tape near main motor.

Magnetic Tape Operation

Transmission of a program from machine memory to magnetic tape

Mode of operation

SAVE = transmit from machine memory to magnetic tape

CHECK = control of transmitted (loaded) program

1. Press key **→** until word indication G lights up. Press key **DEL**.
The indicated value disappears from the digital read-out.

2. Put in G65.

Press keys **6 5 INP**. On the read-out you see C indicated. **C**
magnetic cassette tape operation.

3. Press key **FWD**.

On the read-out appears **C P**

4. Put in program number.

You can put in figures 000 - 099
00 - 09
0 - 999

The sequence of the figures can be chosen as you like. Example for input of a program with number 76: Press keys **7 6**.

5. Press key **INP**.

The transmission / loading starts.

5.1. First free space on the tape is sought.

If there are not data on the tape, it will advance approx. 4 seconds and rewind approx. 2 seconds.

Band without data on:

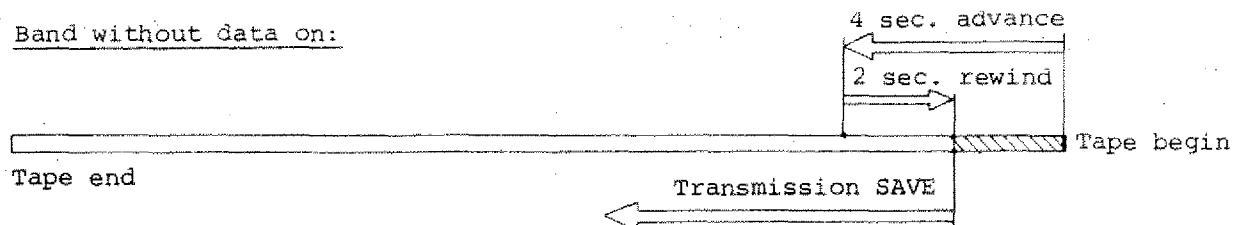

If there are already data/programs loaded on the tape, then the tape will advance to the end of the program which was loaded last. Then advance 4 seconds and rewind 2 seconds.

Tape with programs already loaded:

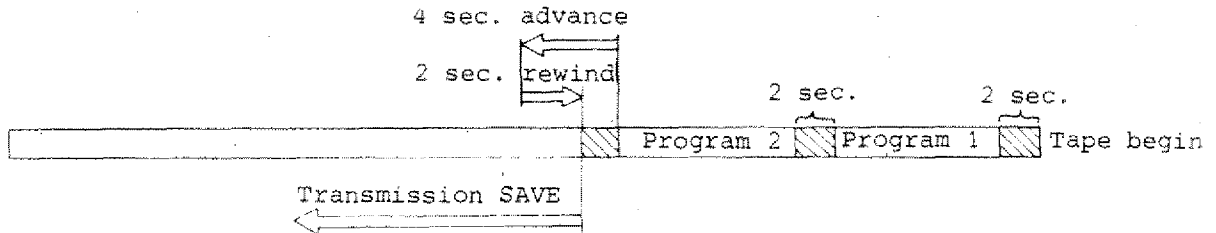

5.2. Transmission operation SAVE

The digital read-out indicates

C	S	A	
---	---	---	--

 SA is the abbreviation for SAVE.
 The program/data are "saved" from the machine memory - where they could be deleted - onto the tape.

5.3. At the end of the transmission operation the tape rewinds to the tape start.

5.4. Control operation CHECK

The digital read-out indicates

C	C	H	
---	---	---	--

 The data in the machine memory are compared with the data loaded on the tape.
 If you have already programs loaded on the tape, then the digital read-out will indicate these on the read-out whilst the tape advances. It will advance to the program loaded last and then the "CHECK" will be carried out.

CHECK of loaded program

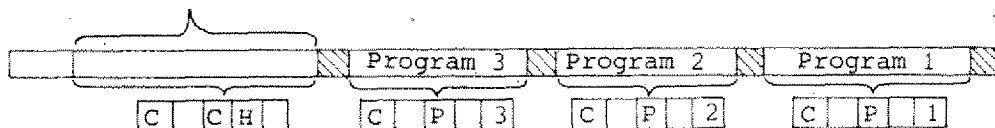

6. After CHECK the tape rewinds. The program is loaded on the tape.

Please never take out tape during operation!

Mode of operation LOAD

Transmission of program from tape to machine memory

Mode of operation LOAD

1. Press key \rightarrow until word indication G lights up. If a figure of the G-function appears, press key DEL. Then indication on read-out disappears.

2. Put in G65.

Press keys $\boxed{6}\boxed{5}\boxed{INP}$. Read-out indicates $\boxed{C}\boxed{}\boxed{}\boxed{}$

3. Press key INP.

Read-out indicates $\boxed{C}\boxed{P}\boxed{}\boxed{}$.

4. Put in number of program.

E.g. for program number 76 you press keys $\boxed{7}\boxed{6}$. On read-out: $\boxed{C}\boxed{P}\boxed{7}\boxed{6}$

5. Press key \boxed{INP} .

5.1. The program number $\boxed{7}\boxed{6}$ is looked for.

If you have other programs on the tape already, then these numbers appear on the digital read-out.

E.g. $\boxed{C}\boxed{P}\boxed{7}\boxed{4}$ or $\boxed{C}\boxed{P}\boxed{7}\boxed{5}$

5.2. Loading:

When the wanted program 76 is found, the loading operation starts.

On the digital read-out you see $\boxed{C}\boxed{L}\boxed{O}\boxed{}$

LO is the abbreviation for "load".

5.3. After the loading is done, the tape rewinds. The read-out shows NOO.
Program number 76 is stored in the machine computer.

6. If you press key \boxed{START} then the program starts operating.



From tape to machine

From machine to tape

LOAD	SAVE, CHECK
1. Put in G 65 G • [][][][6 5]	1. Put in G65 G • [][][][6 5]
2. Press INP C [][][][]	2. Press INP C [][][][]
3. Press INP C [P][][]	3. Press FWD C [P][][]
4. Put in program number C [P . .]	4. Put in program number C [P . .]
5. Press INP Program is sought and will be loaded in machine. C [L O]	5. Press INP - Free space on tape is sought. - Machine program is transmitted/loaded on tape (SAVE) C [S A] - Loaded program on tape is checked/compared with machine program. C [C H]
6. If program is loaded in machine, then read-out indicates: N • [] [] [0 0] Program can be started.	6. If operation is through, then indication on read-out: N • [][][0 0]

Alarm Signs – Tape Operation (Summary)

- A08 - Tape end reached during loading of program from machine memory to tape (only with mode of operation SAVE)
- A09 - Selected program cannot be found (mode of operation LOAD). Tape is full. MO6 is not put in in selected program (mode of operation LOAD).
- A10 - Writing protection active
- A11 - Loading mistake
- A12 - Checking mistake

General

When switching off machine (also when current breaks down) an interference pulse is put onto the tape. This interference pulse does not have any effect since the loading start only after 2 seconds of tape advance.

Thus:

Tape has to be rewind (automatically). Never take tape out during rewind operation.

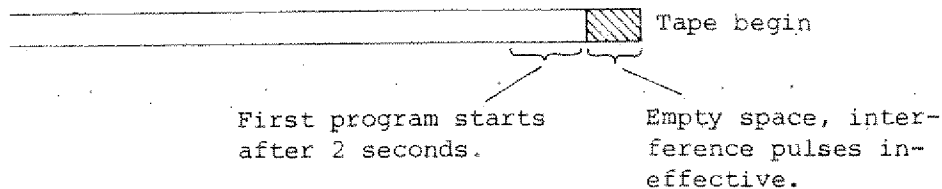

Alarm sign A08:**Only when using mode of operation "SAVE"!****Reason**

Tape finish during loading (SAVE) from machine memory to tape.
(A08 only when using mode SAVE)
Alarm sign A08 appears on digital read-out.

Measures

- Press INP and REV.
Tape rewinds to tape begin.
- Digital read-out indicates NOO.
- Put in new tape and repeat loading operation.

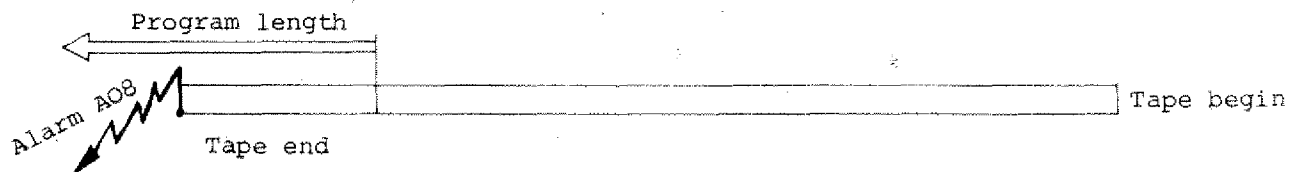
**Attention:**

If you put in this tape and want to load the next finished program (transmit from tape to machine memory) A09 appears " No program end found!

Alarm sign A09:

Only when using mode of operation "LOAD"!

A09 - Reason 1

Selected program not found.
If you call a non-existing program number when "loading" (from tape to machine memory), then alarm A09 appears.

Measures

- Press **INP** + **REV**
The tape rewinds. The digital read-out indicates after that NOO.
- Look for program on another tape (in case you are sure you put it in).

Example: You look on this tape for program no. 5



A09 - Reason 2

Selected program not fully on tape (M06), since tape was finished when loading from machine memory to tape (already in mode of operation SAVE you had alarm A08).

Measures

- Press **INP** + **REV**
Tape rewinds, read-out indicates NOO.
- Look for program on other tape (in case you are sure that you put it in)

Example: You call on program no.19

Program 19 does not have M06, thus alarm A08 was indicated already during mode of operation SAVE.



A10 – Writing protection active:

Only when using mode of operation “SAVE” and “ERASE”!

If you remove the writing protection (i.e. the black caps) you cannot put any more data on this tape side.

If you put in such a tape side and you want to transmit a program from the machine memory to the tape, alarm sign A10 appears.

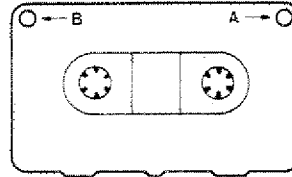

Measures:

Press **INP** + **REV**

Tape rewinds, put in other tape or mount writing protection again.

A11 – Load mistake:

Only when using mode of operation “LOAD”!

A11 – Reason 1

Motor is switched on or is being switched on during loading (tape-machine).

The program on the tape was not destroyed by switching on the motor.

Measures

- Switch off motor
- Press **INP** + **REV**
The tape rewinds, the read-out indicates NOO.
- Repeat loading operation.
- If you have A11 indicated also with the following loading operation, please see reason 2.

A11 – Reason 2

The program on the tape is destroyed. The reasons for it could be a mechanical fault on the tape, a power failure - or the machine was switched off when tape was not rewound.

Measures

Transmit program to new tape.

Summary measures

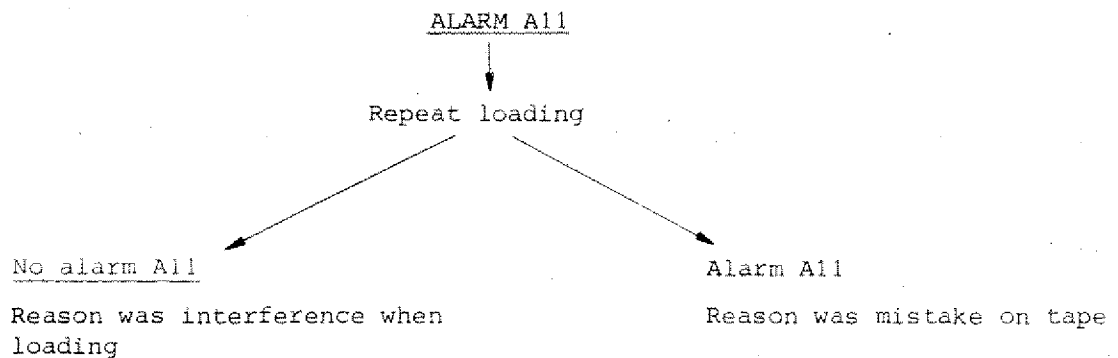

A12 – Check mistake:

Only when using mode of operation "CHECK/SAVE"!

Possible reasons:

- Tape faulty
- Interference pulse: main motor switched on, short power failure, interference pulse from electrical conductor (lightning, switching on of soldering transformer ...)

The interference pulses can happen both when using mode of operations SAVE or CHECK.

Alarm sign A12 in mode of operation "SAVE" – Remedy

Store program under another number.

Explanation:

You cannot delete the false program just by its own. Thus you have to give to this program a new number, if you store in on the same tape. If you would use the same program number, then alarm A11 would appear when loading (tape - machine) since only the first one of two identical program numbers can be called on.

Measure:

- Put in **INP** + **REV**, tape rewinds, read-out shows NOO.
- Put in same program under a new number.
- If alarm A12 appears again, then tape is defective.

Interference during SAVE

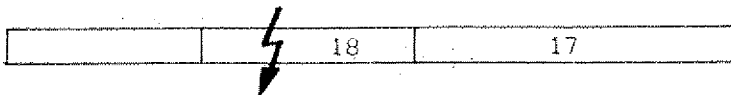

Same program has to be put in under new program number.



Alarm sign A12 in mode of operation "CHECK"

During CHECK operation there may occur an interference impulse and alarm sign A12 will be indicated, without a defective tape being the reason.

Check:

- Press **INP** + **REV**.
Tape rewinds to begin, on read-out NOO.
- Load tape into machine memory. If there is no alarm A11 when loading, then the program is o.k.
- During loading A11 is indicated: the following is necessary - New tape, delete complete tape or put in program anew under another number.

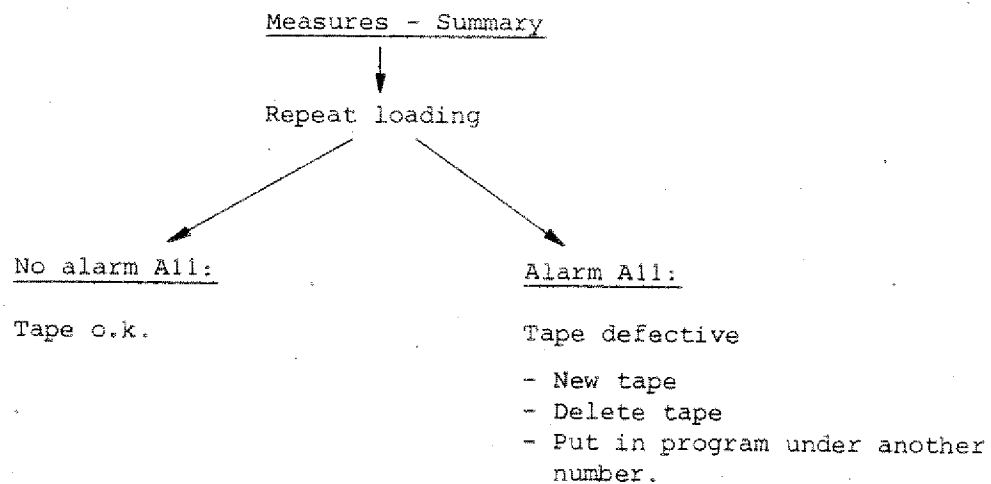

Mode of operation "ERASE" (Erasing the tape)

1. Press key \rightarrow until word indication G lights up. If you see a figure of a G-function indicated on the digital read-out, then press $\boxed{\text{DEL}}$.
2. Put in G65
Press $\overline{6} \overline{5} \text{ INP}$, on the display you see
see $\boxed{\text{C}} \boxed{} \boxed{} \boxed{}$
3. Press \rightarrow + $\boxed{\text{DEL}}$ at the same time,
on the display you see $\boxed{\text{C}} \boxed{\text{E}} \boxed{\text{R}} \boxed{\text{A}} \boxed{\text{S}} \boxed{\text{E}}$
The tape is erased.
After that the read-out shows NOO

Program Interruption during Tape Operation

Only when using mode of operation LOAD,
CHECK, ERASE.

Program interruption

Press $\boxed{\text{INP}}$ + $\boxed{\text{REV}}$
Tape rewinds to tape begin.

Why program interruption?

When using mode of operation LOAD:

If you find out that you called a non-existing program. If you press $\boxed{\text{INP}}$ + $\boxed{\text{REV}}$ the tape will not advance to the tape end but rewind immediately.

When using mode of operation CHECK:

If you do not want to wait for CHECK operation.

When using mode of operation ERASE:

It is enough that you erase about 10 seconds. When loading anew the tape machine will erase automatically all other remaining data.

When putting in the Tape, pay Attention:

1. Putting in with left spool full

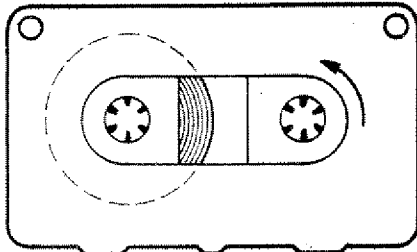

- If you switch off the machine, the tape advances 1 second.

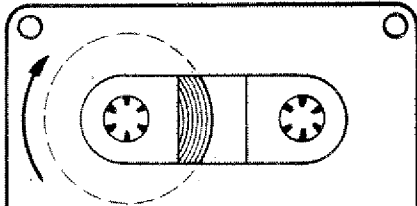
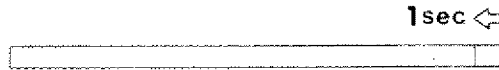

- If you switch on the machine, the motor rewinds the tape 2 seconds. So it is made certain that the tape is at the very beginning.

2. Putting in with right spool full

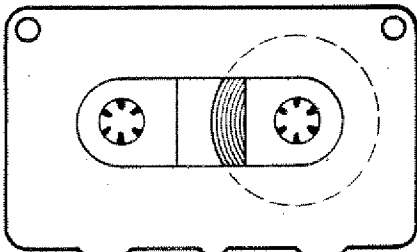

- If you put in the tape and program G65, then the tape rewinds to the beginning.

- If you put in the tape and not program G65, and switch on and off the machine, the following happens:

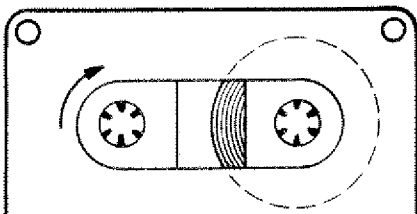

Switch on:



The tape rewinds 2 seconds.

Switch off:

The tape advances 1 second.

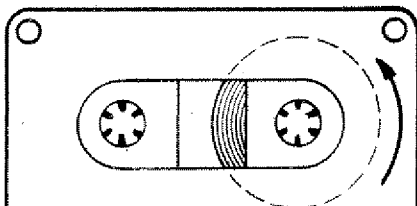

If you carry on like this, the tape moves further through the switching on and off and you get an interference pulse on the tape. A stored program will be registered.

RS-232 C Operation — G66

V24 Operation

20 mA Operation

RS-232 C is an international standardized Interface.

It is an Interface for information interchange. Via this Interface data can be transmitted to peripheric apparatus and vice-versa.

The data are transmitted via a cable. For the specific apparatus a cable has to be connected by an expert.

The description how to connect cables are found in the wiring diagrams of the producers.

Some Examples

Connecting a paper tape puncher and paper tape reader

The program of the F1-CNC can be punched on a paper tape:

Vice-versa:

From a paper tape the program can be transmitted to the F1-CNC.

Printing a program

Via the RS-232 C Interface the program in the F1-CNC can be printed on a list.

Connection of computers

Via RS-232 C computers and computer systems can be linked to the F1-CNC. Programs can be transmitted to the F1-CNC and vice-versa.

For computer connection a specific Software is necessary.

The Software is an encoding information which "translates" the code of the computer to the code of the machine. This Software has to be written by an expert for the specific computer type.

Activating RS 232:

RS 232 is activated via G66. G66 does not enter the memory, it is a switching function.

Examples:

● Transmission from paper tape to memory of F1-CNC

(With "request to send" signal)

- Switch to CNC-mode (memory must be empty)
- Insert paper tape
- Start paper tape reader



1. Program G66

2. Press **INP**

On the display appears A

(A is the abbreviation for ASCII = American Standard Code for Information Interchange)

3. Press **INP**

The display shows A L O

(LO = LOAD)

The program is transferred. At the end of the transfer the display shows N 00

● **Transmission from paper tape to F1-CNC
(without "Request to send" signal)**

- Insert paper tape
- Switch to CNC-mode

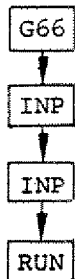

1. Program G66
2. Press **INP** The display shows

A

3. Press **INP** The display shows

A	L	O
---	---	---
4. Start paper tape reader (transmission begins)

● **Transmission from F1-CNC to paper tape
(with or without "Request to send" signal)**

- Switch to CNC-mode
- Insert paper tape
- Start paper tape puncher



1. Program G66
2. Press **INP** Display shows

A



3. Press **FWD** Display shows

A	S	A
---	---	---

(SA = SAVE)
The paper tape is punched.

PROGRAM SHEET EMCO F1 CNC

N	G (M)	X (J) (D)	Y (K) (S)	Z	F (L) (T) (H)	Remarks

Part Nr.	Part Name	Sheet Nr.	 <input type="checkbox"/>	mm <input type="checkbox"/>
Program Nr.	Name	Date	 <input type="checkbox"/>	inch <input type="checkbox"/>

PROGRAM SHEET EMCO F1 CNC

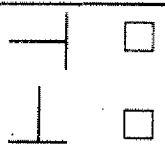

N	G (M)	X (J) (D)	Y (K) (S)	Z	F (L) (T) (H)	Remarks
Part Nr.		Part Name		Sheet Nr.		 <input type="checkbox"/> mm <input type="checkbox"/> <input type="checkbox"/> inch <input type="checkbox"/>
Program Nr.		Name		Date		

PROGRAM SHEET EMCO F1 CNC

N	G (M)	X (J) (D)	Y (K) (S)	Z	F (L)(T) (H)	Remarks

Part Nr.	Part Name	Sheet Nr.	<input type="checkbox"/> <input type="checkbox"/>	mm <input type="checkbox"/> inch <input type="checkbox"/>
Program Nr.	Name	Date	<input type="checkbox"/> <input type="checkbox"/>	mm <input type="checkbox"/> inch <input type="checkbox"/>

PROGRAM SHEET EMCO F1 CNC

N	G (M)	X (J) (D)	Y (K) (S)	Z	F (L) (T) (H)	Remarks
Part Nr.	Part Name	Sheet Nr.	 <input type="checkbox"/> mm <input type="checkbox"/>  <input type="checkbox"/> inch <input type="checkbox"/>			
Program Nr.	Name	Date				

F1-CNC, Isometric

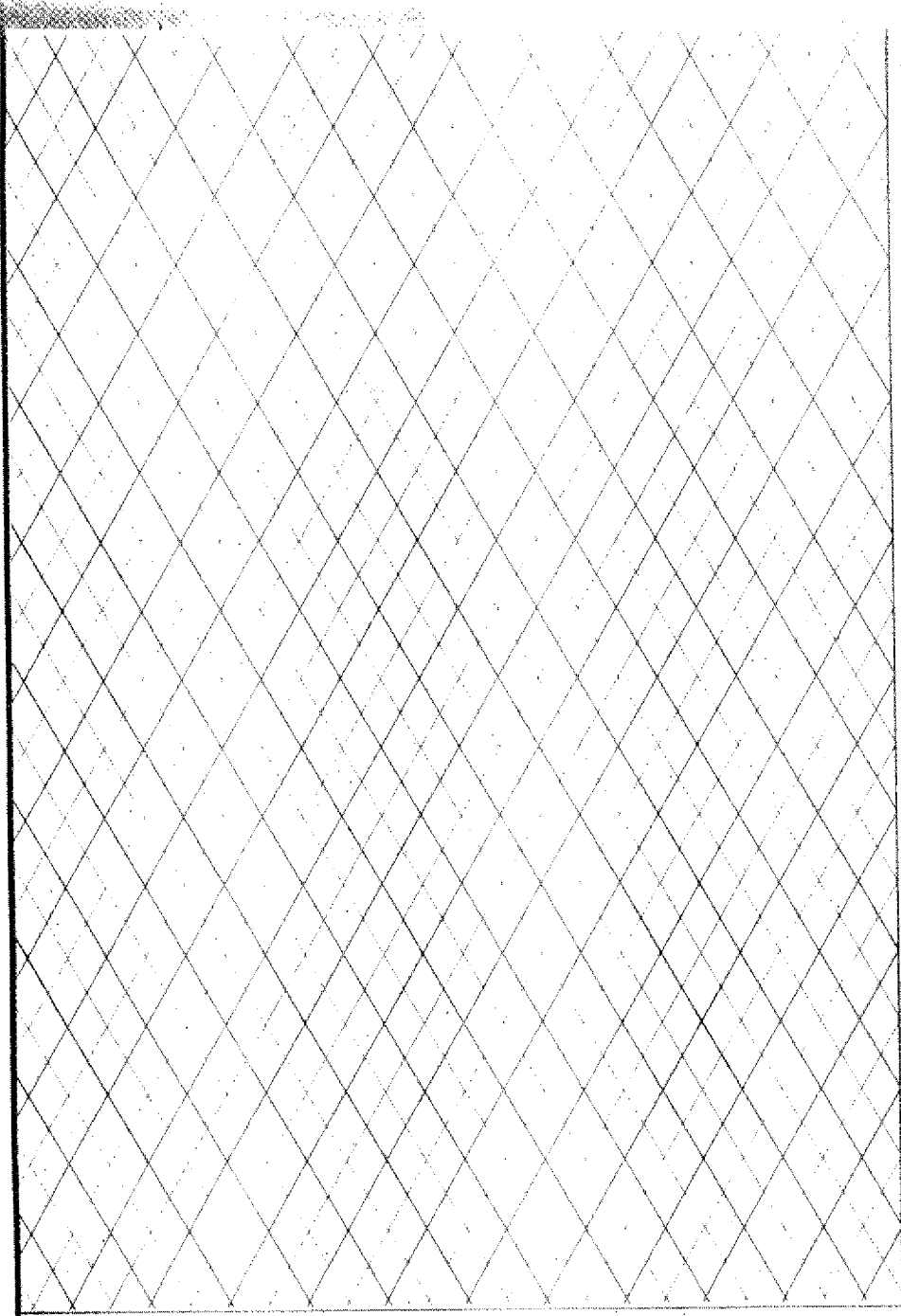

mm

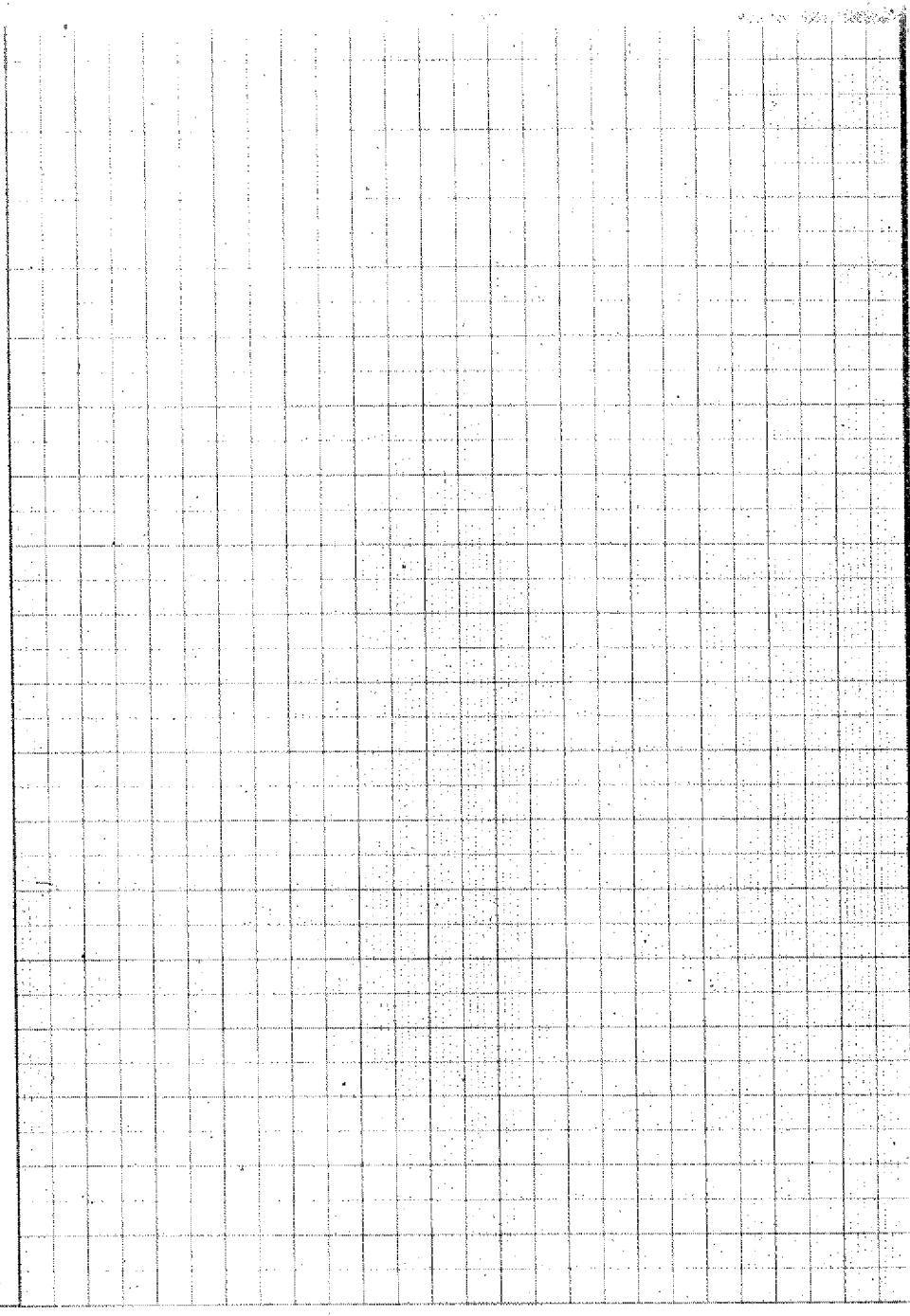

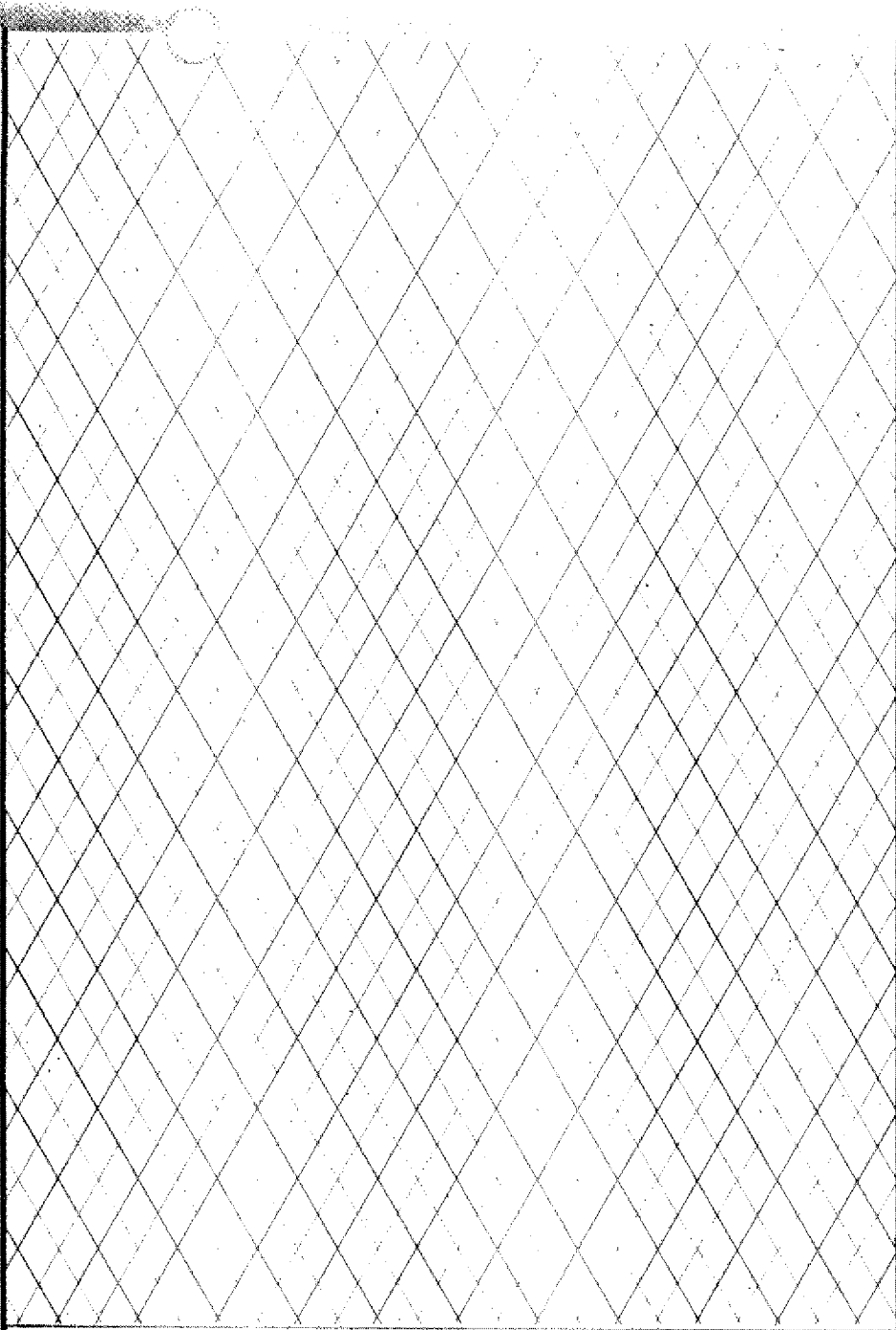

mm

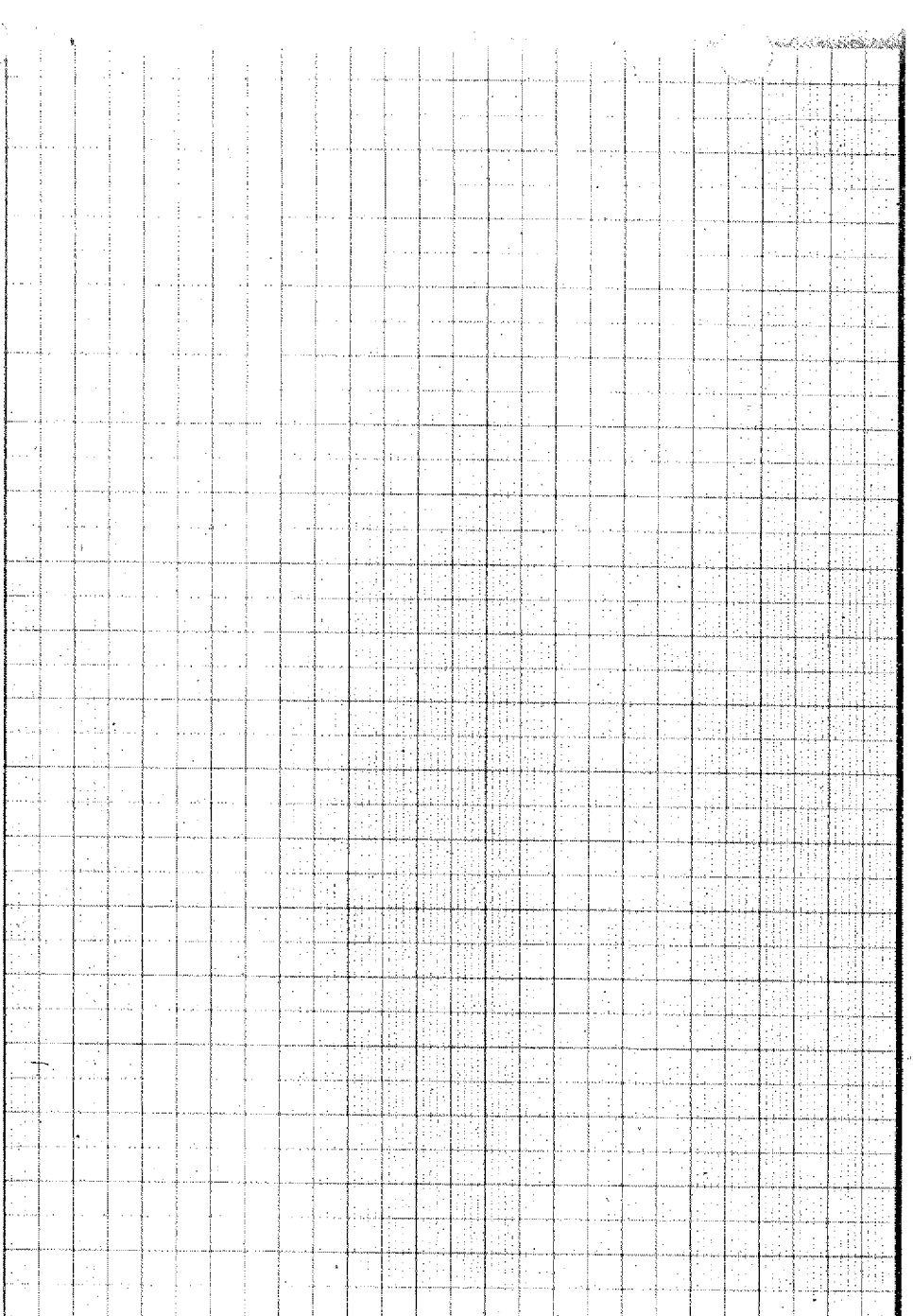

F1-CNC, Isometric

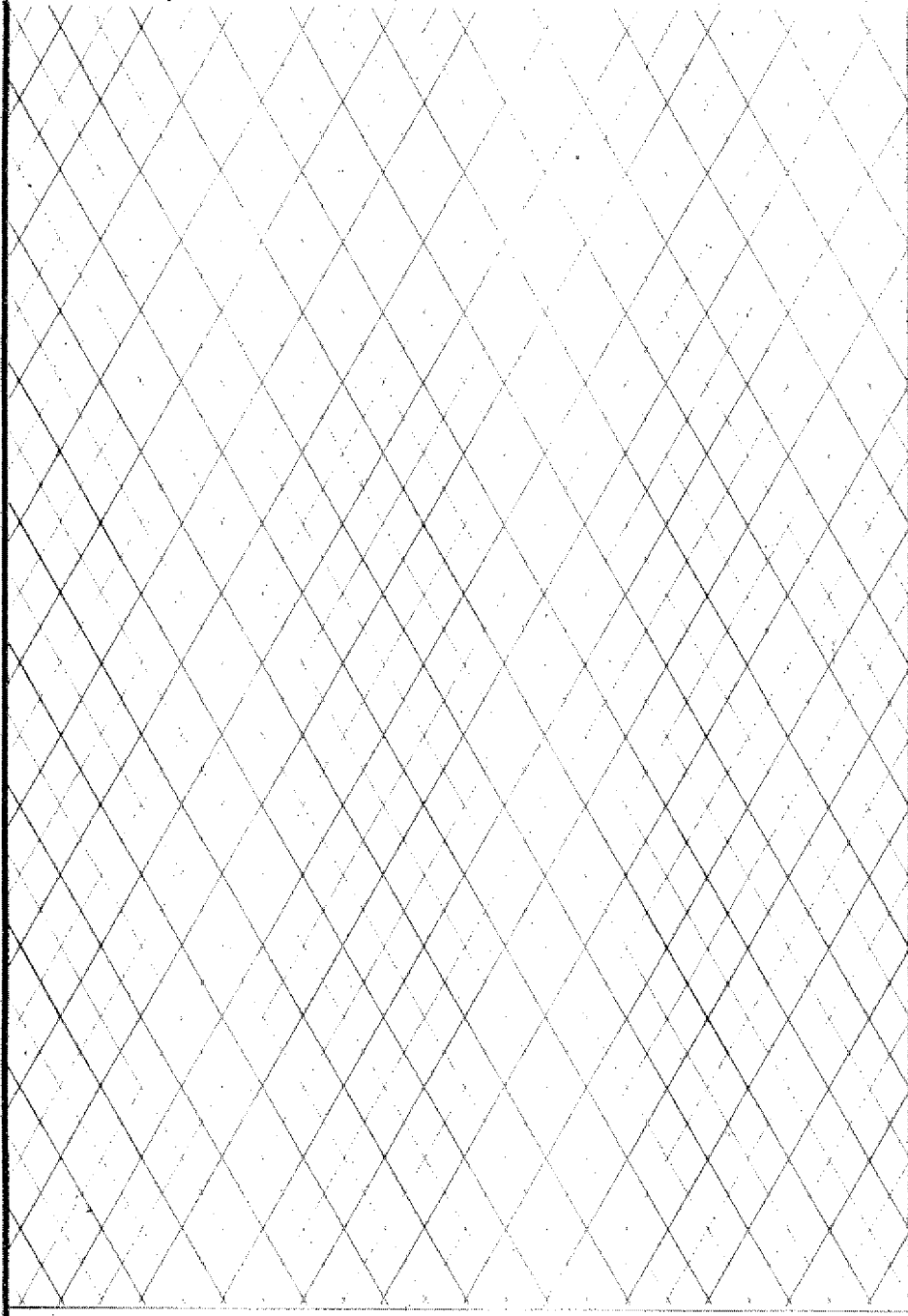

mm

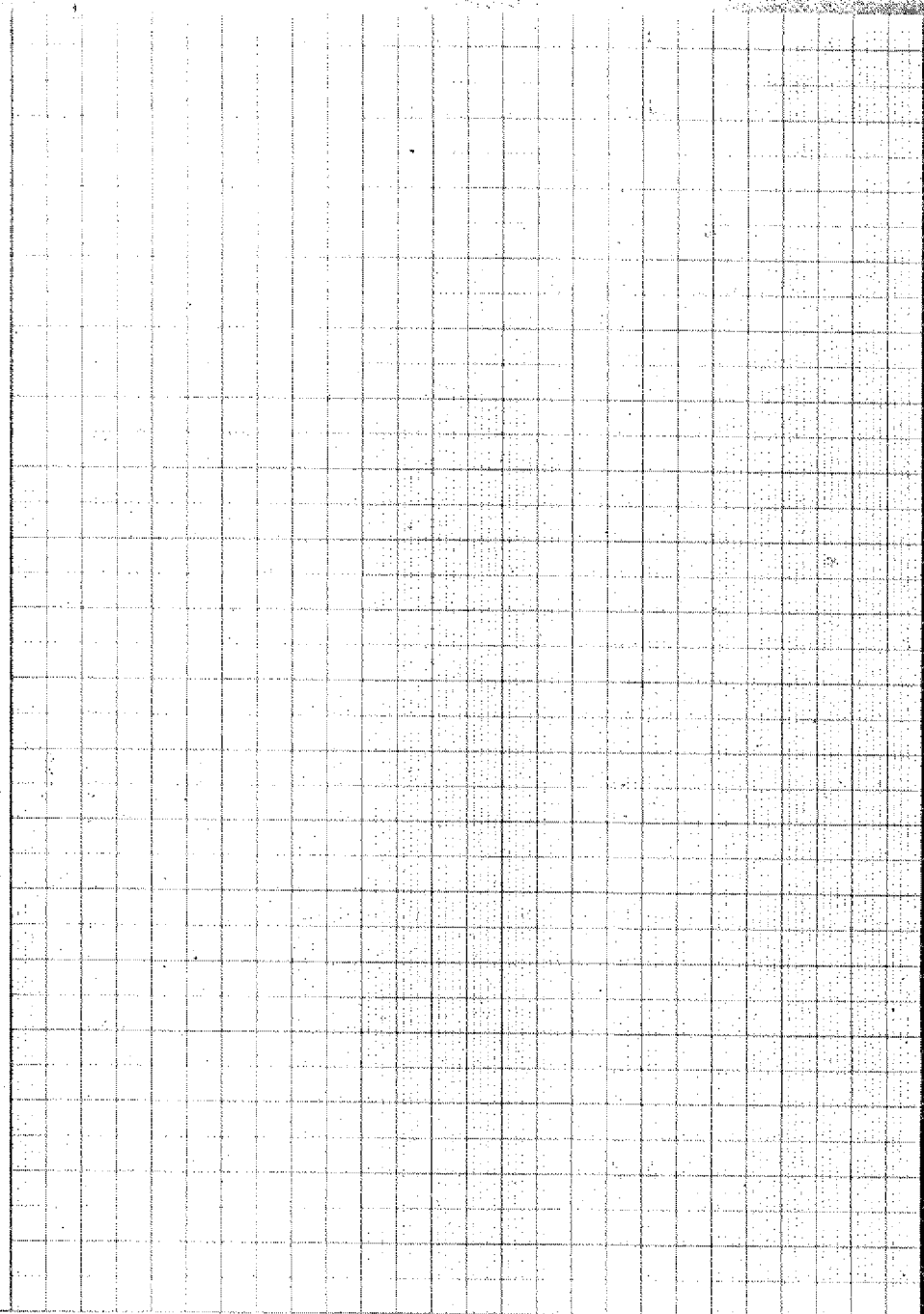

1 1-0110, 12/11/11

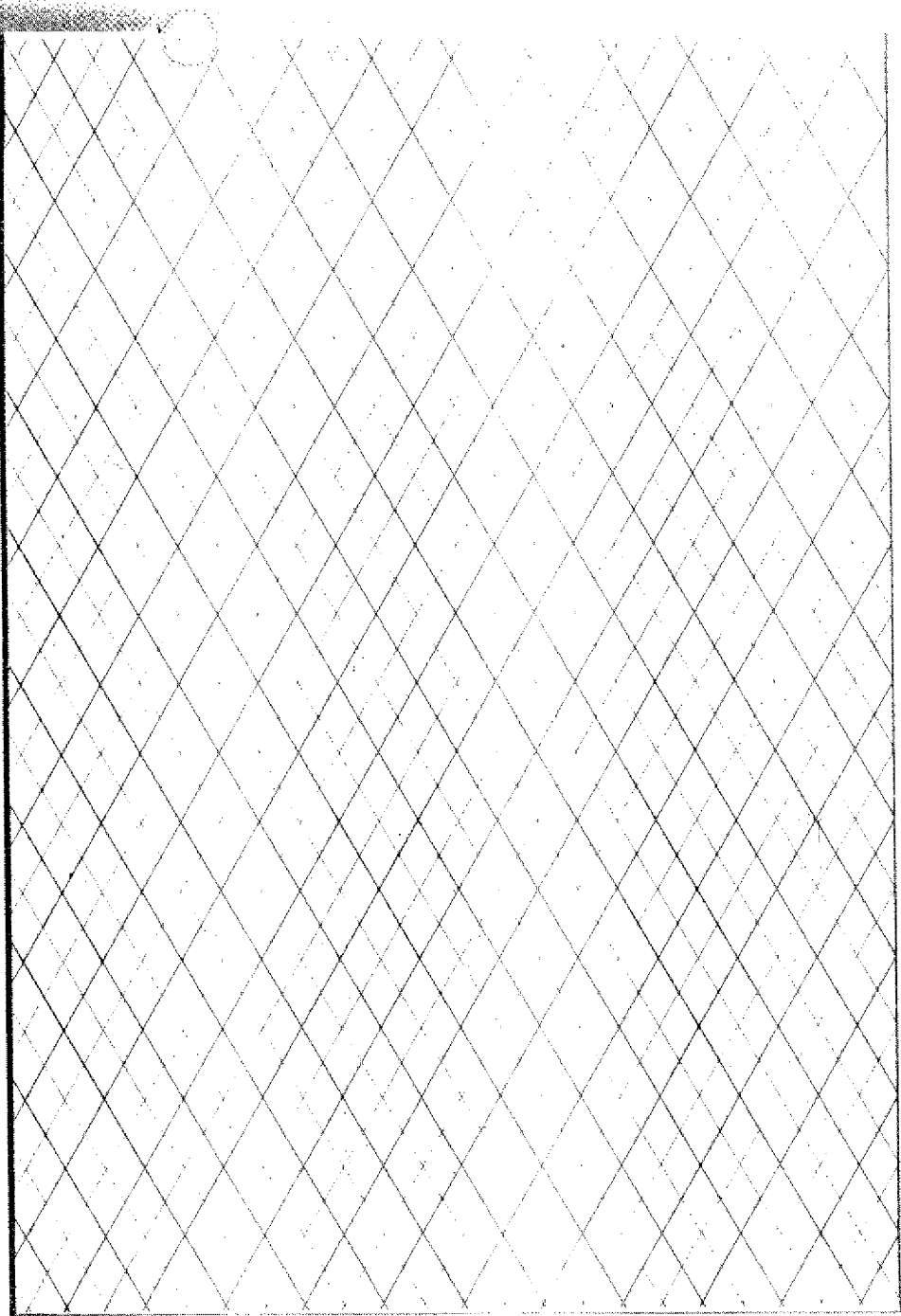

mm

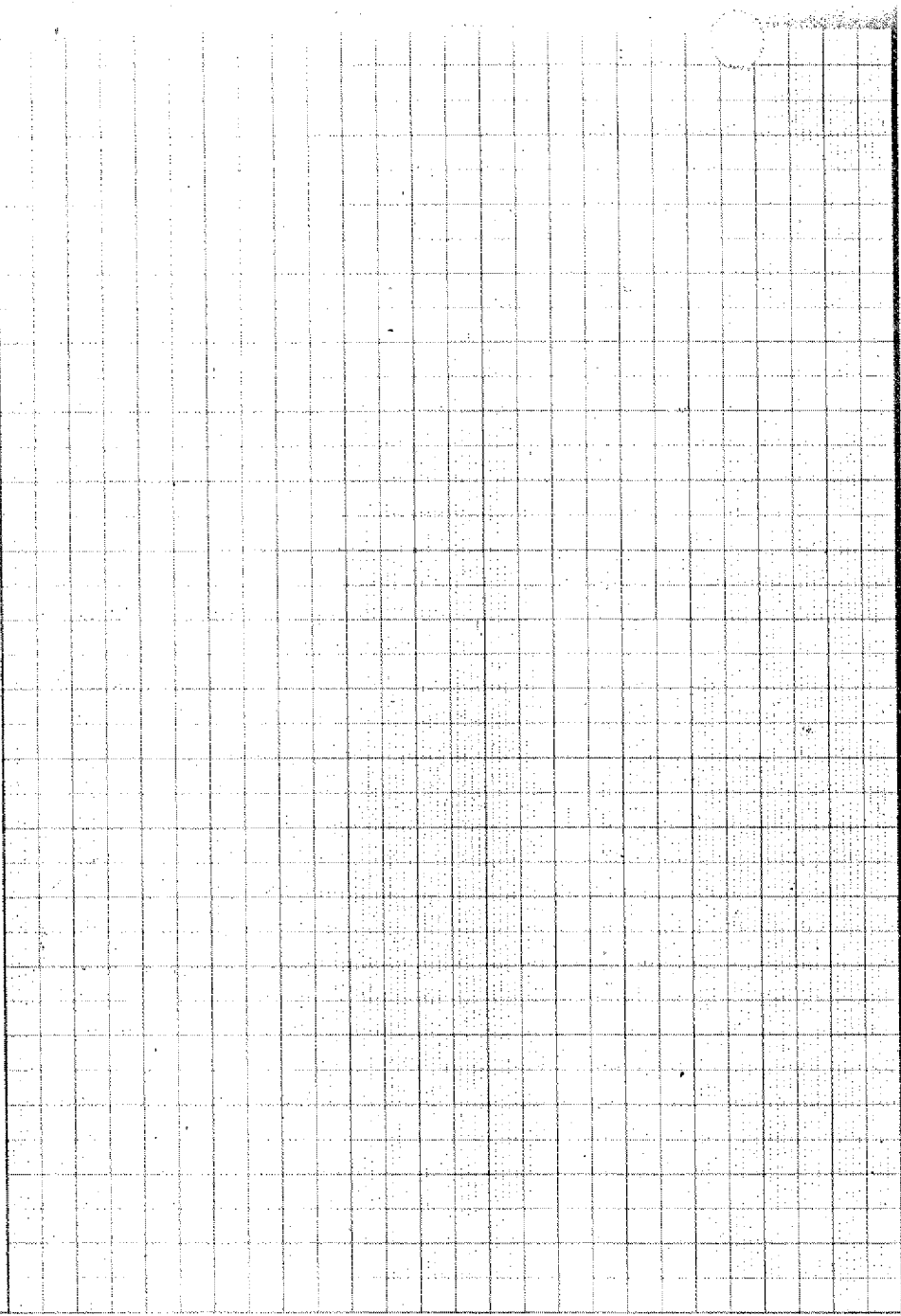

F1-CNC, Isometric

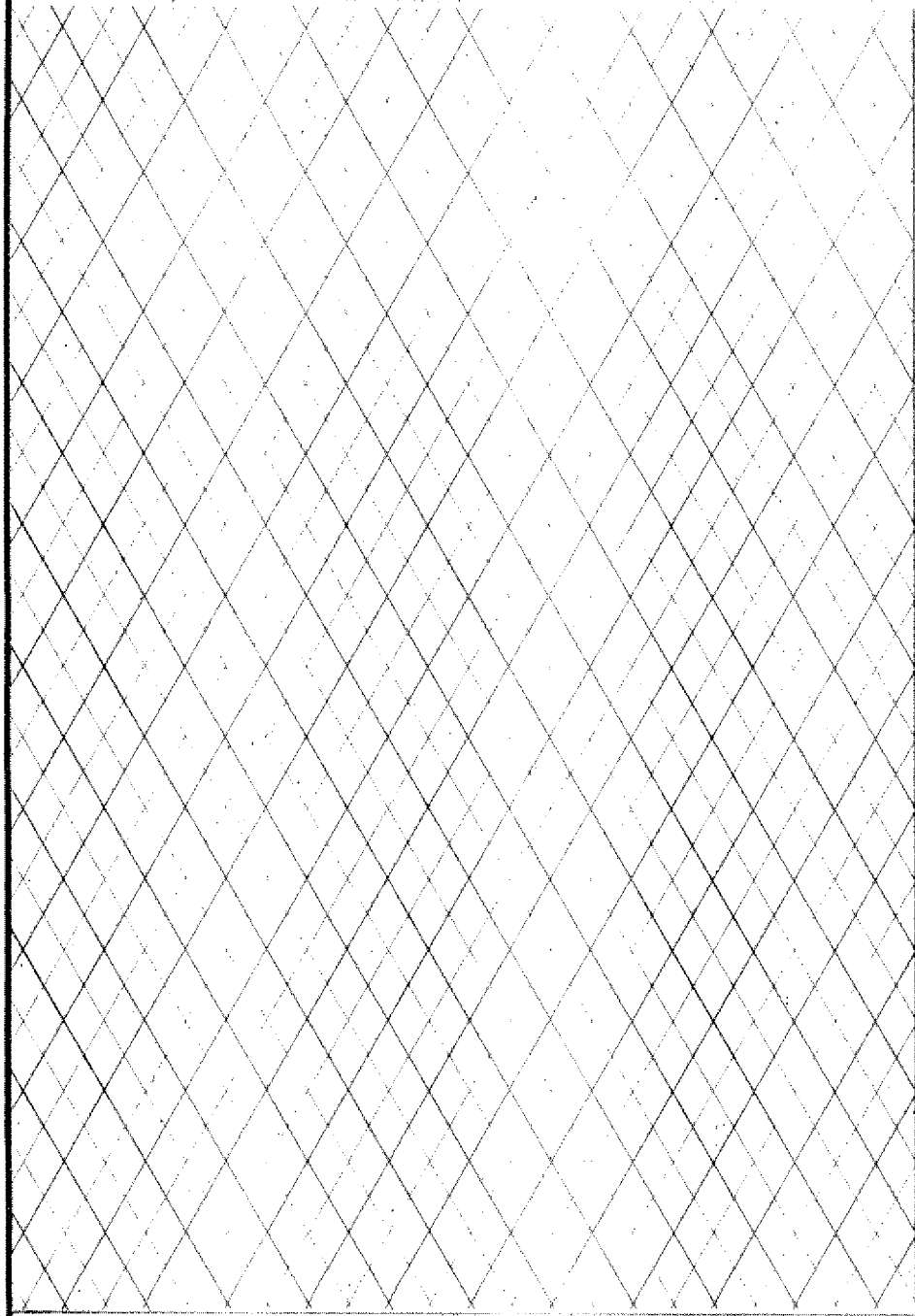

mm

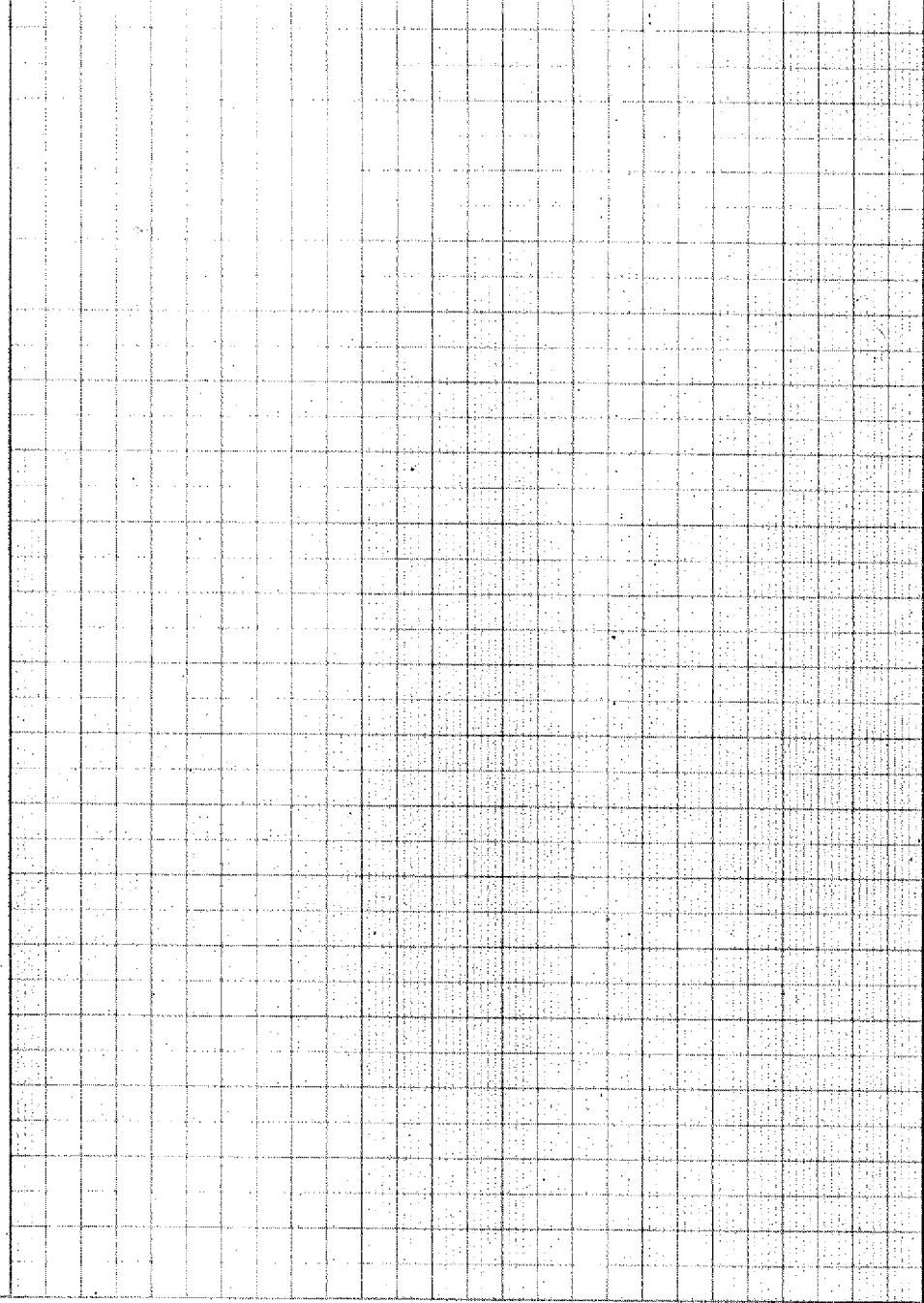

Tool Data Sheet

T1	T2	T3	T4	T5	T6	T7	T8

d							
D = $\frac{d}{2}$							
F							
t							
S							
HZ							
HZK							

d (mm) Cutter dia.
 D (mm) Cutter radius
 F (mm/min) Feed speed
 t (mm) Max. milling depth
 S (U/min) Spindle speed
 HZ (mm) Difference measure
 HZ_K (mm) Corrected difference measure

Vertical axis system

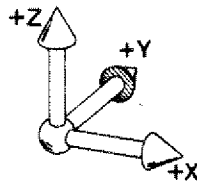

Horizontal axis system

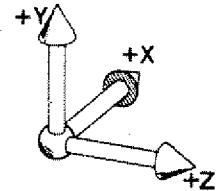

Zero-point of workpiece
 Start position
 Tool change position

Zero-point offset (G92)

X _____ mm

Y _____ mm

Z _____ mm

Drawing no.:
 Denomination:
 Workpiece material:
 Program no.
 Name:
 Date:

Tool Data Sheet

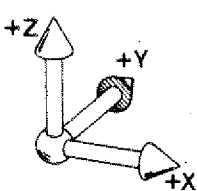
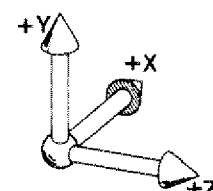
	T1	T2	T3	T4	T5	T6	T7	T8
d								
D = $\frac{d}{2}$								
F								
t								
S								
HZ								
HZK								
<p>d (mm) Cutter dia. D (mm) Cutter radius F (mm/min) Feed speed t (mm) Max. milling depth S (U/min) Spindle speed Hz (mm) Difference measure Hz_K (mm) Corrected difference measure</p>					<div style="display: flex; justify-content: space-around;"> <div style="text-align: center;"> <p>Vertical axis system</p>  </div> <div style="text-align: center;"> <p>Horizontal axis system</p>  </div> </div>			
Zero-point of workpiece Start position Tool change position					Zero-point offset (G92) X mm Y mm Z mm			
					Drawing no.: Denomination: Workpiece material: Program no. Name: Date:			

Tool Data Sheet

T1	T2	T3	T4	T5	T6	T7	T8

d								
D = $\frac{d}{2}$								
F								
t								
S								
HZ								
HZK								

d (mm) Cutter dia.
 D (mm) Cutter radius
 F (mm/min) Feed speed
 t (mm) Max. milling depth
 S (U/min) Spindle speed
 Hz (mm) Difference measure
 Hz_K (mm) Corrected difference measure

Vertical axis system

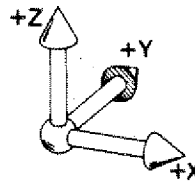

Horizontal axis system

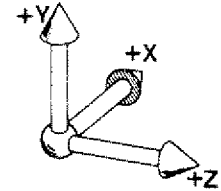

Zero-point of workpiece
 Start position
 Tool change position

Zero-point offset (G92)

X _____ mm

Y _____ mm

Z _____ mm

Drawing no.:
 Denomination:
 Workpiece material:
 Program no.
 Name:
 Date:

