

Instruction book
Service parts
EMCO F1-CNC/P

CNC MILLING

Edition 3/88

EMCO

Order No. EN 7709

INDEX

General

- Introduction	I
- Safety recommendations	II
- Technical data of machine	III
- Technical data EMCOTRONIC M1	IV
- Structure of G codes	V
- The M codes	VI

1. Erection of the machine

1.1 Machine acceptance	1/1
1.2 Scope of delivery of the basic model	1/1
1.3 Dimensions	1/2
1.4 Transport, erection of machine and control	1/3 - 1/5

2. Electrical connections

2.1 Power supply for the FIP-CNC	2/1
2.2 Mains supply	2/2
2.3 Machine-control connection	2/3
2.4 Fuses	2/4
2.5 Layout diagram	2/5
2.6 Electrical connection of the accessories	2/6
2.7 Changing the stepping motor printed circuit board R3D 413 000	2/7

3. Description of the machine

3.1 Description of the design	3/1
3.2 Machine zero point, tool-holding fixture reference point	3/2

4. Commissioning of the machine

4.1 Switching on the machine	4/1
4.2 Approaching the reference point	4/2
4.3 Switching off the machine	4/3

5. Accessories for clamping the workpieces

5.1 Clamping tools for workpieces	5/1 - 5/2
5.2 The dividing attachment	5/3 - 5/6

6. Tools - Tool data

6.1 Clamping of tools	6/1 - 6/2
6.2 Tool programming and compensation	6/3 - 6/5
6.2.1 T-address	6/3
6.2.2 Call-up	6/3
6.2.3 Cancellation of the tool (length) compensation	6/4
6.2.4 Alarms	6/4
6.2.5 Tool compensation values	6/4
6.2.6 Input - Compensation	6/5
6.2.7 Programming note	6/5
6.3 Correction of tool length compensation	6/6 - 6/7
6.4 Direct take-over of tool lengths	6/8 - 6/9

- 6.4.1 Touching with dial gauge 6/8
- 6.4.2 Scratching a trial workpiece 6/9

7. Technological data

- 7.1 General 7/1
 - 7.1.1 Cutting speed (V_s) 7/1
 - 7.1.2 Speed (S) 7/1
 - 7.1.3 Feed rate (F) and depth of cut (t) 7/1
- 7.2 Determining the feed rate and depth of cut during milling 7/2 - 7/3
 - 7.2.1 Face milling of aluminium (Torrador B) at $v = 44$ m/min 7/2
 - 7.2.2 Face milling of steel (9S20) at $v = 35$ m/min 7/3
- 7.3 Determining the feed rate during drilling in 9S20 and Torrador B 7/4
- 7.4 Determining the speed and cutting speed 7/5

8. Lubrication of the machine

- Lubricant recommendations 8/1 - 8/2

9. Re-adjustment work - in preparation

10. Spare parts list - in preparation

Introduction

These operating instructions contain machine-specific information.

Erection of the machine, electrical connections, accessories, instructions, technological data, maintenance and re-adjustment work.

The description for the programming and operation of the control are to be found in the programming instructions and the operating instructions EMCOTRONIC M1.

The basic features can vary and therefore possible accessories are not marked as such. For the exact scope of delivery of the basic model, see brochure or quotation.

The instructions:

It is assumed that the operator of the machine knows how to clamp the workpieces and tools correctly and securely.

It is further assumed that the user is capable of selecting the correct tools and cutting data for the operation in question.

Safety Recommendations

- * Observe the general safety rules for machine tools and CNC machine tools.
- * Only qualified and authorised persons are allowed to use the machine. It has to be protected against unauthorised operation (remove switch key).
- * In case of emergency use emergency-off button.
- * Do not interfere with the electrical part of the machine. If you change control devices, any warranty claim will become invalid.
- * Do not operate the key-operated switch while the machine is running.

Technical data of machine:

Working range:

Slide path, longitudinal (X)	200 mm
Slide path, transverse (Y)	100 mm
Slide path, vertical (Z)	200 mm
Milling head swivelled from vertical to horizontal	90°

Milling table:

Table area	420 x 125 mm
No. of T-slots	2
Slot width/spacing	11/90 mm

Distance between milling spindle and milling table:

Vertical	25 - 225 mm
Horizontal	80 - 280 mm

Milling spindle:

Tool mounting similar to DIN 2079	SK 30
Tool clamping rapid-action clamping feature	
Working radius	140 mm

D.C. motor:

Motor rating	550 W at 4000 rpm
Speed of main spindle	150 - 4000 rpm infinitely variable

Feed drive:

Stepping motor	
Ball screws	
Feed rate in CNC mode	1 - 1200 mm/min
Step resolution	0.001 mm
Feed force	1300 N
Rapid traverse	1200 mm/min

Weight of the machine:

120 kg

Weight of the control:

95 kg

Technical Data

EMCOTRONIC M1

Microprocessor 3-axis-contour control
Linear and circular interpolation (2 1/2 D)
Program memory for minimum 100 m tape.

Actual position
Distance left to traverse
Spindle rpm
Tool compensation
Feed
Further parameters
9" Monitor black/white

Input accuracy	0,001 mm (0,0001 inch)
Thread pitches (tapping)	0,01 - 32 mm
Feed override	0 - 140 %
Spindle rpm override	50 - 120 %
Range of interpolation	±9999,999 mm
Tool memory	99 tools

Modes of Operation

Manual mode (manual traversing of slides)
Execute (working off the input memory)
Edit (program input via keys, interfaces)
Reference point (approaching the reference point)
Automatic (Working off NC-programs)

Submodes

Single block, skip block, dry run

Program Formats

Structure according DIN 66025 (= ISO 1056)
Decimal point input

The Addresses

O Program number (00 - 99)

N Block number (0000 - 9999)

G Codes (00 - 99)

G00 = Rapid traverse
G01 = Linear interpolation
G02 } Circular interpolation
G03 }
G04 = Dwell
G17 = 1st Switching of axis
G18 = 2nd Switching of axis
G19 = 3rd Switching of axis
G20 = 4th Switching of axis
G21 = 5th Switching of axis
G22 = 6th Switching of axis
G25 = Subroutine call
G27 = Unconditional jump
G40 = Neutralization of the cutter tool correction
G41 = Cutter path correction left hand
G42 = Cutter path correction right hand
G53 = Position shift offset 1 and 2 erase
G54 = Position shift offset 1
G55 = Position shift offset 2
G56 = Position shift offset 3, 4 and 5 erase
G57 = Position shift offset 3
G58 = Position shift offset 4
G59 = Position shift offset 5, also changeable in
program

G70 = Measurements in inch
G71 = Measurements in mm
G81 = Drilling, centering
G82 = Drilling, spotfacing
G83 = Deephole drilling with withdrawal
G84 = Threading
G86 = Deephole drilling with chip breaking
G87 = Pocket milling cycle
G92 = Set Register
G94 = Data of feed speed in mm/min
inch/min
G95 = Data of feed in mm/rev.
G98 = Withdrawal to starting plane
G99 = Withdrawal to withdrawal plane

X, Y, Z Absolute coordinates

U, V, W Incremental coordinates

I, J, K Interpolation parameters

P0...P7 } Auxiliary parameters
D0...D7 }

F Feed in mm/min
μm/revolution
Thread pitch in μm

S Spindle speed

T Tool call-up, tool correction (four digits)

L Subroutine number/repetitions (four digits)

jump target

M (00 - 99)	Auxiliary codes
M00	Programmed stop
M03	Spindle clockwise direction
M04	Spindle counterclockwise direction
M05	Spindle stop
M08	Coolant on
M09	Coolant off
M17	Subroutine end
M30	Program end with return to program start
M38	Precise stop on
M39	Precise stop off

Permanent program memory for machine data, tool data position shift register and workpiece programs, position shift register.

Data Input/Edit

RS 232c interface (V24 and 20 mA), 150 - 2400 bd
tape recorder (Phillips MDCR) 600 signs/sec. (corresponds to 6 kbaud)

We reserve the right to make technical modifications and amendments !

Structure of G-Codes

Group 0		G00: Rapid traverse G01: Linear interpolation G02: } Circular interpolation G03: } * G04: Dwell G81: Drilling, centering G82: Drilling, spotfacing G83: Deephole drilling with withdrawal G84: Threading G86: Deephole drilling with chip breaking G87: Pocket milling cycle
Group 2	**	G94: Data of feed speed in mm/min (inch/min) G95: Data of feed in mm/rev. (inch/rev.)
Group 3	**	G53: Position shift offset 1 and 2 erase G54: Position shift offset 1 G55: Position shift offset 2
Group 4	*	G92: Set Register
Group 5	**	G56: Position shift offset 3,4 and 5 erase G57: Position shift offset 3 G58: Position shift offset 4 G59: Position shift offset 5 (also changeable in program)
Group 6		G25: Subroutine call G27: Unconditional jump
Group 7	<input type="checkbox"/>	G70: Measurements in inch <input type="checkbox"/> G71: Measurements in mm
Group 8	**	G40: Neutralization of the cutter tool correction G41: Cutter path correction left hand G42: Cutter path correction right hand
Group 9	<input checked="" type="checkbox"/>	G17: 1st Switching of axis <input type="checkbox"/> G18: 2nd Switching of axis <input type="checkbox"/> G19: 3rd Switching of axis <input type="checkbox"/> G20: 4th Switching of axis <input type="checkbox"/> G21: 5th Switching of axis <input type="checkbox"/> G22: 6th Switching of axis
Group 11	**	G98: Withdrawal to starting plane G99: Withdrawal to withdrawal plane

* Effective block by block

** Initial status

Initial status in mode of operation MON can be determined.

The M - Codes
Switching or Auxiliary Functions
(Structure)

Group		Remarks
Group 0	M03 Spindle clockwise direction M04 Spindle counterclockwise direction ** M05 Spindle stop	
Group 1	M38 Precise stop on ** M39 Precise stop off	
Group 2	* M00 Programmed stop * M17 Subroutine off * M30 Program end with return to program start	Effects also ● Coolant off (M09) ● Spindle off (M05) Effects additionally ● G40 Erase the cutter radius compensation ● Coolant off (M09) ● Spindle off (M05)
Group 3	M08 Coolant on ** M09 Coolant off	

* Effective block by block
 ** Initial status

1. Erection of the Machine

1.1 Machine acceptance

Inspections
Machine number
Control serial number

1.2 Scope of delivery of the basic model

1.3 Dimensions

1.4 Transport, erection of machine and control

1.1 Machine acceptance

- 1) The machine and the control should be checked for any transport damage. If damage is found, the dealer and the insurers should be contacted immediately.
- 2) Check that the delivery is complete - contact the dealer if any items are missing.
- 3) Machine number

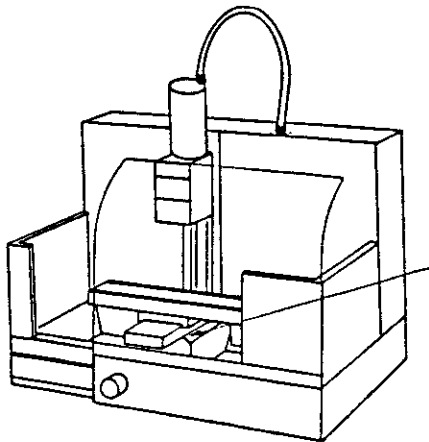

Quote the machine number in the case of complaints and spare parts orders.

- 4) Control serial number

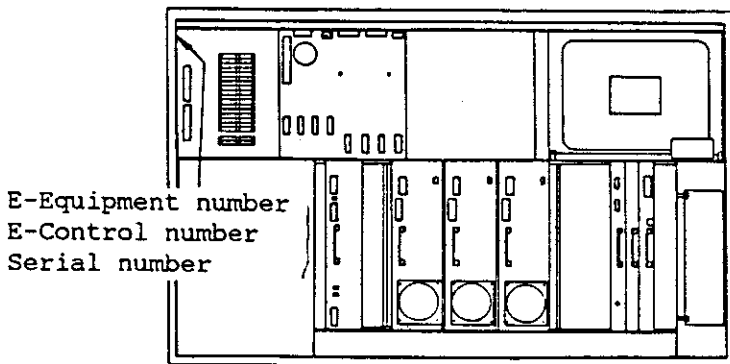

In the case of spare parts orders or complaints also quote the elec. equipment number, the elec. control number and the elec. serial number.

1.2 Scope of delivery - basic machine

Machine:

Coordinate table, vertical column with milling head, drive motor, stepping motors, sheet metal enclosure, transparent cover.

CNC control: EMCOTRONIC M1

Tools: collet chuck ESX-25 (9-10 mm clamping range), collet holder, table clamping rail, slotting-end mill \varnothing 10 mm,

1.3 Dimensions

Dimensions F1 P-CNC

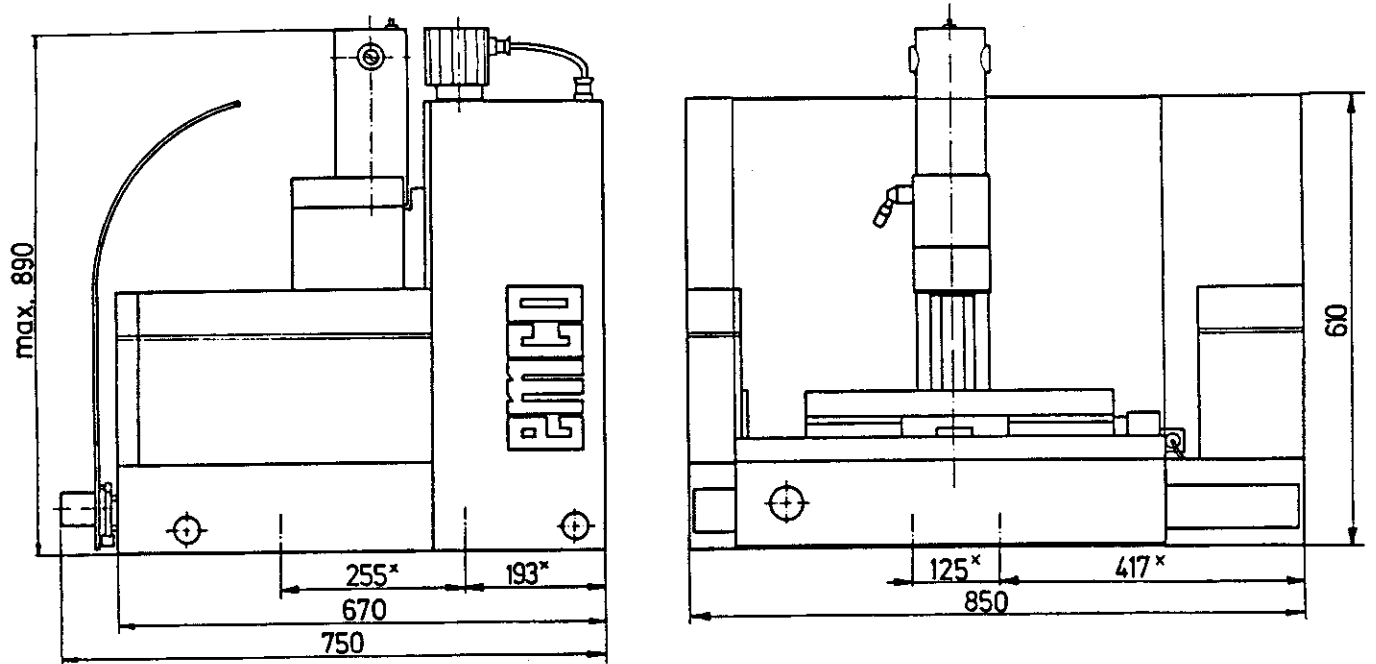

x... dimensions of the tapped bores M6 for bolting the machine.

Dimensions EMCOTRONIC M1

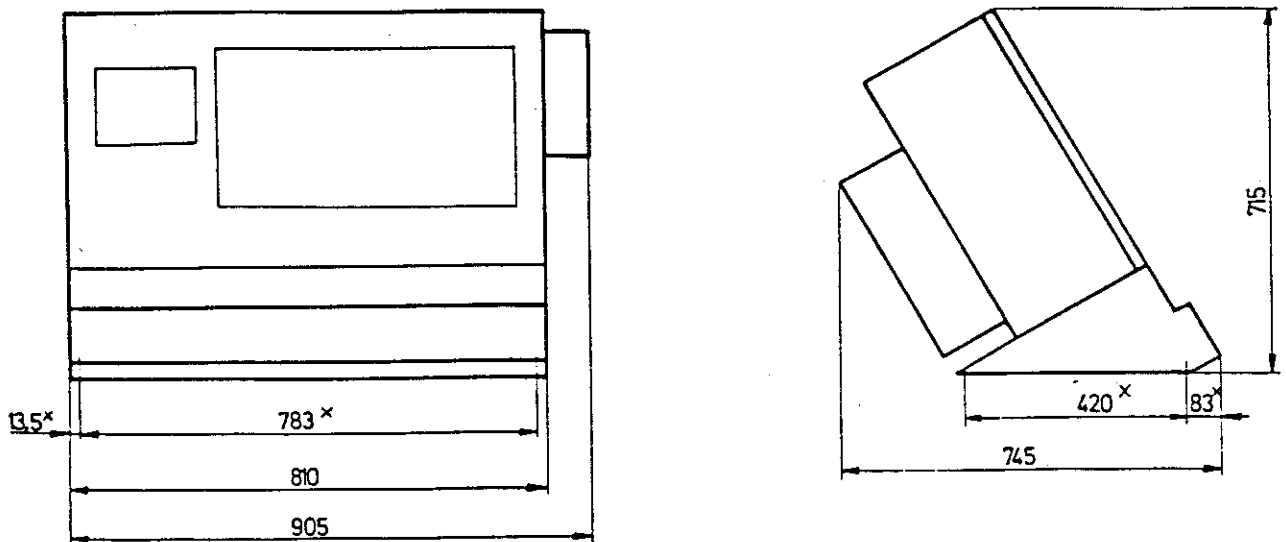

x... dimensions of the tapped bores M10 for bolting the control.

1.4 Transport and erection of machine and control

Weight of machine: approx. 120 kg

Weight of control: approx. 95 kg

Transport machine and control with bars,
max. 30 Ø mm.

Recommended length: approx. 1200 mm

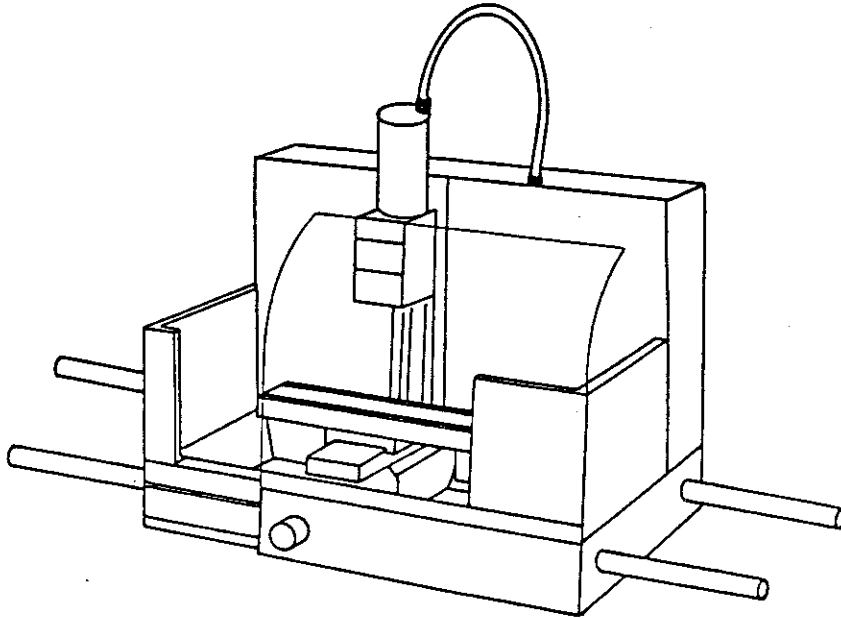

Machine and control bases

The machine and control must be mounted
on stable bases.

It is not necessary to bolt the machine
and control to their respective bases.

Recommended table sizes:

Machine:
length x width x height
1000 x 750 x 830 mm

Control:
length x width x height
810 x 500 x 830 mm

Recommended table height: 830 mm

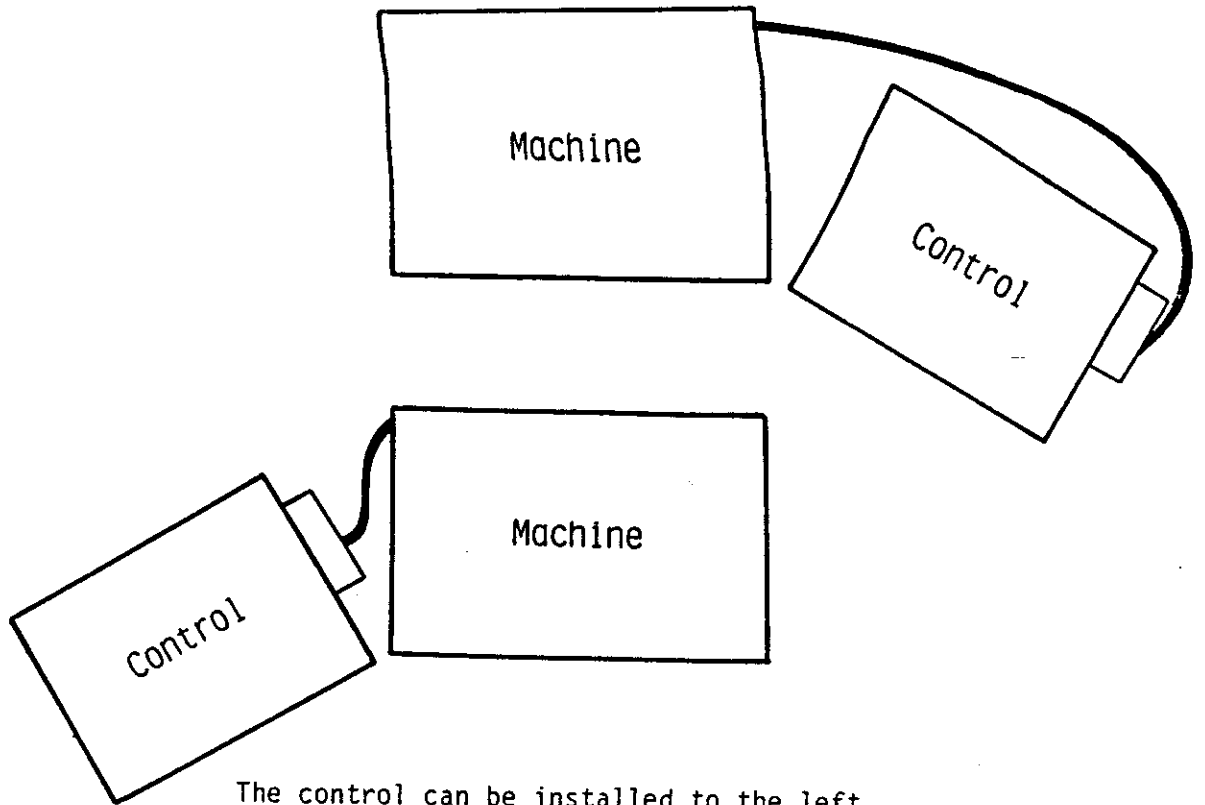

The control can be installed to the left or right of the machine.

Note:

Before commissioning, remove rust inhibitor and then grease and oil machine. See lubrication and oiling of the machine, chapter 8, point 1: Cross and longitudinal slideways.

Machine base for machine and control

The machine and the control can be turned through 120°.

Sizes of tables: See illustration

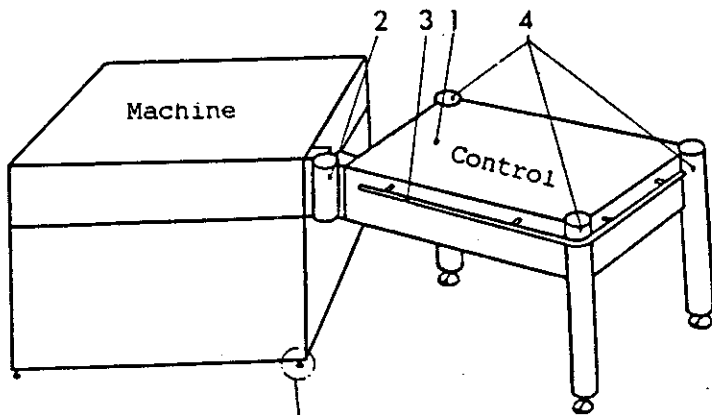
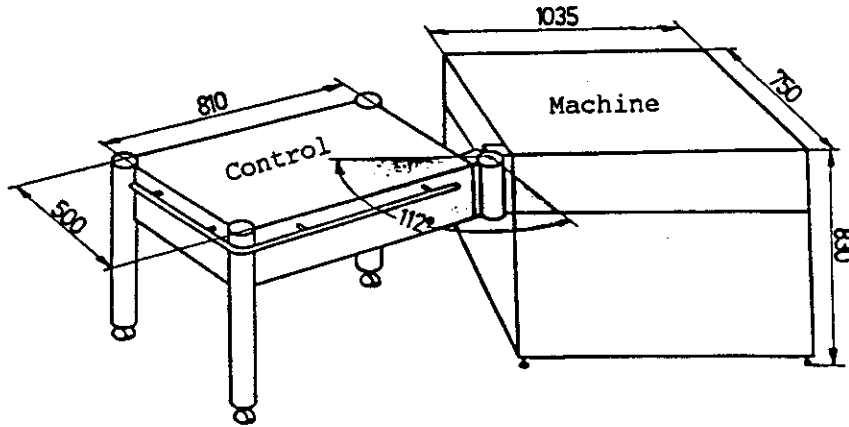

The stand for the control(1) can be mounted to the left or on the right side of the machine stand.

The joint(2), the handle(3) and the legs(4) have to be mounted in the correct way.

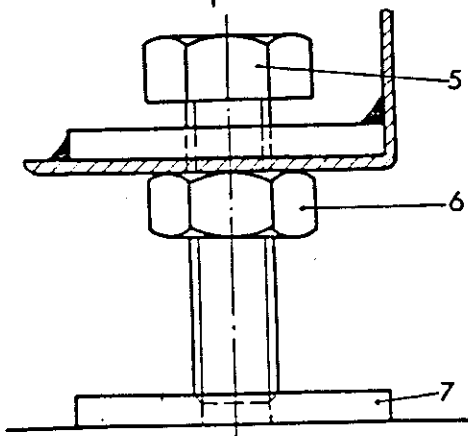

Adjusting the Height of the Machine Stand

- Adjust the height with the hexagon screws M16 x 60 (5).
- Counter the hexagon screw with the hexagon nut M16(6).

Note:

The hexagon bolts M16 x 60 can be placed directly on the floor, but it is advisable to place metal sheets (7) underneath.

2. Electrical Connections

- 2.1 Power supply for the F1P-CNC
- 2.2 Mains supply
- 2.3 Machine-control connection
- 2.4 Fuses
- 2.5 Layout diagram
- 2.6 Electrical connection of the accessories
- 2.7 Changing the stepping motor printed circuit board R3D 413 000

2.1 Power supply for the F1 P-CNC

Voltages: 100 V }
 115 V }
 220 V } single-phase
 240 V }

Frequency: 50 Hz or 60 Hz

Fuse: 10 A slow

Connected load: 700 VA

Lead-ins:
3 x 1.5 mm² wire cross section.

Please also observe the local
regulations!

2.2 Mains connection

Note:

Only a trained electrician may connect the machine.

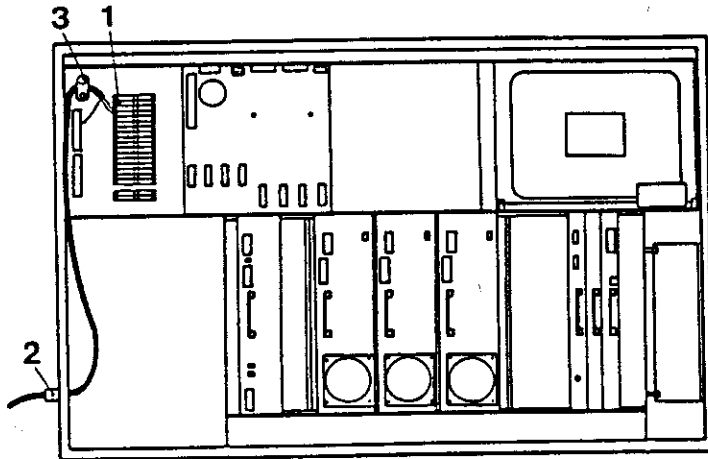

1. Terminal strip for mains connection
2. Screw fitting for mains cable.
3. Strain-relief clamp

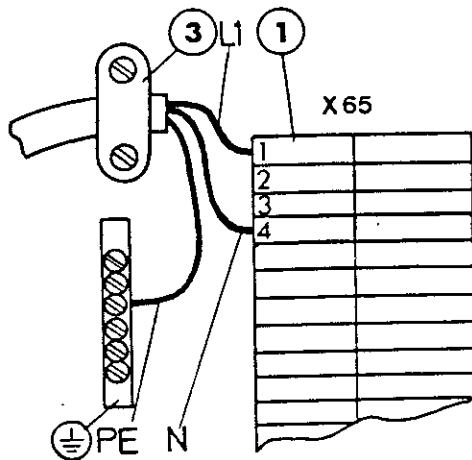

+ Unscrew cap of cable screw fitting (2) and thread onto lead-in.

+ Pass lead-in through cable screw fitting.

+ Connection:

- Connect phase L1 to contact 1 of the terminal strip X 65 (item 1).

- Connect neutral conductor N to the terminal 4 (blue terminal) of the terminal strip X 65 (item 1).

- Connect yellow-green core (PE) to the earthing terminal (⊥).

+ Clamp lead-in in strain-relief clamp (3).

+ Screw cap onto cable screw fitting (2).

2.3 Machine-control connection

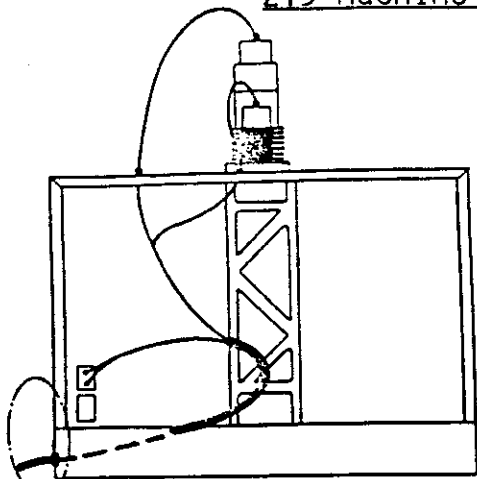

The cable lead is on the right or left of the machine housing depending on whether the control is located to the right or left of the machine.

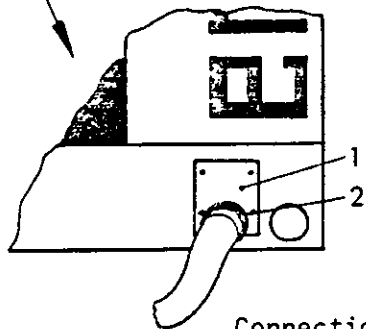

Remove metal plate (1), insert all plugs. Mount cable collar (2) on housing and secure with metal plate (1).

Connection of the machine cable to the control:

Warning !

When connecting or disconnecting, the main switch must be switched off otherwise electronic components can be destroyed.

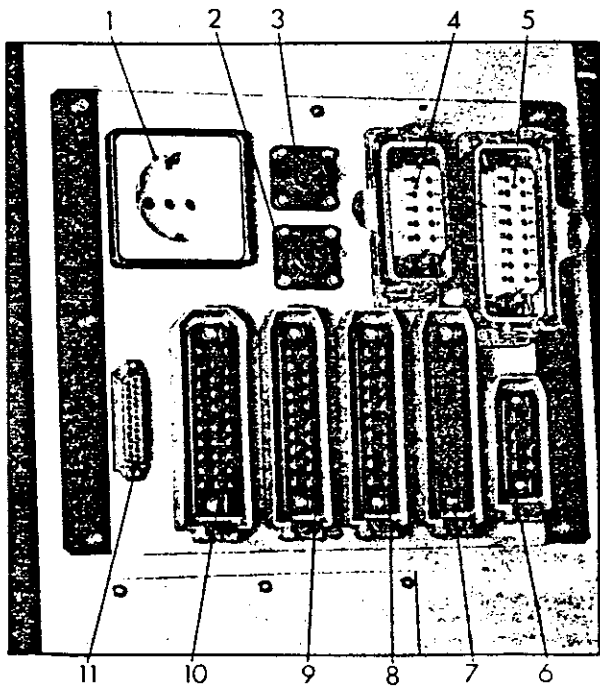

- 1 .. socket: mains voltage
- 2 .. el. vice (accessory)
- 3 .. speed transmitter
- 4 .. provided for extensions (power current), plug covered
- 5 .. main drive
- 6 .. tool turret
- 7 .. stepping motor Z
- 8 .. stepping motor Y
- 9 .. stepping motor X
- 10 .. door limit switch
- 11 .. interface RS-232 C

2.4 Fuses

1. Main drive fuse:

If the control lamps (1) do not illuminate on the main drive pc board, the main drive fuse (2) has probably blown (fuse type: glass-tube fuse 16 A ff, 6.3 x 32). The reason for this may be too high a fluctuation of the mains voltage (max. +/- 12 V admissible).

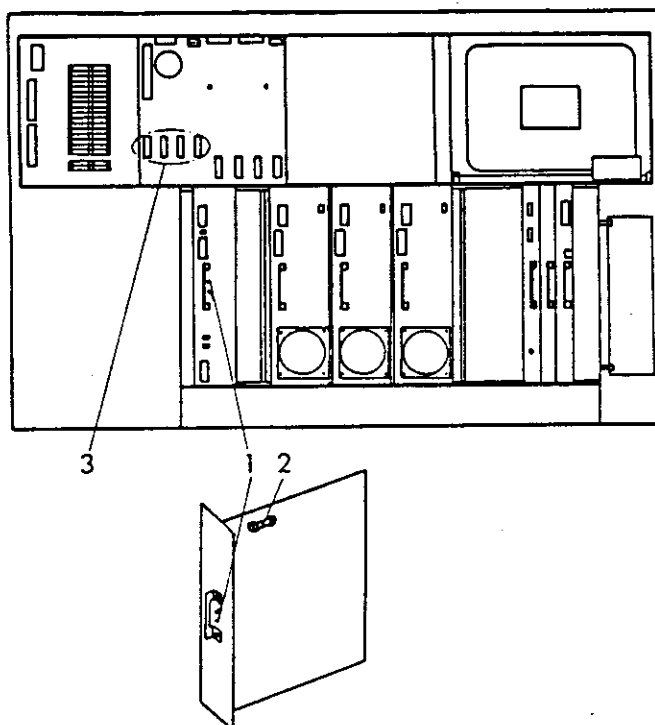

2. Fuses on the motor driver card (3)

from left to right, fuses for:
E11 ... socket
E12 ... plug, item 4
E13 ... power supply for computer
E14 ... transformer for drive X,Y,Z

- L1 failure lubricant
- L2 failure coolant
- L3 control 24V
- L4 control 12V
- L5 control 12V
- L6 control 12V
- L7 control 12V
- L8 control 12V
- L9 control 12V
- L10 control 12V
- L11 control 12V
- L12 overtemperature stop motor
- L13 overtemp stop motor
- L14 excess voltage stop motor
- L15 step motor control stop
- L16 under voltage stop motor
- L17 control voltage supply computer
- L18 alarm status
- L19 control ramping device
- L20 control ramping device
- L21 control lubrication pump
- L22 control lubrication pump

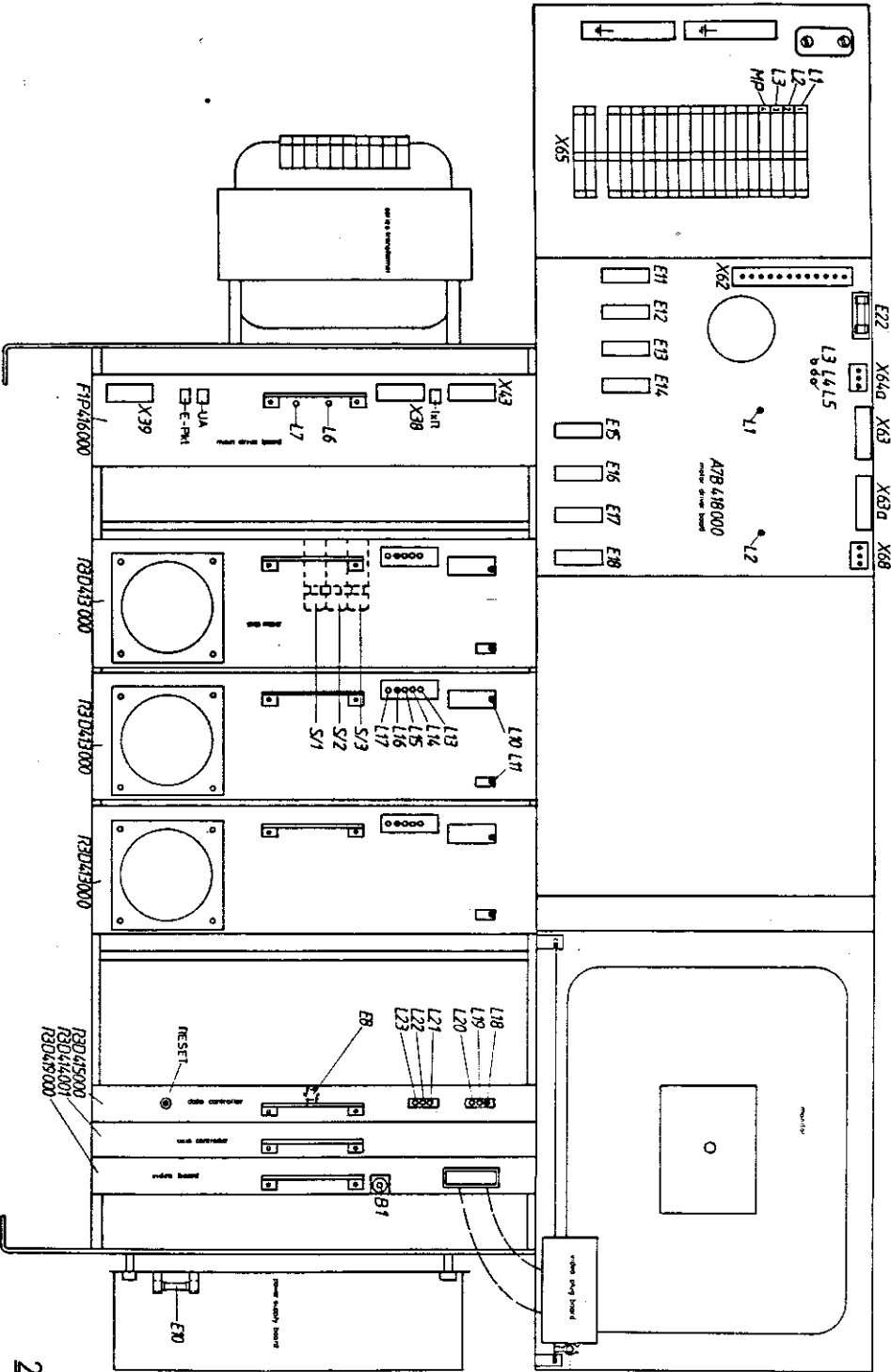

- E8 4A fast door control
- E9 2A medium power supply board
- E11 5A slow door
- E12 5A slow door

- E13 5A slow voltage supply computer
- E14 5A slow transformer load power
- E15 0A superfast lubrication pump
- E16 0A superfast control pump

- E17 0A superfast motor pump
- E18 0A superfast control pump
- E22 4A slow power supply for
- E23 12A slow motor

- S1 63A slow ramp motor
- S2 63A slow ramp motor
- S3 1A slow ramp motor

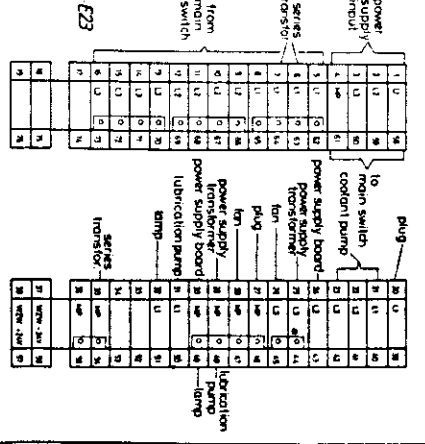

2.5 Layout diagram

EMCOTRONIC MI

2.6 Electrical connection of the accessories

Connection of the electric machine vice

Scope of delivery:

- vice with connection cable
- cable plate
- 2 printed circuit boards
- screws for mounting the pc boards

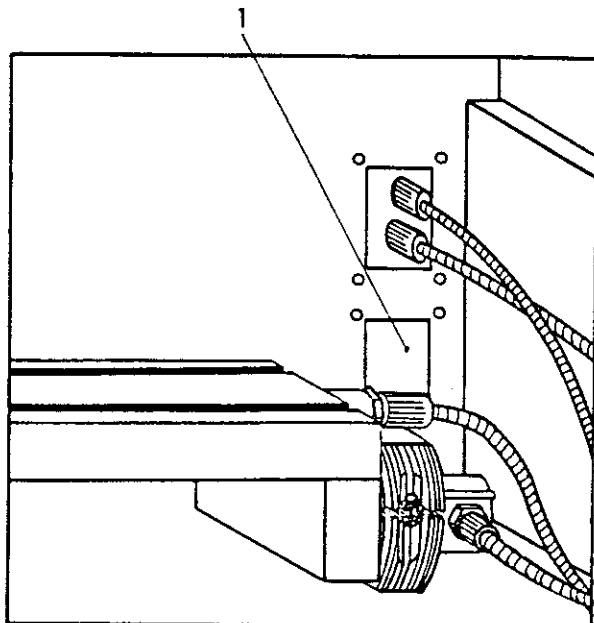

Installation:

- + Remove cover panel (1), insert connection cable of vice and mount cable plate supplied.
- + Open cable sheathing and insert connection cable.
- + Plug in plug for machine vice (see chapter 2.3)

PC board installation

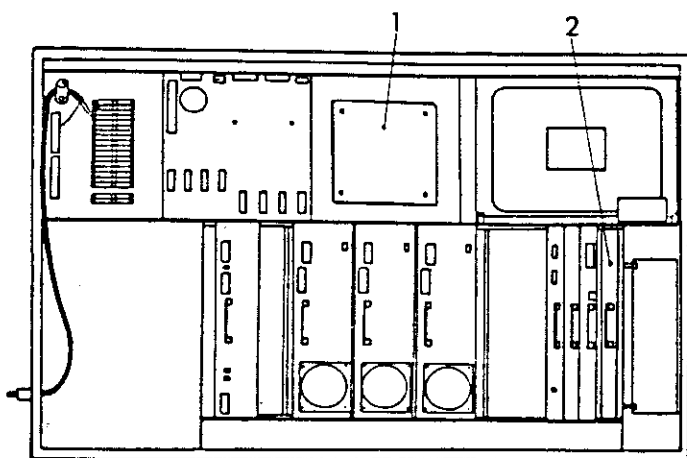

open control box

- + Mount board (1) with 4 cheese head screws and plug in the free Panduit plug.
- + Plug Panduit plug into board (2), insert board (2) and secure with 2 screws.

Warning !

When connecting or disconnecting, the main switch must be switched off as otherwise electronic components could be destroyed.

ATTENTION !!!

2.7 Changing stepping motor board R3D 413 000

Before mounting the board R3D 413 000 the dip-switches for current adjustment and feed directions have to be set in correct way. Otherwise the board will be destroyed.

Note: Dark means pressed = ON

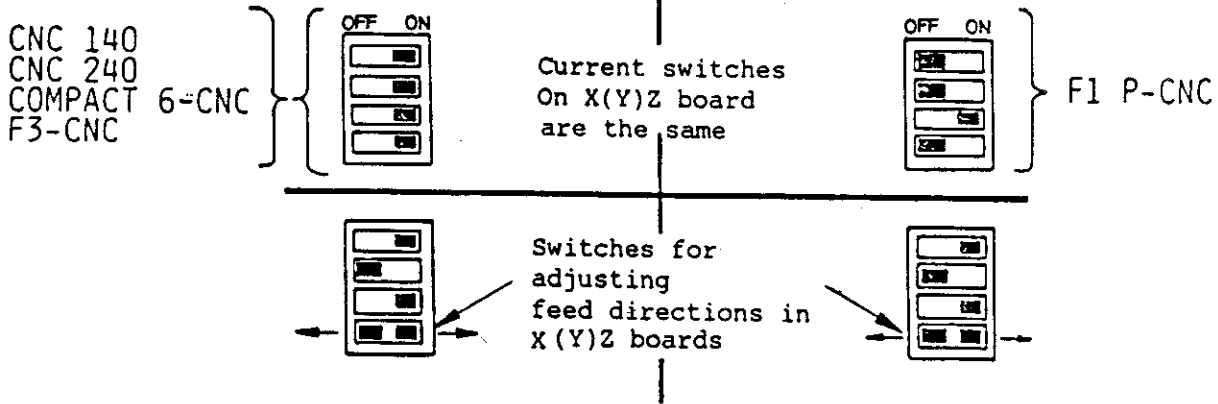

Adjusting feed directions

Note:

Dark means pressed = ON

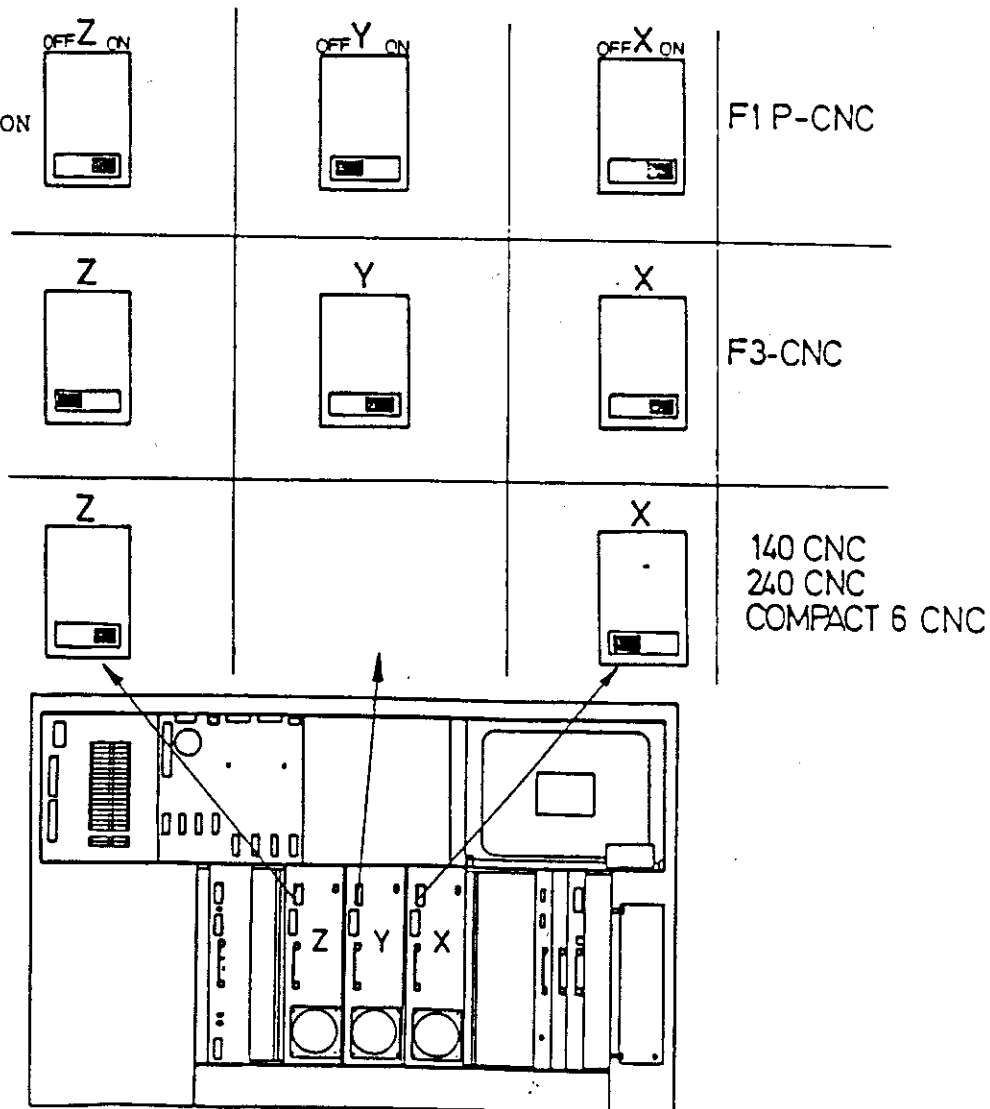

3. Description of the Machine

3.1 Description of the design

- Machine frame with integrated chip tray
- Machine stand
- The slides/guideways
- The axis drives
- The measuring system/control system
- The milling head
- The milling spindle
- The milling spindle drive
- The working area
- The machine data for vertical and horizontal milling
- Clamping tools

3.2 Machine zero point, tool-holding fixture reference point

3.1 Description of the design

Machine frame with integrated chip tray

The machine frame is mounted on the plastic-coated fabricated steel construction. The chip tray has a smooth finish and is therefore easy to clean.

Machine stand

The machine stand is manufactured from high-grade grey cast iron with heavy ribbing. This ensures high stability and vibration-free behaviour.

The slides/slideways

The slides are also made of high-grade grey cast iron. The slideways are designed as ground dovetail guides. Optimum guiding conditions of the slides and oversizing of the slideways ensure low surface pressure and thus a long service life. All slides are fitted with two adjustable taper gibs.

The axis drives

The slides are traversed with stepping motors via high-precision ball screw spindles.

Step resolution: 0.001 mm

High positioning accuracy is achieved with the rigid high-precision ball screw spindles (\emptyset 12 x 5 mm) and a rigid axial bearing arrangement.

The measuring system/control system

The position of the machine zero point (M) in relation to the tool-holding fixture reference point (N) is determined by the control when the reference point is approached. In traversing operations the slide positions are monitored every 5 mm (synchronous measurements: target/actual value comparison/slide travel with computer). Alarm is given if a drive falls out of step.

The milling head

The milling head can be swivelled through up to 90° after two hexagon head screws have been loosened. The 0° and the 90° positions are set as end stops.

Tool clamping

The tool-holding fixtures are clamped with a rapid-action clamping device by activation of the clamping lever. Ensure that the tool taper and main spindle cone are free of dirt and grease.

The milling spindle

The milling spindle is mounted in two tapered roller bearings, backlash-free. The tapered roller bearings have permanent grease lubrication.

Tool-holding fixture: SK30 similar to DIN 206.

Drive of the milling spindle

The milling spindle is driven directly by an infinitely variable d.c. motor via a toothed belt. The main spindle brake and reversal of the direction of rotation are activated by the control. The main spindle speed and slide feed are synchronised by a speed transmitter.

The working area

The working area is limited by the mechanical stops. To ensure that the slides do not become blocked, software stops are provided about 0.5 mm in front of the mechanical stops.

CNC operation

When slide paths are programmed in CNC operation which extend beyond the software stops, the control displays alarm 44: TARGET LIMITS EXCEEDED.

Manual operation

In manual operation the control displays alarm 45: ENTER CAUTION ZONE, about 5 mm before the software stops are reached. In this zone (5 mm before the software stop) the feed rate is automatically reduced so that there is still an adequate distance for braking. When the software limit switch is reached, the control displays alarm 44: TARGET LIMITS EXCEEDED.

The machine data for vertical and horizontal milling

When the machine is converted from horizontal to vertical milling, the position of the tool-holding fixture reference point and the coordinate system change. The MSD data must be loaded (see programming instructions and operating instructions EMCOTRONIC M1). The machine is delivered with the MSD data for vertical milling.

3.2 Machine zero point

Tool-holding fixture reference point

NOTES FOR BETTER COMPREHENSION

- 1) The machine manufacturer establishes the position of M and N on the machine.

Criterion for establishing the position M :

It must be easy to determine the distances to the workpiece zero point.

- 2) The machine manufacturer measures the distances from M to N and enters them into the control (This measuring procedure is performed when the reference point has been approached). The control therefore knows the distances M to N.
- 3) Vertical and horizontal milling
The distances from M to N differ for vertical and horizontal milling. With a universal milling machine, such as the FIP-CNC, the MSD data of the control therefore have to be changed when the machine is converted.

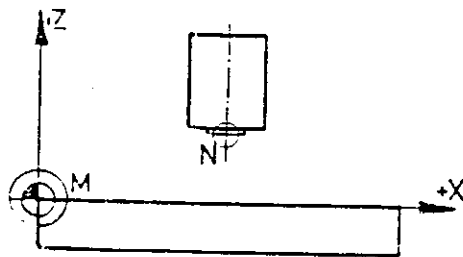

FIP-CNC
vertical

Position of M:
Left front edge of the
table surface

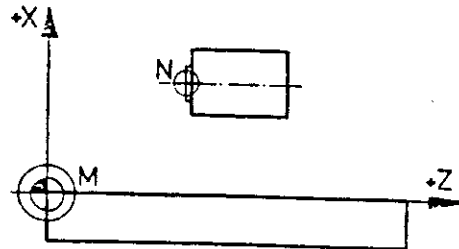

FIP-CNC
horizontal

Position of N:
N lies in the spindle axis at
the front of the main spindle.

MSD data

The machine is delivered with two cassettes and two punched tapes with MSD data.

* MSD data vertical milling

* MSD data horizontal milling

The relevant data must be entered depending on the alternative selected.

Condition of delivery FIP-CNC

MSD data for vertical mode of operation have been loaded.

4. Commissioning of the Machine

- 4.1 Switching on the machine
- 4.2 Approaching the reference point
- 4.3 Switching off the machine

4. Commissioning of the Machine

- Remove corrosion inhibitor
- Ensure that workpieces and tools are clamped firmly and securely.

4.1 Switching on the machine

Activate main switch (key-operated switch). The emergency-off button must be unlocked. The control reports in the MANUAL mode. The reference point must be approached (see page 4/2).

Note:

If the machine has not been switched on for more than 3 months, the MSD data (machine status data) are no longer available in the buffer memory. In this case the screen displays alarm 13.

Moreover, nonsensical values are displayed in the position shift offset register (PSO) and in the tool data register (TO).

Measures:

Reload machine data from cassette or punched tape.

Loading of the machine data (MSD)

MSD is an abbreviation for "machine status data".

The machine is delivered with one machine data cassette and one punched tape with the MSD data.

1. Loading machine data - from cassette:

Insert cassette

EDIT

INT **O** **ENTER**

M **S** **SHIFT** **D**

INP

The data are loaded.
When the loading process is completed, the control reports with MAN.

2. Loading machine data from punched tape via RS 232C.

Insert punched tape.

EDIT

INT **I** **ENTER**

M **S** **SHIFT** **D**







INP

After loading press RESET.

This loading procedure must be performed three times.

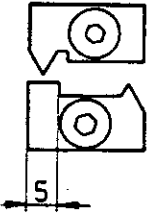
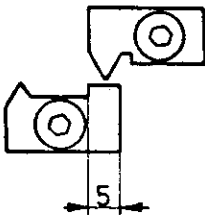
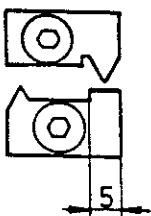
4.2 APPROACHING the reference point

The reference point serves to synchronise the measuring system. It must be approached in X, Y and Z every time the machine is switched on. After the reference point has been approached, the machine can be switched over to the other modes.

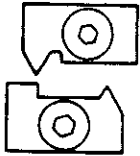
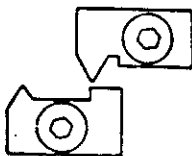
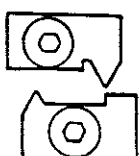
Sequence	Description	Check
 + 	Press key  and corresponding movement key together until the pointer is inside the rectangular area (5mm). Repeat the same procedure for the Y- and Z-axes.	   X-axis Y-axis Z-axis
	Switch over to operating mode "Reference point".	
	Select X axis.	
	After the  key has been pressed, the slide travels in such a way that the pointer lies at the inside corner. Repeat the same procedure for the Y- and Z-axes.	   X-axis Y-axis Z-axis

Note 1:

If, for example, after the positioning of only one arrow, you have pressed



you must switch back to the MAN. mode so that you can also traverse into the reference zone in the Y and Z directions.

Note 2:

From software version AC 02.00, DC 02.00 onwards you only need to press CYCLE START after the slides have been traversed into the reference zone. All three slides traverse to the reference point.

4.3 Switching off the machine

It is useful if you move the slides to the reference marks before switching off the key-operated switch.

When you switch on again you can move the slides only at low speed until you have approached the reference point.

Switching OFF the machine is performed with the key-operated switch.

Attention !

Key-operated switch must be used only when main spindle is at complete standstill. Otherwise the anchor fuse of the main motor may burn through.

5. Accessories for clamping the workpieces

5.1 Clamping tools for workpieces

5.2 The dividing attachment

5.1 Clamping tools for workpieces

Dimensions of the T-slots

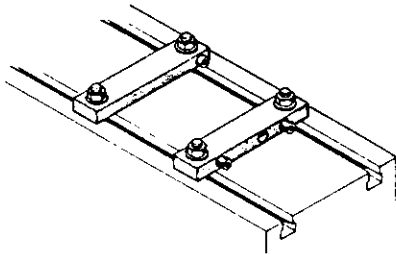
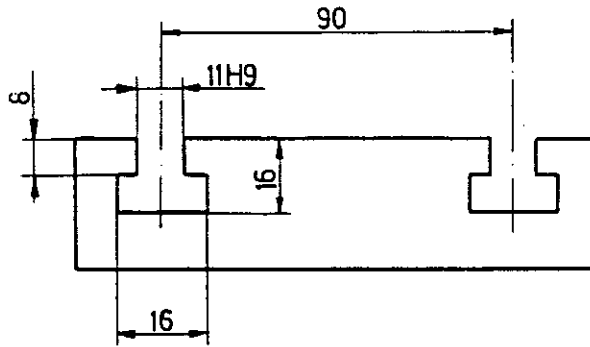

Clamping bars (basic equipment)
The clamping bars are mounted directly onto the slide depending on the workpiece in question. The workpiece is clamped with the stud bolts.

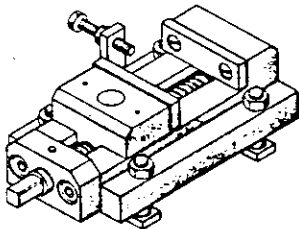

Machine vice with stop

Width of jaw : 60 mm
Clamping capacity: 60 mm

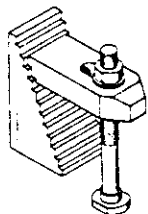

Incremental strap

Height: 60 mm
For clamping a workpiece you need at least two incremental straps.

3-jaw chuck (2 x 3 Jaws)

For holding round, triangular and hexagonal workpieces centrally.

4-jaw chuck (2 x 4 jaws)

For holding round, square and octogonal workpieces centrally.

4-jaw independed chuck

For holding workpieces centrally and eccentrically.

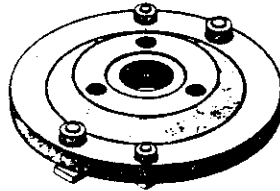
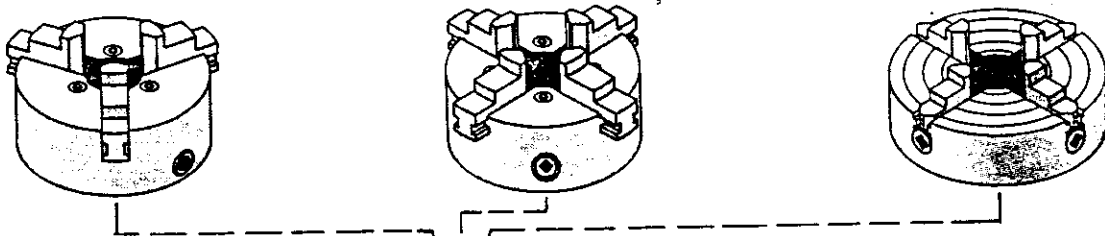

Adaptor plate

To mount 3-jaw, 4-jaw chuck and independent. The adaptor plate itself is mounted on to the milling table.

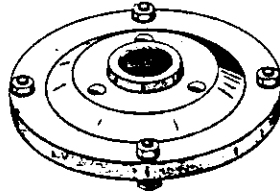
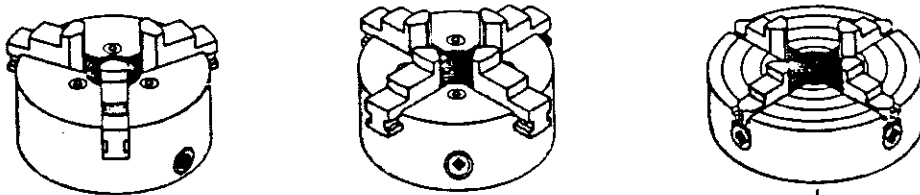

Intermediate plate

To mount 3-jaw, 4-jaw chuck and independent. The intermediate plate itself is mounted on to the dividing attachment. The dividing attachment is clamped to the milling table with two T-slot screws.

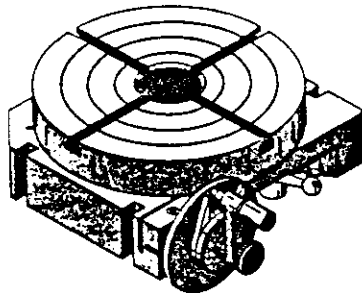

Dividing attachment

Operating instructions

TECHNICAL DATA

Diameter of rotary table: 150 mm

Worm reduction: 1 : 40

T-slots according to factory standard.

No. of holes in dividing plates:
27, 33, 34, 36, 39, 40, 42

OPERATING ELEMENTS

Clamping levers (1) for rotary table:

The clamping levers (1) must be clamped before every machine operation.

Indexing pin with handle (2):

During direct dividing from 15° to 15° the pin engages the indexing wheel. During indirect dividing or free dividing by means of the graduated scale, the handle must be pulled out and swivelled to the left.

The graduated scale (3) is for controlling the divisions.

Crank handle with index plunger (4) is connected to the worm which in turn engages the indexing wheel.

The shears serve to facilitate adding the number of holes when a fraction of a turn is made.

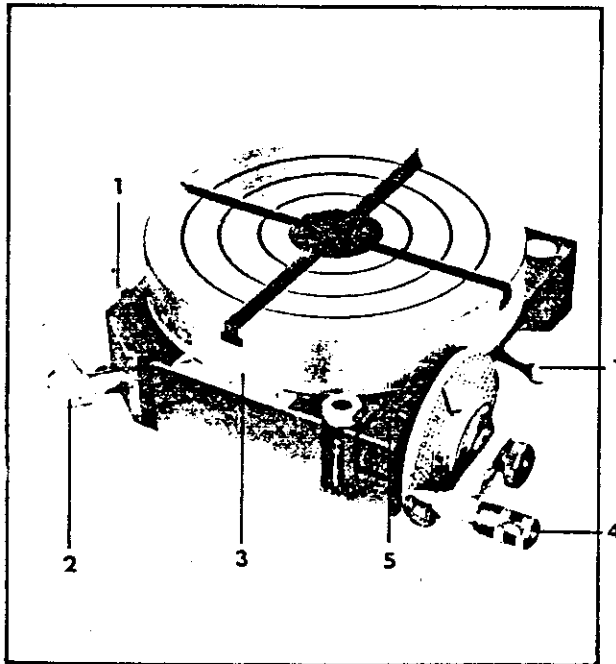

T-slots of the dividing attachment

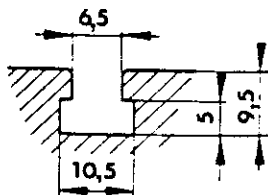

Disengaging and engaging the worm:

The Allen head screw (5) is loosened. When the dividing plate is turned counterclockwise, the worm is disengaged. By turning the dividing plate clockwise, the worm is engaged for indirect dividing. To facilitate engagement of the worm, the rotary table should be moved slightly by hand. The indexing pin (2) must be disengaged during this procedure.

The Allen head screw (5) must then be retightened.

Types of dividing

Indirect dividing:

Indirect dividing is the more accurate dividing procedure as the worm reduction of 1 : 40 reduces inaccuracies in dividing.

Indirect dividing method:

Owing to the worm reduction of 1 : 40 the crank handle has to be turned 40 full revolutions before the rotary table turns through 360° . Exact fractions of turns can be made with the aid of the dividing plates.

Direct dividing:

The worm is disengaged and clamped.

Possibility 1:

Smallest dividing possibility from 15° to 15° .

(= 24 divisions per 360° revolution).

Note: The indexing pin must fully engage.

Possibility 2:

The indexing pin is pulled out and swivelled to the left. The dividing angle is set according to the graduated scale on the rotary table.

Note:

With indirect dividing the indexing pin is always disengaged. The rotary table must always be clamped before a work-piece is machined.

The indexing chart:

The 1st column indicates the number of divisions desired, the 2nd the number of degrees corresponding to the number of divisions. The 3rd column indicates the number of full revolutions which have to be made with the crank handle of the indirect dividing attachment for the corresponding number of divisions. The 8 other columns give the number of holes which have to be added to the full revolutions for each dividing plate.

Example of an indirect dividing operation:

Desired division: 13 divisions per 360° .

From the indexing chart it can be seen that at the desired division 13, 3 full crank turns must be made plus a fractional turn of 3 additional holes on the dividing plate 39.

Practical execution:

1. The dividing plate with 39 holes is mounted.

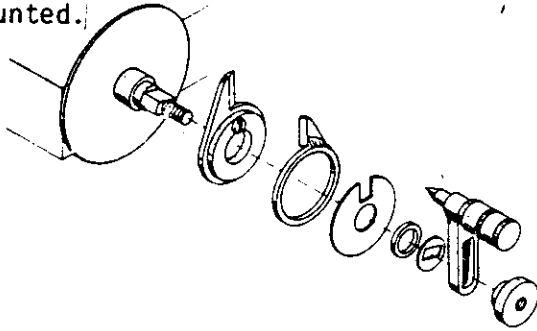

2. Fix the arms of the shears with the clamping screw so that 4 holes are visible (= 3 spaces).

The indexing chart contains the number of holes (= number of spaces) which have to be added. Thus, the arms of the shears encompass 4 holes when the number 3 is indicated.

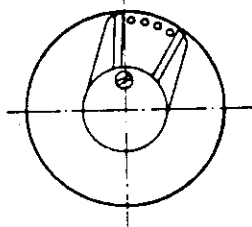

3. The indexing plunger is placed in a hole of plate 39 and the left arm of the shears moved until it touches the plunger.

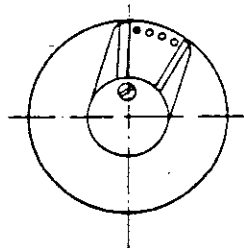

4. With the crank handle 3 full turns plus the fractional turn are made to the right arm of the shears. The plunger is inserted into the hole marked in black. One dividing operation is completed.

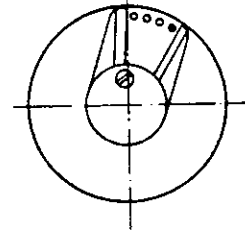

5. Next dividing operation: The shears are turned until the left arm touches the plunger again; the next dividing operation follows as described in 4. above.

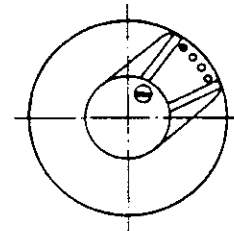

NOTE: The shears must not be moved during the dividing operation; otherwise they do not serve their purpose as an orientation aid.

Note:

If a larger number of holes has to be set than the maximum opening of the shears allows, you have to set the difference in the number of holes between the shears.

Example:

21 divisions per 360° have to be carried out. From the chart one can see that one full turn plus the fractional turn of 38 holes on the plate 42 have to be performed. 38 holes cannot be set.

Thus: $42 - 38 = 4$ holes. When dividing, you make one additional turn (2 turns altogether) and turn back the difference of 4 holes (5 holes are visible between the arms of the shears).

**INDEX TABLE
for
MAXIMAT**

Formula for the Calculation of the Hole Numbers Required
 z = No. of divisions required for one revolution of the workpiece.
 K = No. of revolutions of handle for a complete revolution of the workpiece.
 n = No. of revolutions of handle for one dividing move: $n = \frac{K}{z}$
 Worm reduction of dividing head 1 : 40; i. e. $K = 40$.

Division Desired	Degrees	No. of crank turns req'd	Amount of holes to be added for each index plate							Division Desired	Degrees	No. of crank turns req'd	Amount of holes to be added for each index plate															
			27	33	34	36	38	39	40				42	27	33	34	36	38	39	40	42							
2	180°	20								32	1							9									10	
	175°	19	12							33	1		7															
	170°	18	24							34	1				6													
	160°	17	21							35	1																	
	150°	16	18							36	10°	1	3					4										6
	140°	15	15							38	1									2								
	130°	14	12							39	1																1	
	125°	13	24							40	9°	1																
3	120°	13	9	11		12		13		42																		40
	110°	12	6							44						30												
	100°	11	3							45	8°		24															
4	90°	10								48																		35
	80°	8	24							50																		
	75°	8	9	11		12		13		52	7°		21															32
5	72°	8								54																		
	70°	7	21							55																		30
	65°	7	6							56																		
6	60°	6	18	22		24		26		60	6°		18															30
	55°	6	3							64																		
7		5								65																		25
	50°	5	15							66																		24
8	45°	5								68						20												
9	40°	4	12			16				70																		
10	36°	4								72	5°		15															24
11		3		21						76																		
12	30°	3	9	11		12		13		78																		
13		3						3		80																		
14		2								84																		
	25°	2	21							85																		
15	24°	2	18	22		24		26		88																		20
16		2				17	18	19		90	4°		12															
17		2				12				95																		
18	20°	2	6			8				96																		
19		2						4		100																		
20	18°	2								120	3°		9	11														16
	16°	1	21							180	2°		6															14
21		1								200																		
22		1		27						240																		8
24	15°	1	18	22		24		26		270																		7
25		1								360	1°		4															
26		1																										
27		1	13																									
28		1																										
30	12°	1	9	11		12		13																				

6. Tools - Tool Data

6.1 Clamping of tools

6.2 Tool programming and compensation

6.2.1 T-address

6.2.2 Call-up

6.2.3 Cancellation of the tool (length) compensation

6.2.4 Alarms

6.2.5 Tool compensation values: tool length and radius

6.2.6 Input - Compensation

6.2.7 Programming note

6.3 Correction of tool length compensation

6.4 Direct take-over of tool lengths

6.4.1 Touching with dial gauge

6.4.2 Scratching a trial workpiece

6.1 Clamping of Tools

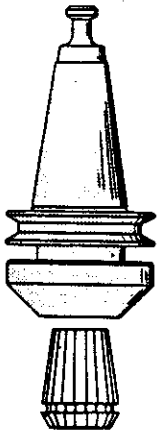

Attention:

Spindle taper and tool taper must be dirt- and dust-free.

Clamping with collet chuck

Tools with cylindrical shaft are clamped with the collet chuck.

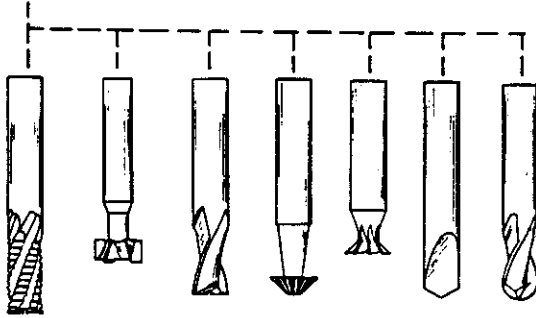

Note:

- Put collet into nut inclined so that the eccentric ring grips the groove of the collet. Screw nut with collet onto collet chuck.

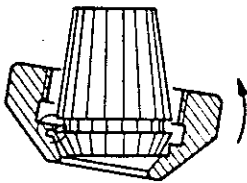

Clamping of tools

Put tool into collet and tighten nut with cylindrical pin in clockwise direction. For counter-holding of main spindle put cylindrical pin into collet holder.

Taking out the collet:

Unscrew nut. The eccentric ring in the nut presses the collet out the nut is unscrewed.

Maintenance

Use oil and clean collet and collet chuck after use. Chips and dirt can damage the tapers and influence the precision.

Collets

You find the clamping capacity in inch and metric engraved on the collets. Diameters smaller or larger than indicated must not be clamped.

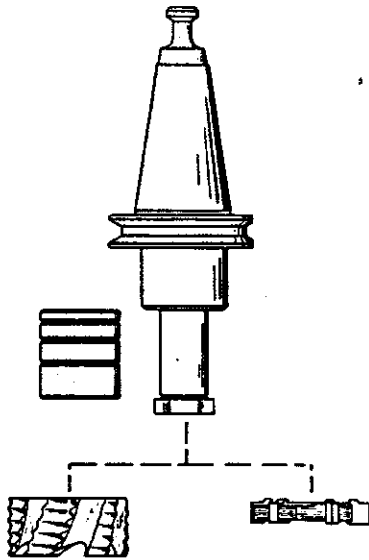

Clamping with shell end mill arbor

Using the arbor you can clamp tools up to a bore of 16 mm. The 4 spacing collars serve for adjusting the different width of the milling cutters.

Holder for taps

A separate description is enclosed with the holder for taps.

6.2 Tool Programming and Compensation

6.2.1 T-Address:

Tools are programmed under the T-address using a 4-digits number.

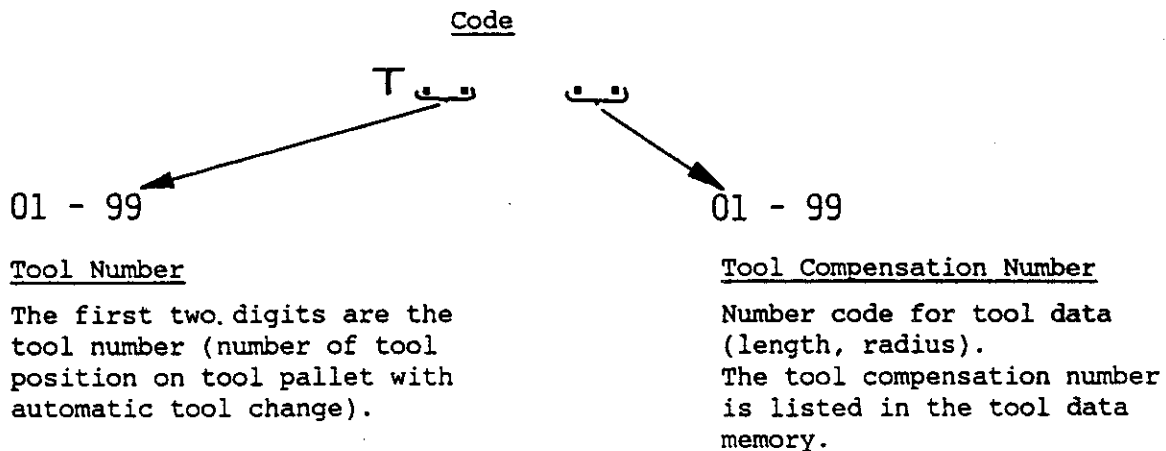

6.2.2 Call-up

Every new T-address has to be called-up with a G00 block (otherwise Alarm sign).

Example: Call-up in same block with G00

```
N 90 / M00  
N 100 / G00 / X.../Y.../Z.../ T02 02
```

Example: After the T-call-up a G00 traverse instruction follows.

```
N 100 / T02 02  
N 110 / G94 / F 130  
N 120 / G54  
N 130 / G00 / X.../Y.../Z.../
```

6.2.3 Calling-off the Tool(length) Compensation

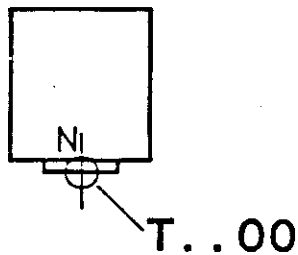

T.. 00

If the reference number T.. 00 is programmed, the coordinates (measurements) system refers to the reference point N of the tool-holding fixture

6.2.4 Alarms:

1. T-call-up not in connection with G00 traverse instruction
2. Unacceptable call-up T00 04:
Tool number \neq 1 - 99
But compensation number \neq 0
T 02 00 is acceptable, but does not make sense.

6.2.5 The tool compensation values

Tool length, tool radius

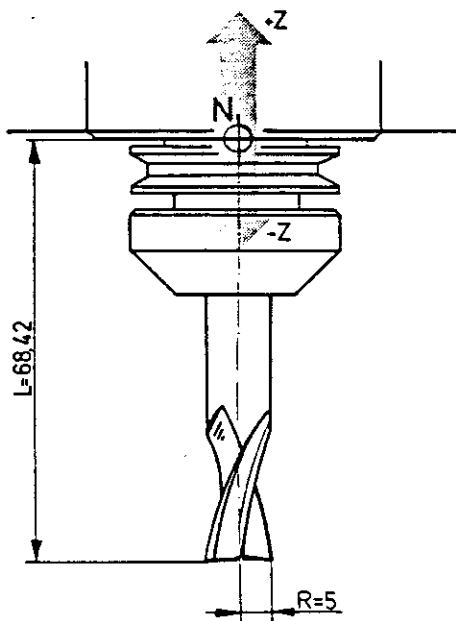

1. Tool length in mm (inch with G70 being active)with sign:

Imagine the coordinate system in point N. The tool lengths are taken from point N

2. Cutter Radius in mm (Inch with G70 being active)

The information on the radius is necessary with G41/G42.

Input:

Z - 68.42/R5

6.2.6 Input - Compensation

<u>MODE: EDIT TOOL DATA</u>				

	X	Z	R	L
0				
1				
2				
3				
4				
5				
6				
7				
8				
9				

The tool data are entered into the tool memory in the EDIT mode.

1 corresponds to compensation T.. 01
20 corresponds to compensation T.. 20

Tool lengths: under Z-address
Radius: under R.

Compensation:

If a tool is called up in the program, the control acquires the data Z (length) and R which are entered under the code number.

6.2.7 Programming Note:

Compensation number and tool number need not be the same, e.g. T05 01. For the sake of clarity it is advisable for the compensation numbers to be the same as the tool numbers.

6.3 Correction of tool (length) compensation

Correction of length measurements

By measuring the workpiece you find out possible faults, which are caused by non-accurate tool data.

Correction:

- * Erase wrong data
- * Enter correct data

Example:

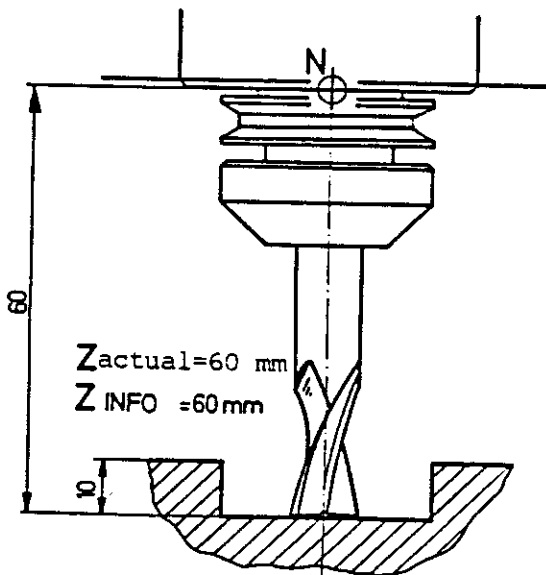

Z_{actual} is the same as
 Z_{INFO} in the tool data memory

Measurement in drawing (10) and on
workpiece must be the same.

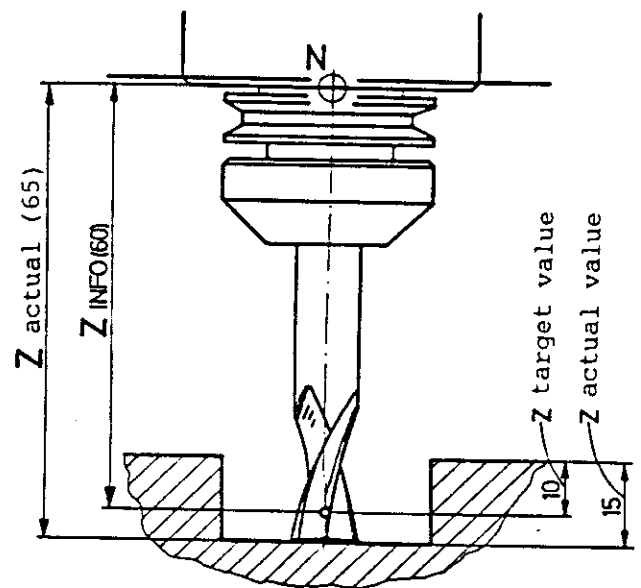

Z_{actual} is not equal to Z_{INFO} :
Consequence: Wrong measurements on
workpiece (15 mm instead 10 mm)

Correction of the length data

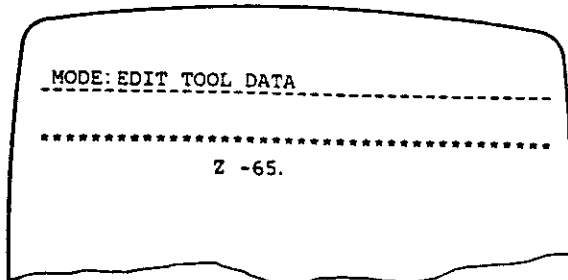
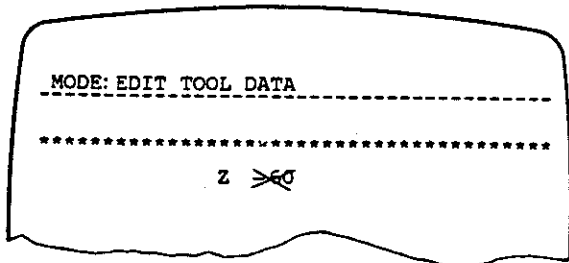
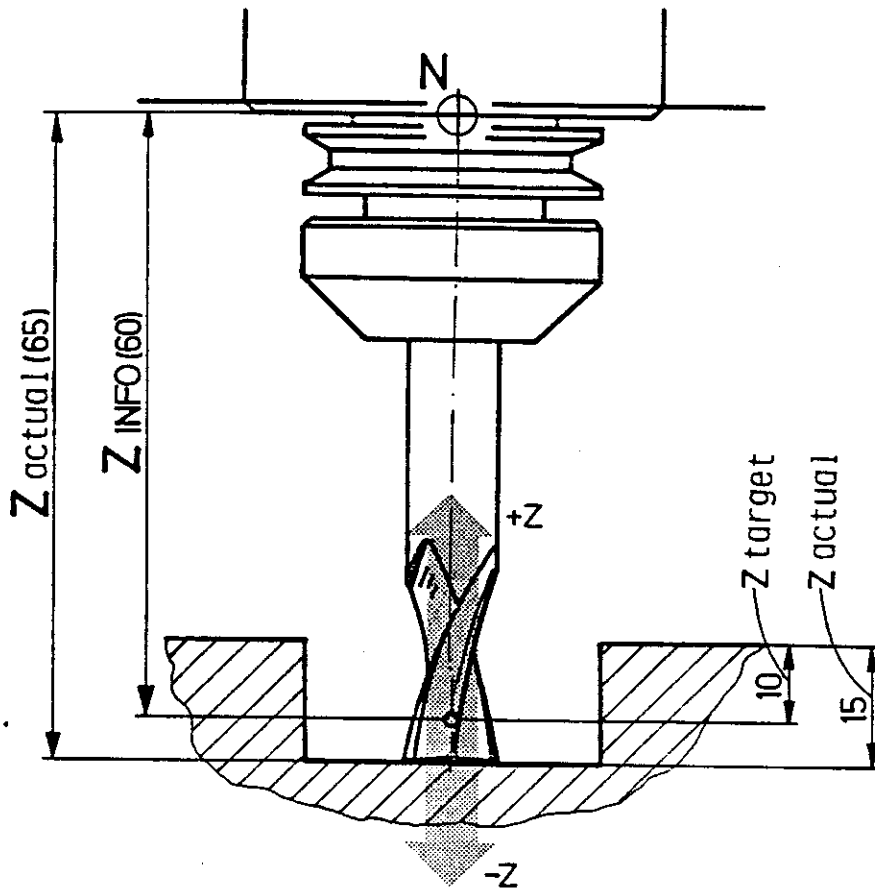

- * Imagine the coordinates system in the target value.
- * Measure difference between target value and actual value: $Z = -5\text{mm}$
- * Add this value with the correct sign to the value in the tool data memory.
 $Z - 60\text{ mm} + (-5\text{mm}) = -65\text{ mm}$
- * Write this value into the tool data memory.

6.4 Direct Take-over of tool length

This is very comfortable and can be made use of in most cases.

6.4.1. Touching with dial gauge

Mode
MAN

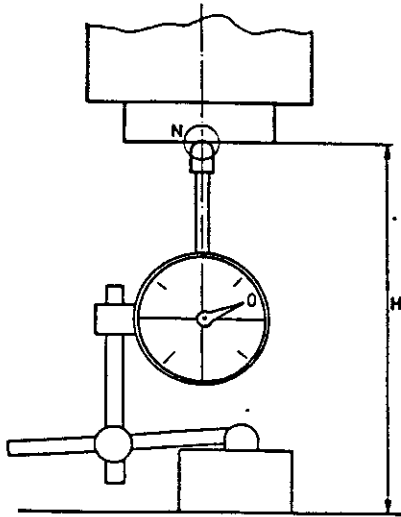

1. Touch dial gauge with point N.
Set dial gauge to zero.
If dial gauge indicates zero then a specific height H is reached.

SHIFT
T 0 0
ENTER

Height H is put in. The computer can now calculate the tool value Z when touching with a tool.

2. Touch dial gauge with tool (gauge must show zero, then height H is reached).

SHIFT
T 0 1 Tool number
ENTER

The measurement Z of tool T01 is entered under correction number T..01.

6.4.2 Scratching a trial workpiece

Mode
MAN

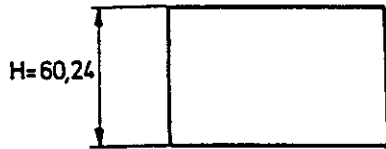

1. Measure the height (H) if the trial workpiece has to be scratched.

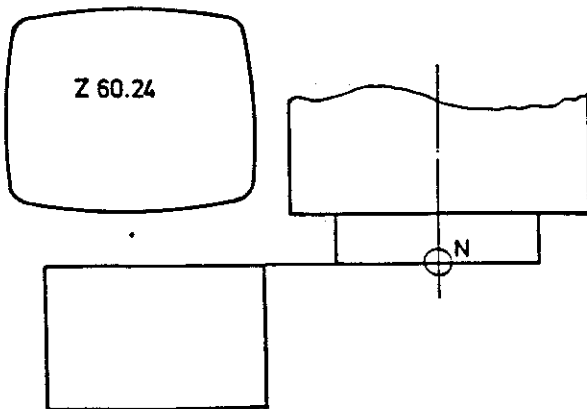

2. Move point N up to Z-value H (monitor read-out)

SHIFT
T 0 0
ENTER

The reference measurement H is registered.

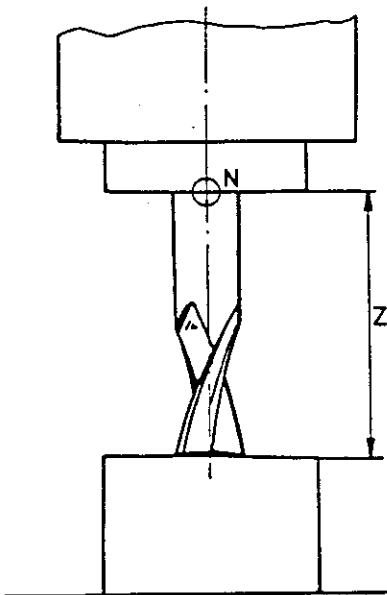

3. Scratch the surface of the workpiece.

SHIFT
T 0 1 actual tool number
ENTER

The measurement Z is registered under the correction number T..01.

7. Technological Data

7.1 General

7.1.1 Cutting speed (V_s)

7.1.2 Speed (S)

7.1.3 Feed rate, depth of cut

7.2 Determining the feed rate and depth of cut during milling

7.3 Determining the feed rate during drilling

7.4 Determining speed and cutting speed

Note:

The cutting values apply to well ground HSS tools. If softer or harder materials are cut than given in the tables, the cutting data are to be increased or decreased accordingly.

7.1 General:

7.1.1 Cutting speed (Vs)

$$V_s \text{ (m/min)} = \frac{d \text{ (mm)} \times \pi \times S \text{ (rpm)}}{1000}$$

V_s = Cutting speed

d = Diameter of workpiece

S = Main spindle speed

The maximum cutting speed depends on

- Material of workpiece:

The higher the strength of the material, the lower the cutting speed.

The charts contain the following data:

V_s = 44 m/min for aluminium (Torrador B)

V_s = 35 m/min for soft steel
soft plastics

V_s = 25 m/min for tool steel
hard plastics

- Material of tool:

Carbide tools allow higher cutting speed than HSS tools.

The values given in the charts are for HSS tools.

7.1.2 Speed (S)

You calculate the speed of the milling spindle from cutting speed and diameter of milling cutter.

$$S \text{ (rpm)} = \frac{V_s \text{ (m/min)} \times 1000}{d \text{ (mm)} \times \pi}$$

7.1.3 Feed rate and depth of cut

F = Feed rate (mm/min)

t = Depth of cut (mm)

Generally: feed rate and depth of cut depend on

- workpiece material
- performance of machine and
- geometry of milling cutter.

Material of workpiece:

The higher the strength, the lower the F and t values.

Rating of the machine

The higher the rating, the greater the feed and the depth of cut (limitations: cutter geometry).

The tables gave guide values for the F1-CNC.

Relationship between F and t :

The bigger t is, the smaller F is and vice versa.

7.2 Determining the feed rate and depth of cut during milling

7.2.1 Face milling of aluminium (Torrador B) at $v = 44$ m/min

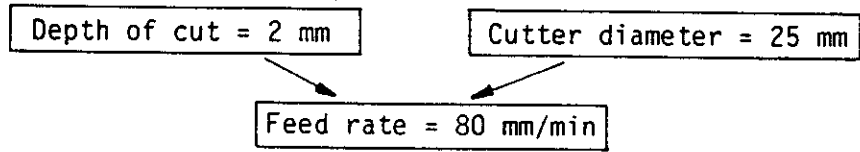
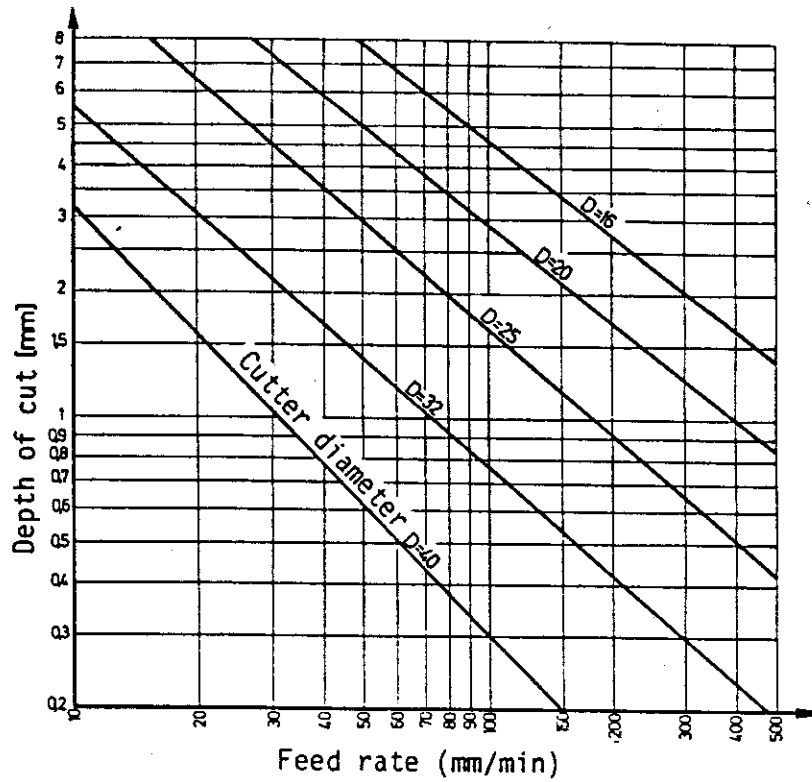

You can also proceed as follows:

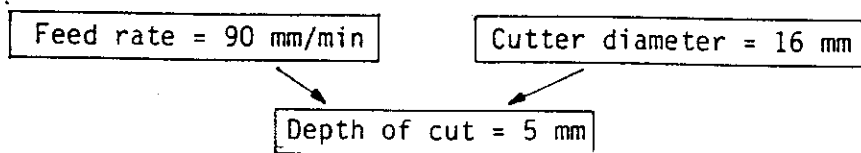

7.2.2 Face milling of steel (9S20) at $v = 35$ m/min

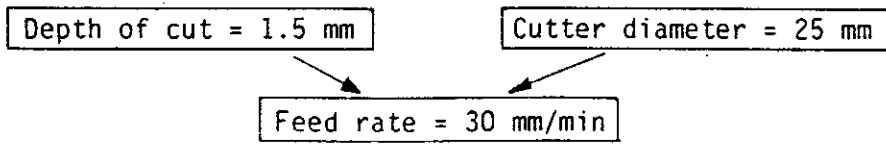
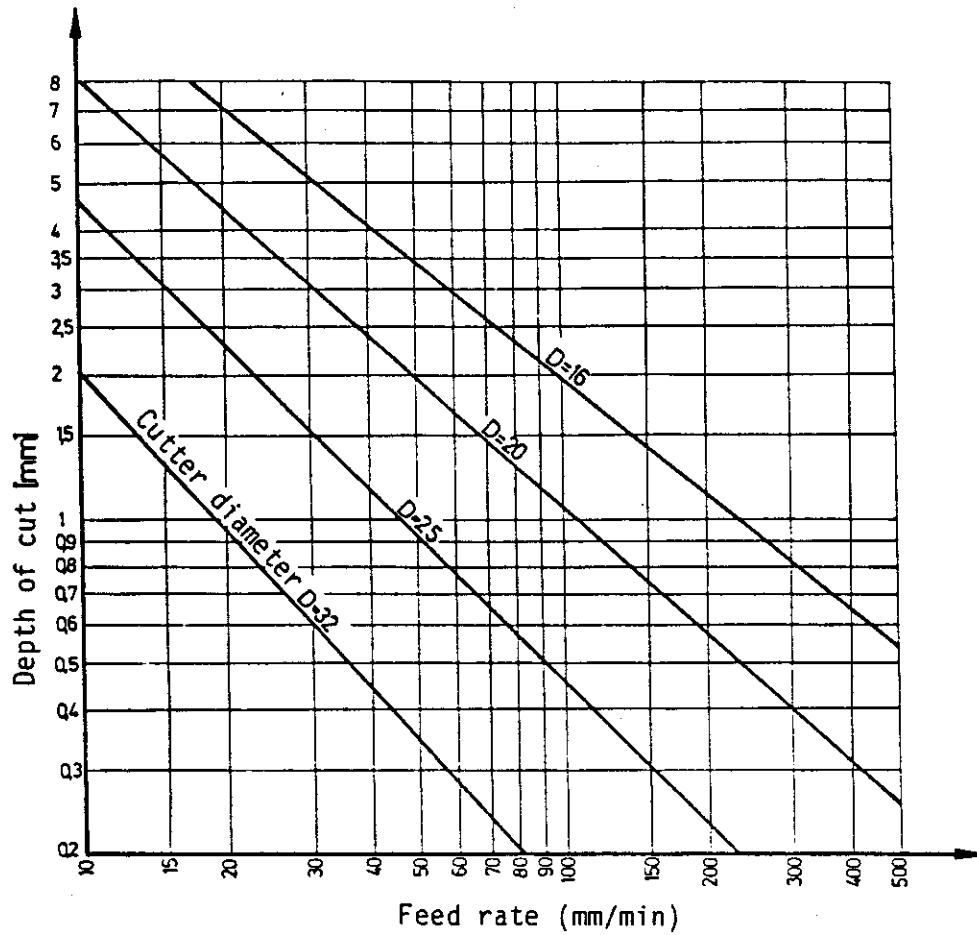

You can also proceed as follows:

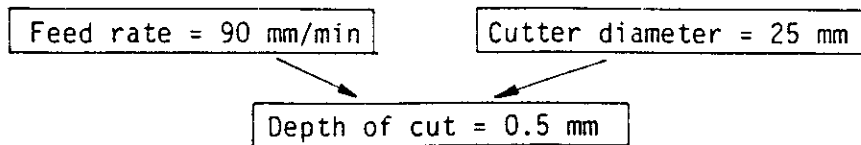

7.3 Determining the feed rate
during drilling in 9S20 and Torratur B

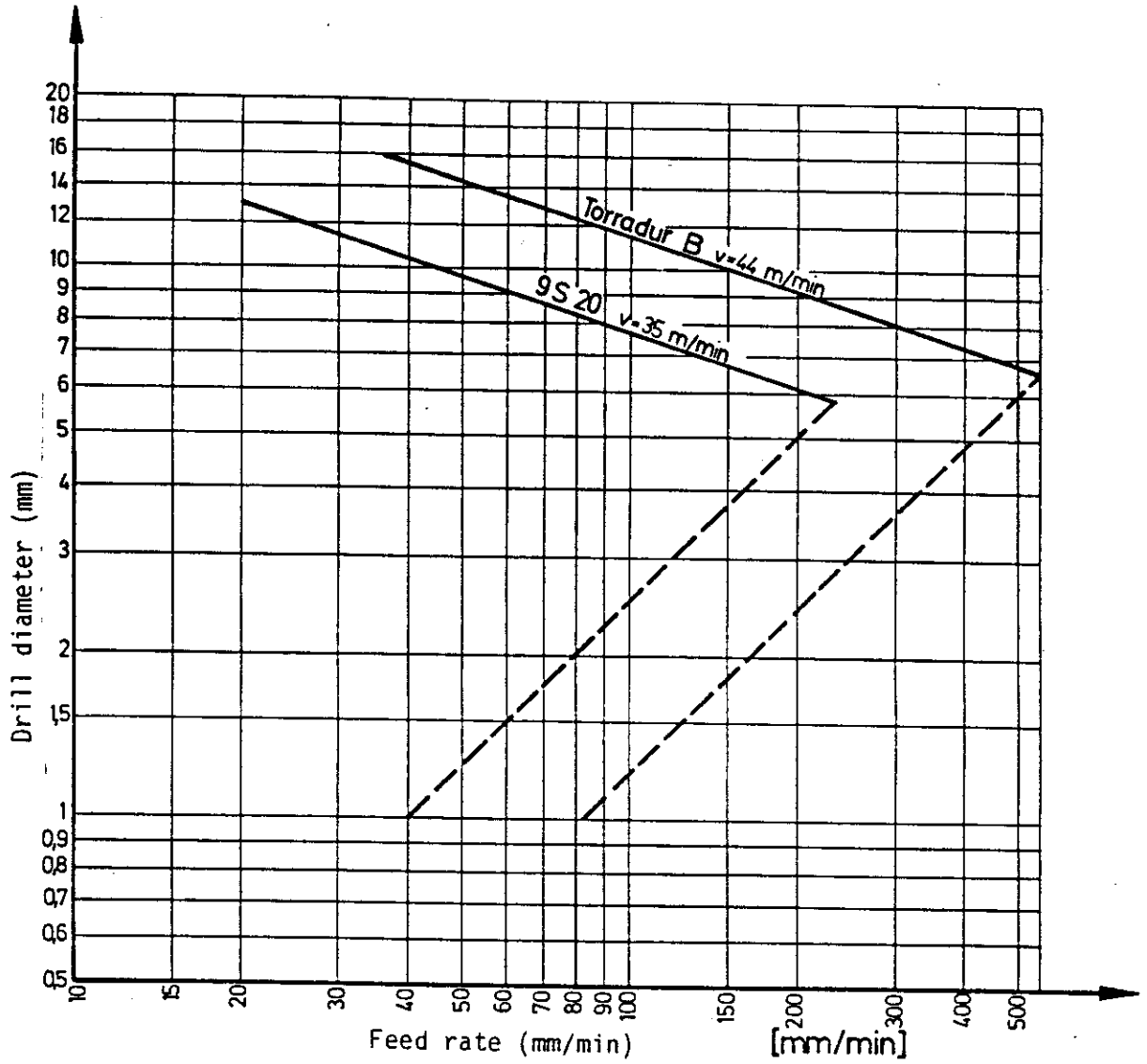

Material: 9S20

Drill diameter = 9 mm



Feed rate = 60 mm/min

7.4 Determining the speed and cutting speed

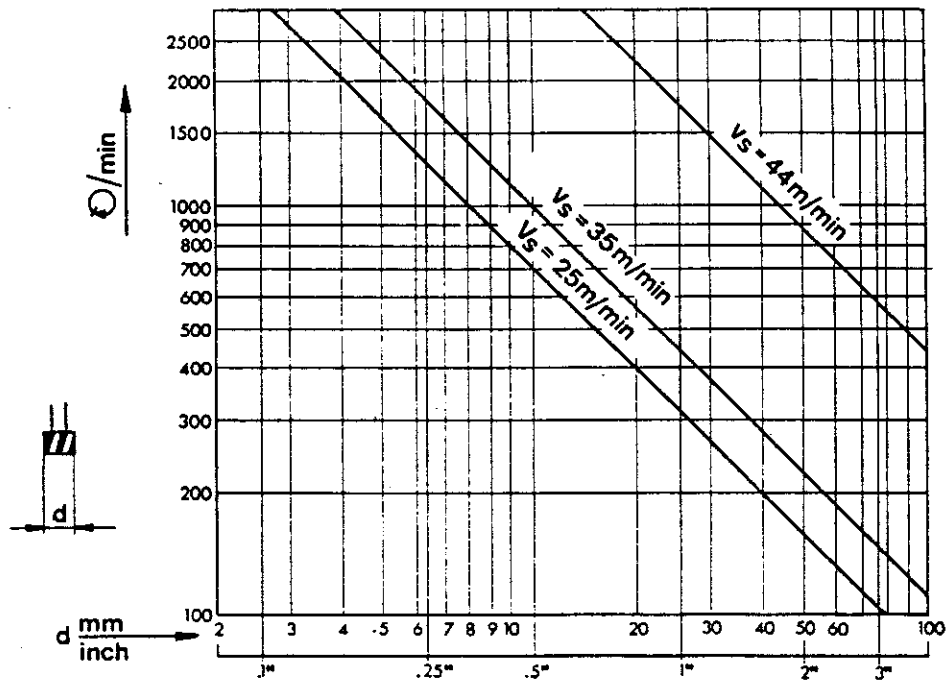

Determining the cutting speed:

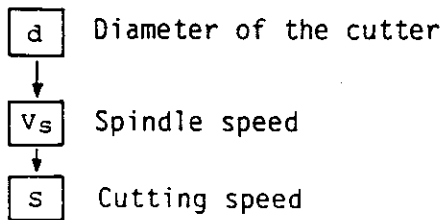

Determining the speed:

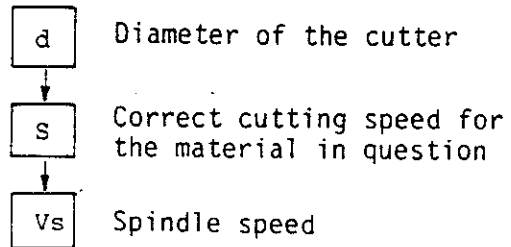

8. Lubrication of the machine

Lubricant recommendations

Lubrication of the Machine

Lubricant recommendations

Lubricant recommendations

1. Slideways

Oil the guideways of the longitudinal, cross and vertical slides every day with oil press. (One lub. nipple on the vertical slide, two nipples on the left under the longitudinal slide).

Oil for slideways

Slideway oil with adhesion additives and wear-reducing additives. Prevention of the stick-slip effect. $73 \text{ mm}^2/\text{sec. (cSt)}$ at reference temperature 40° .
CASTROL MAGNA BDX 68.
Complies with the Cincinnati Milling Specification P 47.



2. Feed spindles X, Y, Z:

The spindles installed in the machine have permanent grease lubrication. If a new spindle is installed, it is to be greased.

Grease grade

Lithium-saponified multipurpose grease with a high drip point. Penetration about 285. NLGI class 2.
CASTROL SPHEEROL EPL 2.
This grease has a service temperature range of -30°C to $+110^\circ\text{C}$.

or

CASTROL GREASE LM -
lithium-saponified multipurpose grease of the NLGI class 2.

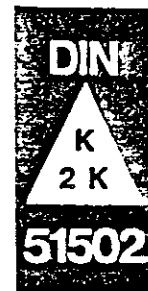
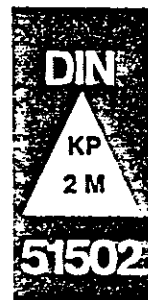

8. Lubrication of the machine

Lubricant recommendations

3. Main spindle bearings:

The main spindle bearings installed have permanent grease lubrication.

If the main spindle bearings are replaced, the two covers and the two tapered roller bearings are to be greased with depot grease (quantity: about 4 cm³).

Grease grade:

Arcanol anti-friction bearing grease L74

DIN 51502

KTBLE2K consistency NLGI 2.

This is a special grease from FAG (bearing manufacturer).

It has a temperature range of -40°C to +130°C and is water-resistant.

9. Readjustment Work

- 9.1 Inspection of the main motor carbon brushes
- 9.2 Readjustment of the milling head limits
- 9.3 Removal and fitment of the main motor
- 9.4 Replacing the main spindle bearing
- 9.5 Exchanging the step motors
- 9.6 Exchanging the X-, Y-, Z-spindles
 - 9.6.1 Removal of the X-spindle
 - 9.6.2 Removal of the Y-spindle
 - 9.6.3 Removal of the Z-spindle
 - 9.6.4 Installation of the spindles
- 9.7 Readjustment of the slide clearance
- 9.8 Measuring the reversal clearance
- 9.9 Seizure of the tool

9.1 Inspection of the main motor carbon brushes

Disconnect the mains plug, prior to inspection of the carbon brushes.

Worn carbon brushes damage the armature laminations, and can destroy the main spindle pc-board due to excessive brush sparks.

Inspecting the carbon brushes

Interval: Every 100 operating hours.

A new carbon brush has a length of about 20 mm. The carbon brush must be replaced, at the latest, when the remaining length is about 6 mm.

Uneven wear is a typical characteristic of a direct current permanent motor that turns in one direction.

Exchange the unevenly worn carbon brushes insofar as they still have sufficient length.

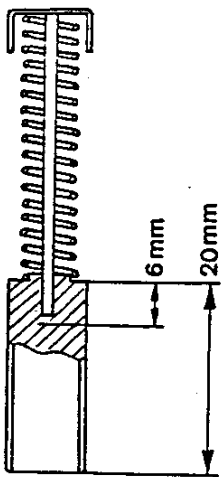

9.2 Readjustment of the milling head limits

Where the milling head is improperly swivelled at the limits, deformation of the limit bolt can occur. The limit can be readjusted.

Readjustment:

Clamp a mandrel (1) in the collet, and measure angularity with gauge or angle (2).

Reset the limit bolt accordingly.

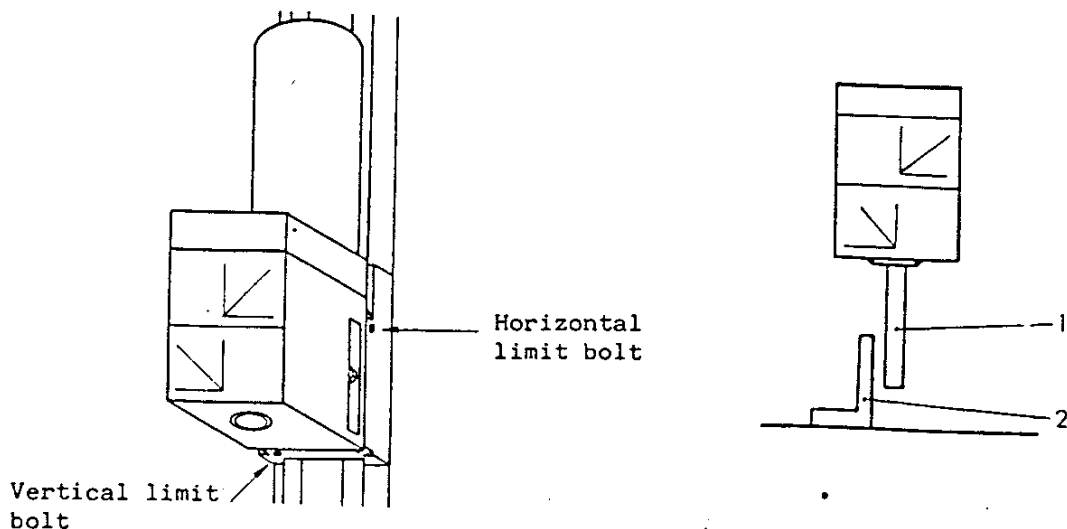

9.3 Removal and fitment of the main motor

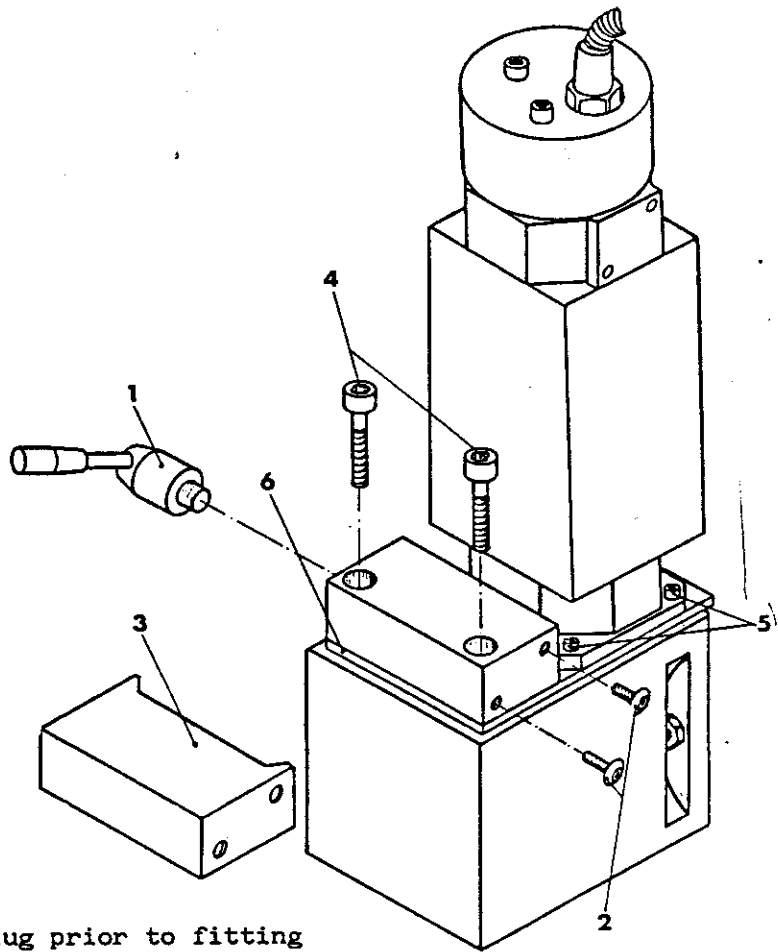

Note:

Disconnect the mains plug prior to fitting or removing the main motor!

Removal:

- Remove the rear machine panel
- Disconnect the main motor cable from the terminal strip
- Unscrew the cable screw union, unthread the cable and remove the hose.
- Unscrew lever (1) (counter-clockwise thread)
- Unscrew the cheese-head screws (2) left and right of the cover (3), and remove the cover.
- Unscrew both hexagonal socket head screws of the eccentric block (4) and remove the eccentric block.
- Unscrew the 4 fixing screws (5) of the main motor, and remove the main motor with motor plate (6) and drive belt.

Fitment:

- Place motor plate on motor
- Place V-belt on pulley
- Place motor with motor plate and positioned belt on milling head (pretensioning force for clamping the main motor belt 6.5 kp (65 N)).
- Unscrew the main motor with motor plate (taking into account the V-belt tension) with milling head.
- Fit eccentric block
- Fit cover
- Screw on lever
- Thread in cable, fit hose, screw on cable screw union.
- Connect main motor cable (see electrical connection of the main motor, next page).
- Fit back panel

Electrical connection of the main motor

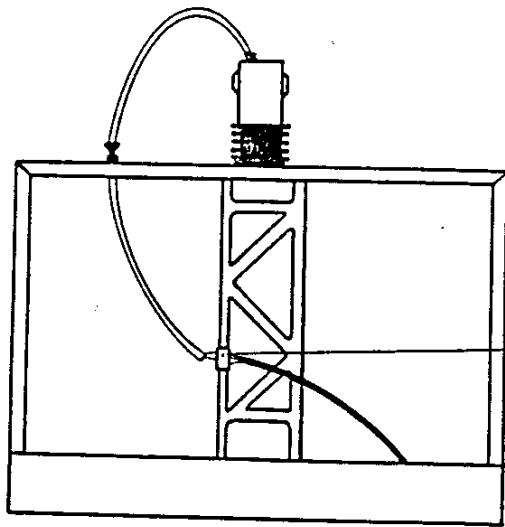

- + Back panel removed.
- + Install cable.
- + Screw cable screw union.
- + Connect cable of main motor.
- + Attach back panel.

Terminal strip

Connection cable
Main motor

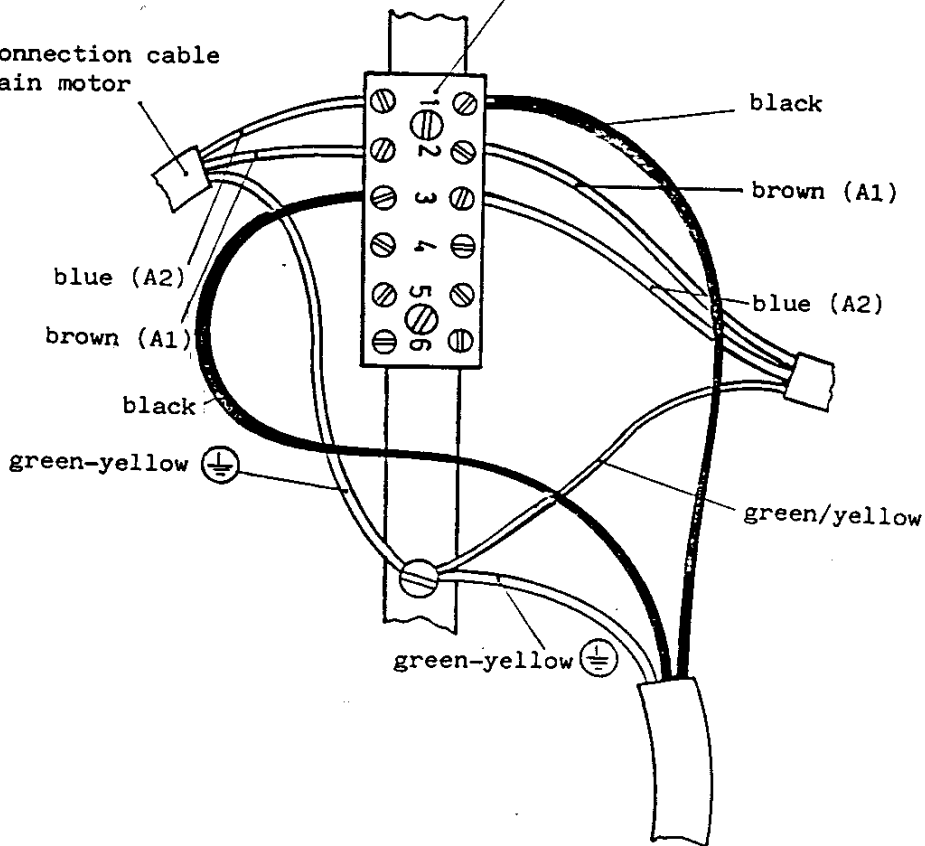

9.4 Replacing the main spindle bearing

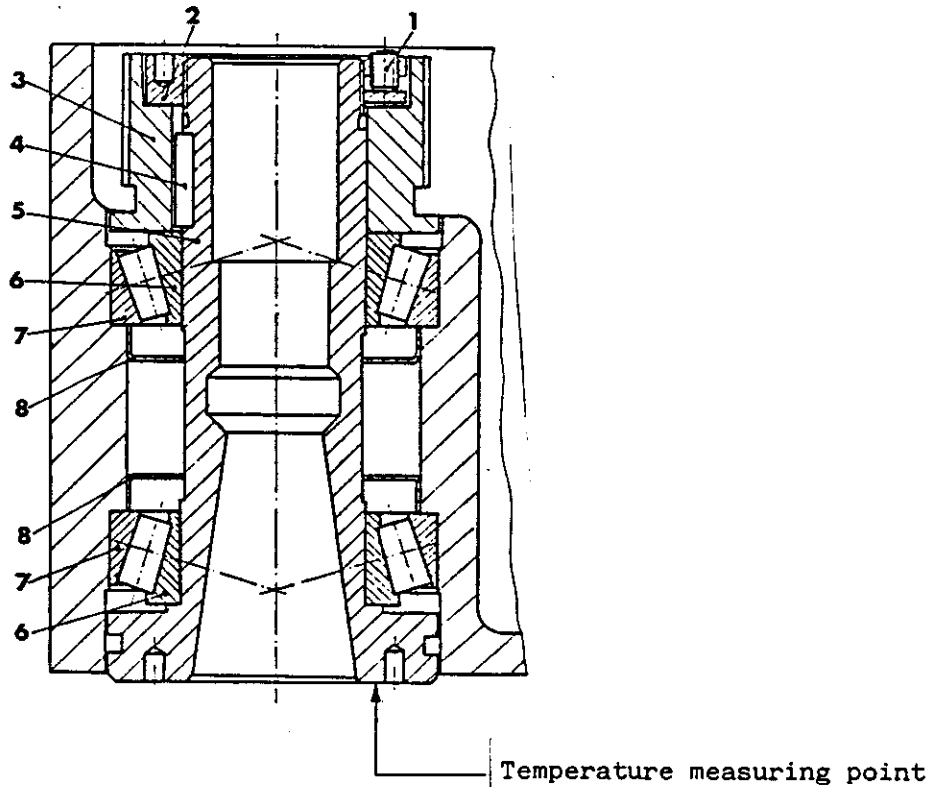

Removal:

- + Disconnect mains plug.
- + Remove main motor.
- + Unscrew tapped stud (1).
- + Unscrew annular nut (2).
- + Remove pulley (3).
- + Remove adjusting spring (4).
- + Knock the spindle (5) out downwards (with plastic hammer).
- + Remove the internal bearing rings (6) and the external bearing rings (7).

Lubricating the bearing

Half fill the 2 covers with grease (depot grease, quantity 4 cm³).

Grease the tapered roller bearings.

Grease quality:

Arcanol Roller Bearing Grease L74
DIN 51502 KTBLE2K consistency
NL GI2 (Messrs. FAG)

Fitment:

- + Top-up the depot grease of the bearing covers (8) (quantity 4 cm³).
- + Press the external bearing rings (7) into the milling head.
- + Press the lower internal bearing ring (6) on the spindle.
- + Insert spindle and press on the upper internal bearing ring (6).
- + Fit adjusting spring (4).
- + Attach pulley (3).
- + Tighten annular nut (2).
- + Adjust the annular nut (2) until the main spindle bearing is pretensioned without clearance. (Tap with a plastic hammer on the main spindle, to avoid tensioning of the spindle and to permit clearance-free pretensioning.)
- + Tighten the tapped stud (1).
- + Attach main motor.
- + Carry out trial run and check rise in temperature (see next page).

The trial run for the F1 P-CNC
consists of five phases

Allow the spindle bearing to cool down to room temperature between the individual phases.

Trial run:

Phase No.	Time	% of max. speed	Speed
Phase I	1. 15 min.	16.6 %	660 (rpm)
	2. 15 min.	33.3 %	1330 (rpm)
	3. 15 min.	50 %	2000 (rpm)
Phase II	1. 15 min.	33.3 %	1330 (rpm)
	2. 15 min.	50 %	2000 (rpm)
	3. 15 min.	66.6 %	2660 (rpm)
Phase III	1. 15 min.	50 %	2000 (rpm)
	2. 15 min.	66.6 %	2660 (rpm)
	3. 15 min.	75 %	3000 (rpm)
Phase IV	1. 15 min.	50 %	2000 (rpm)
	2. 15 min.	75 %	3000 (rpm)
	3. 15 min.	100 %	4000 (rpm)
Phase V	1. 15 min.	50 %	2000 (rpm)
	2. 15 min.	75 %	3000 (rpm)
	3. 15 min.	100 %	4000 (rpm)

The temperature should not exceed 60°C.
With higher temperatures, the bearing is excessively pretensioned.

9.5 Exchanging the step motors

The groups for X-, Y- and Z-step motors are different. A step motor group consists of step motor, encoder and motor plate.

X- and Z-slides are additionally equipped with cable screw unions and hose.

The motor plates of the individual groups are different.

Note:

Disconnect the mains plug, prior to fitting or removing the step motors!

Removing the step motors

- Disconnect plug from control
- Unscrew back panel from machine
- Remove and open cable clamp
- Remove the particular cable of the step motor from the cable line.
- Open the cable screw union of the particular step motor (only with X and Z) toward the machine side.
- Unthread the cable
- Remove step motor with motor plate (with X-motor, remove the V-belt protective cover to ease assembly).

Fitting the step motors

- + Attach V-belt and screw on motor with motor plate. Do not tighten the screws as yet.

Tensioning the V-belt

- + Pressure on motor for V-belt tensioning about 3 kp (30 N). Where the belt is excessively tensioned, wear is accelerated. With insufficient tension, the V-belt jumps over the teeth - shearing of the teeth, tearing is the consequence.
- + Tighten the screws.
- + On X-motor, fit belt cover.
- + On X, Z-motor fit cable screw union.
- + Place cable in cable sheath and close the cable sheath.
- + Fit cable line in cable clip.
- + Fit clip.
- + Adjust tacho-generator (see next page)
- + Fit back panel.
- + Connect plug to control.

Adjusting the tachogenerator

When adjusting the tachogenerator, ensure that the distance between the bolt (1) and the tachogenerator (2) is correct.

This distance is 0.3 - 0.5 mm.

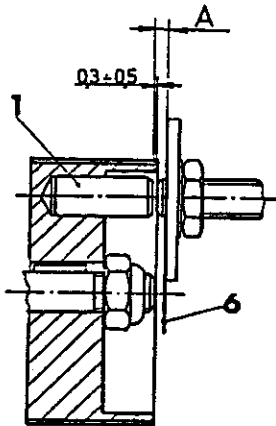

Adjusting procedure

- + Measure distance assembly level for motor plate (6) to front side of the bolt (1) (Dimension A).
- + Adjust tachogenerator on motor plate so that the distance between bolt-tachogenerator is 0.3 - 0.5 mm.

X, Z-tachogenerator

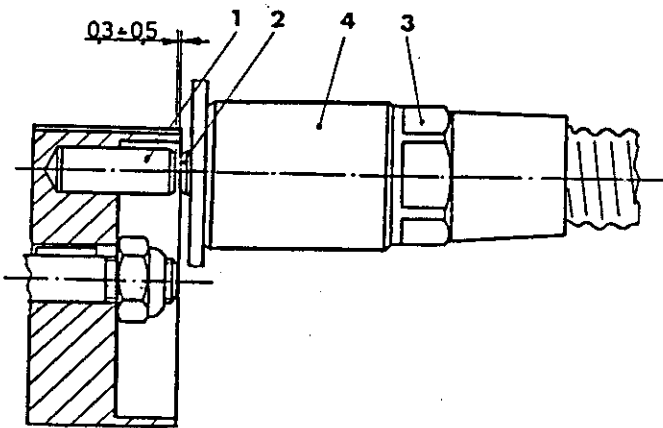

- Unscrew cable screw-union (3).
- Screw back the spacer sleeve (4), so that the tachogenerator (2) can be reached.
- Adjust the tachogenerator to the correct distance, and counter with spacer sleeve.
- Screw on cable screw union.

Y-tachogenerator

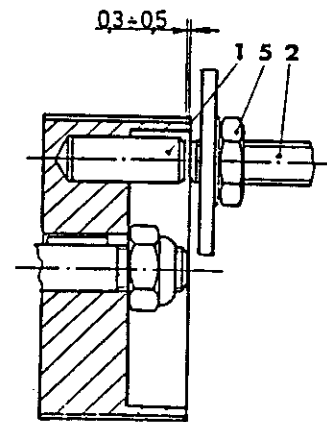

- Loosen nut (5) and adjust the tachogenerator (2) to correct distance.
- Counter the tachogenerator again.

Function check of the tachogenerator

Approach the reference point, and carry out trial programme.

9.6 Replacing the X-, Y-, Z-spindles

The spindles are only replaced as a group. X, Y, and Z groups are different. The group consists of the spindle, nut mount, bearing pedestal and pulley (see Spare Parts List). With the bearing and mounting, ensure that the spindles are not bent.

Under no circumstances may the spindles be screwed on by the nuts, since this will cause the balls to fall out.

Removal:

General:

Dismantle the particular step motor with the motor plate. On the X step motor, additionally dismantle the belt protection first.

9.6.1 Removal of the X-spindle

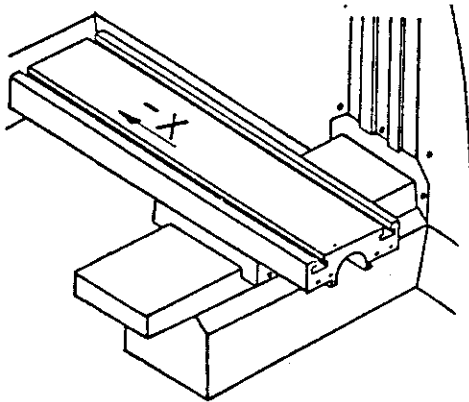

To simplify spindle disassembly, traverse the X-slide as far as possible in the X-direction.

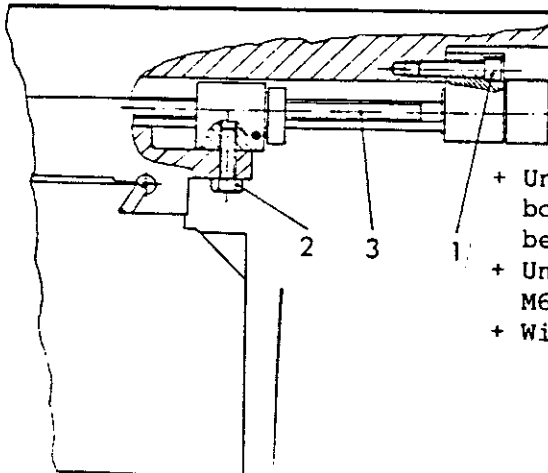

- + Unscrew the cheese-head bolts M5 x 25 (1) on the bearing pedestal.
- + Unscrew the hexagonal bolts M6 x 12 (2) for the nut mount.
- + Withdraw the spindle (3).

9.6.2 Removal of the Y spindle

Note:

To simplify spindle disassembly, traverse the Y slide as far as possible in the Y direction.

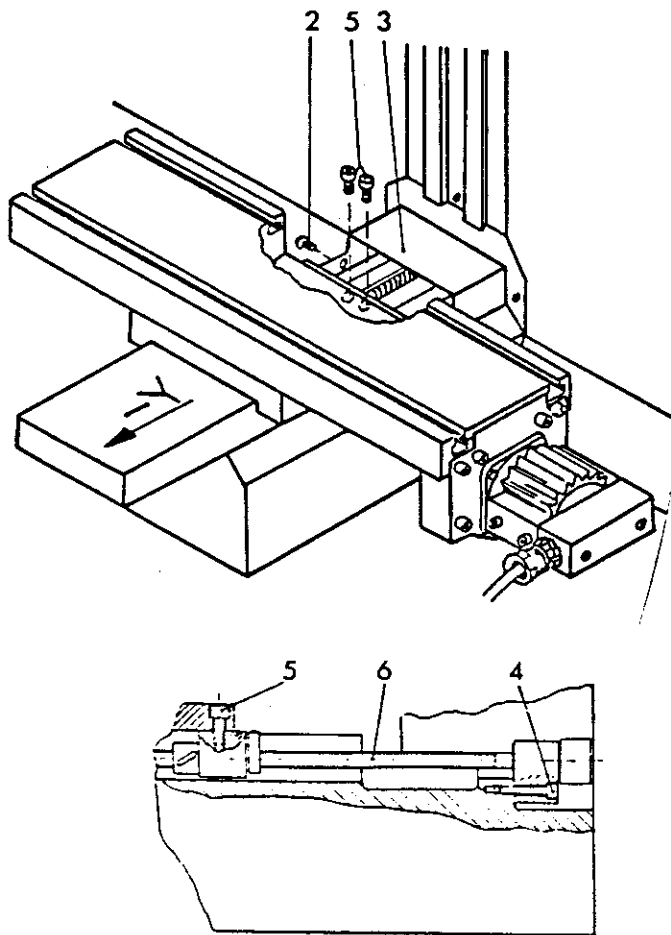

- + Remove back panel.
- + Unscrew the oval-head bolts M6 x 10 (2) for protective sheet 2 (3) and push back the protective sheet.
- + Unscrew the cylinder bolt M5 x 25 (4) on the bearing pedestal.
- + Unscrew the cheese-head screws M6 x 12 (5) for nut mount.
- + Pull out spindle (6).

9.6.3 Removal of the Z-spindle

Note: When the step motor of the Z spindle is removed, the vertical slide could slip away (the ball circulating spindles are not self-locking).

For this reason, securely support the vertical slide in the upper position, prior to disassembly of the step motor (also installation aid).

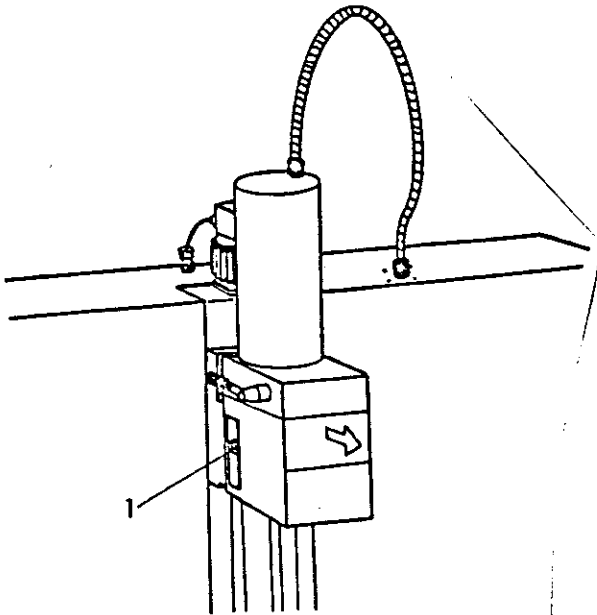

- + Disassemble the milling head with main motor (unscrew the hexagonal nuts M8 (1) and pull off the milling head).
- + Deposit the milling head so that no damage can occur.

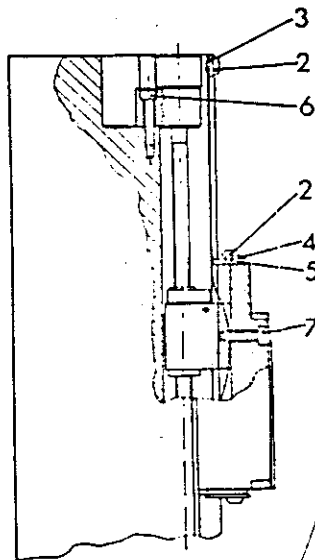

- + Unscrew the oval-head bolts M6 x 10 for holding plate 2 and remove the holding plate (3).
- + Unscrew the oval-head bolts M6 x 10 for scraper plate (2) and remove the scraper plate (4) with scraper felt (5).
- + Unscrew the cheese-head bolts M5 x 25 (6) for bearing pedestal.
- + Unscrew the cheese-head bolts M6 x 20 (7) for nut mount and pull out the spindle.

9.6.4 Installation of the spindles

Prior to installation, grease the spindles with Arcanol Roller Bearing Grease L74 DIN 51502 KTBLE2K, consistency NLGI2 (Messrs. FAG).

Installation of the spindles

The spindles may not be tensioned during installation.

Consequences of tensioned spindle installation

Rapid wear, damage (the balls break out).

Possibilities of tensioning with the X spindle as an example

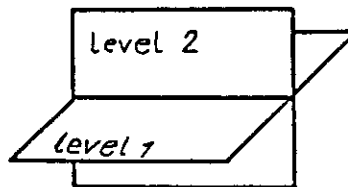

Tensioning in level 1
(plan view)

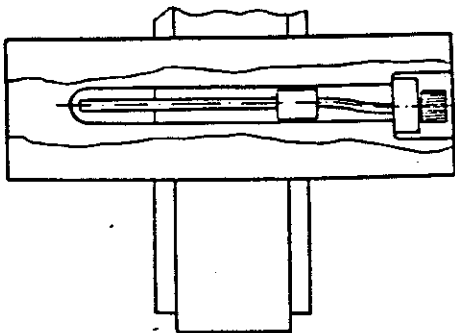

Spindle side tensioned

Tensioning in level 2
(front elevation)

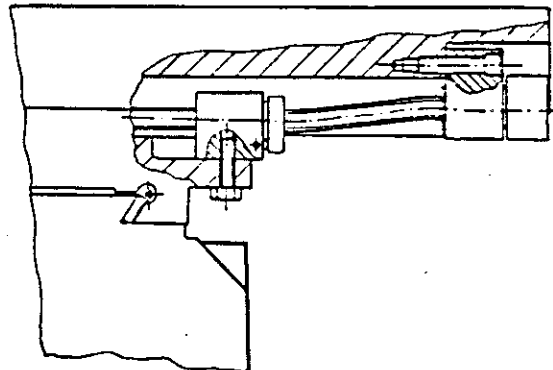

Spindle tensioned at elevation

To prevent tensioning of the spindles during installation, the following procedure generally applies

(X spindle example)

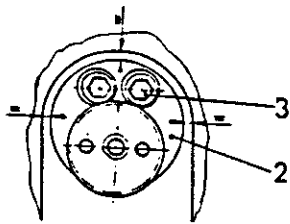

- + Thread spindle, screw bearing pedestal (2) with cheese-head bolts M5 x 25 (3) firmly, so that it is centrally placed in the milling out.

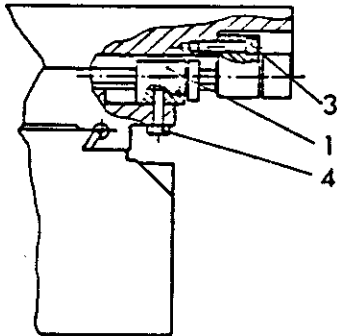

- + Screw the nut mount (1) with the hexagonal bolts M6 x 12 (4) firmly. Move slide or adjust nut mount so that it can be fastened with the hexagonal bolts.
- + Crank the slide completely to the right. Keep the distance between the nut mount - bearing pedestal, as small as possible.

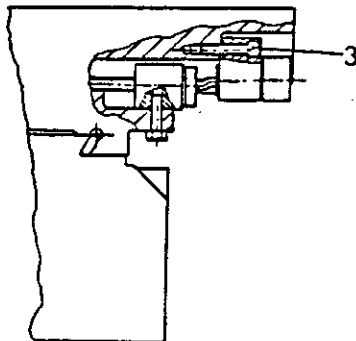

It is now possible that the spindle is tensioned in the elevation (level 2).

Remedy:

- + Loosen the bearing pedestal hexagonal socket head screws (3), which will cause the spindle to align itself in level 2.

Retighten the cheese-head bolts (3) of the bearing pedestal.

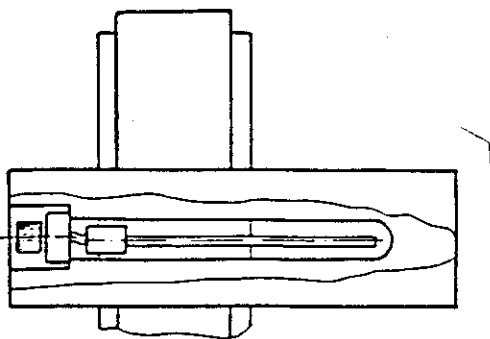

Plan view

Possibility:

Spindle tensioned in level 1.

Therefore:

- + For safety, again loosen the bolts of the nut mount, and then retighten. (possible tensioning of the spindle in level 1)
- + Refit the remaining removed parts.

9.7 Readjustment of the slide clearance

- + Readjust the slide guides after extended use.
- + The wear of the guides on the X, Y, Z slides can differ considerably, since the load normally differs on the slides.
- + Slides with excessive clearance, can cause jerking during machining.
- + The clearance is set with two taper gib strips each per slide.

Checking the guide clearance of the X, Y, Z slide

Structure of the gauge:

The slide clearance is measured on both sides of the particular slide, and should not exceed 0.015 mm. During clearance measurement, the slide is swivelled to and fro at the particular measuring point, with a swivel force of 100 N (10 kp).

a) X slide

Gauge on Y slide
(If the gauge were fixed to the base, the Y clearance would also be measured)

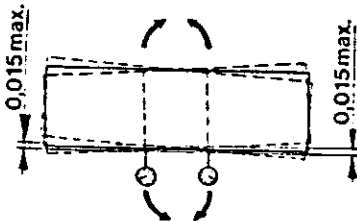
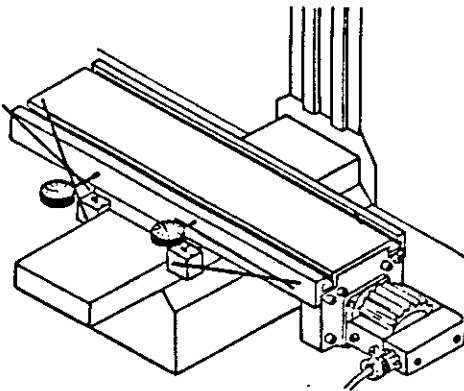

b) Y slide

Gauge on base

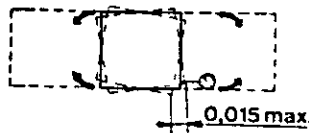
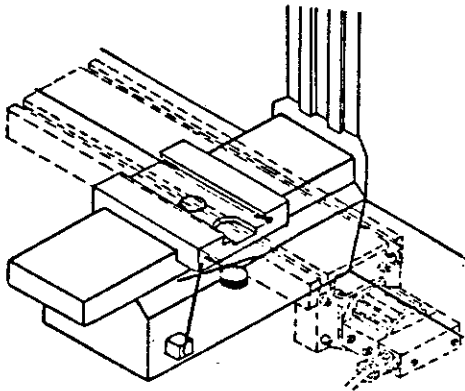

c) Z slide

Gauge on measuring table (remove milling head)

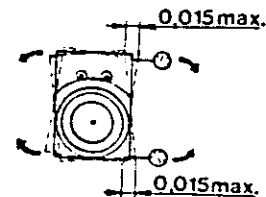
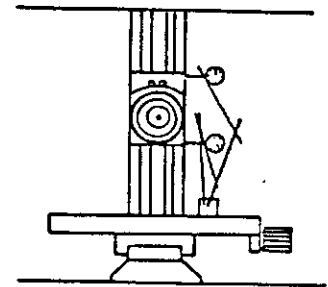

The gauge is only applied at the front, since the slide is guided at the rear by scraper felt.

Readjusting the taper gib strips

The slide clearance is readjusted with the appropriate taper gib strips on the slide.

The guide way of the taper gib strip, as well as the taper gib strip, are conical.

By screwing in the tapped stud (size 2.5), the taper gib strips are moved in the direction of the arrow. The clearance is reduced.

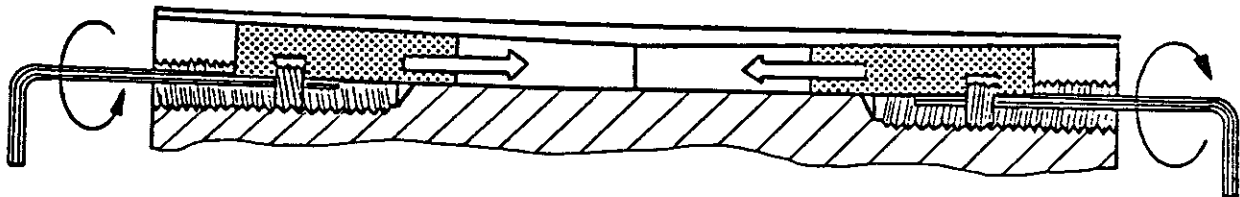

Process:

Readjust the tapped stud slightly.
Measure the slide clearance with a gauge.
Repeat process until the measurement obtained is 0.01 to 0.015 mm.

Attention:

Where the taper gib strips are excessively readjusted, the table will be clamped or will be very difficult to move.

The torque of the step motor could then be inadequate for traversing the slide. The step motor could lose the steps (feed force of the step motor is about 1000 N (100 kp)).

For this reason, unscrew the slide from the appropriate nut mount, and move slide backward and forward by hand (see page 6.18).

Position of the taper gib strips

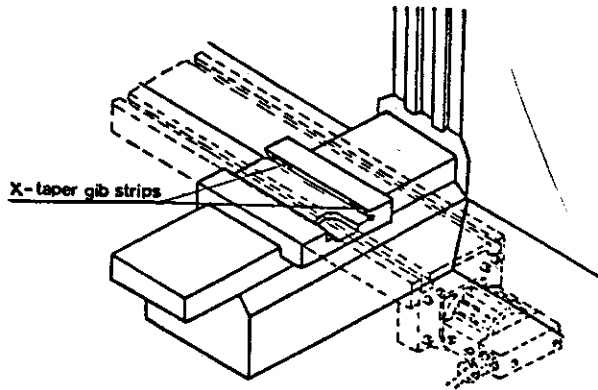

X taper gib strips

The taper gib strips on the X slide are freely accessible.

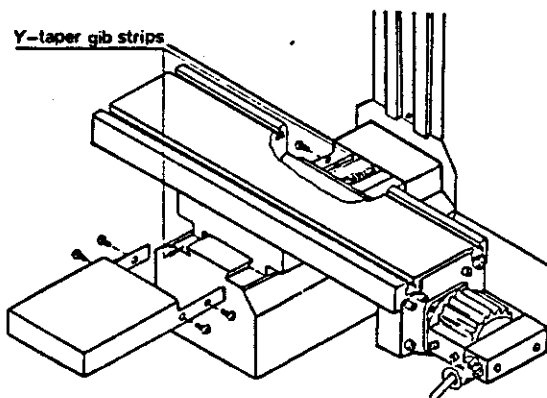

Y taper gib strips

Remove protective plates 1 and 2.

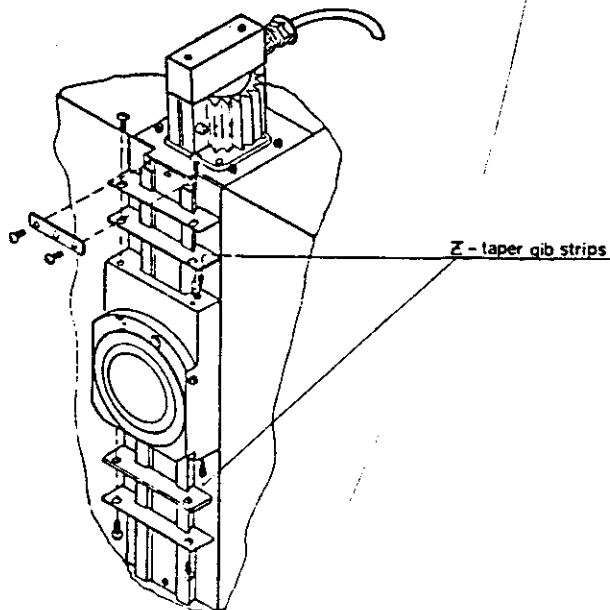

Z taper gib strips

Remove the scraper plates and scraper felts on both sides of the slide.

Removing the nut mount for manual movement of the slide:

To measure the slide clearance, unscrew the slides from the nut mount. Move the slides to and fro by hand. The movement force should not exceed 150 N (15 kp).

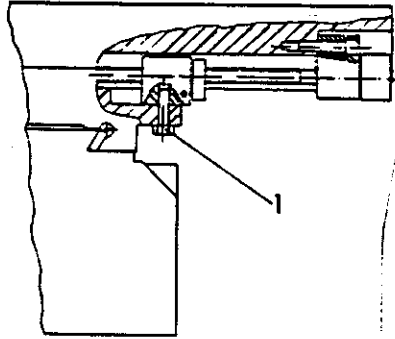

X slide:

Unscrew both hexagonal bolts M6 x 12 (1).

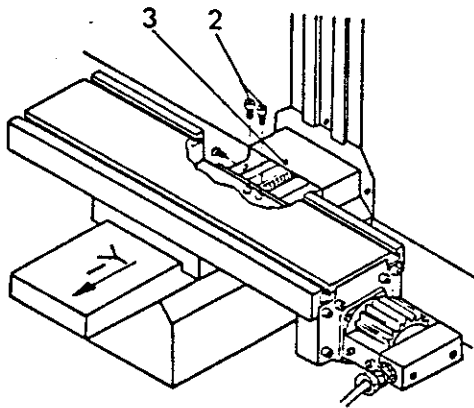

Y slide:

Remove the protective plate 2 (3) and unscrew the hexagonal socket screw of the nut mount (2).

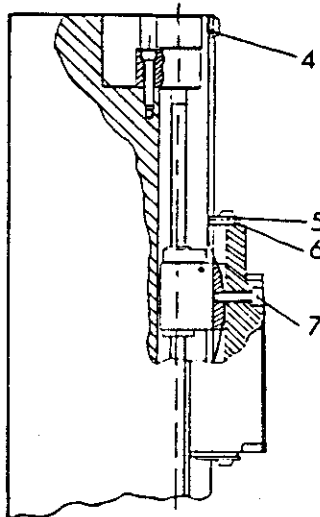

Z slide:

Remove mounting plate (4), scraper plate (5) and scraper felt (6), and then unscrew both hexagonal socket screws of the nut mount (7). (Support Z slide!)

9.8 Measuring the reversal clearance

In addition to the slide clearance, the reversal clearance is important for operating accuracy.

The reversal clearance arises when traversing the slide, e.g. + direction to - direction.

In this case, the control indicates a traverse path, however the slide does not actually traverse (dead path).

The reversal clearance is measured about 5 - 30 mm prior to both the limit positions of the particular slide, and should not exceed 0.08 mm.

Measuring the reversal clearance

- + Fasten gauge with magnetic base.
- + Move slide to gauge.
- + Set gauge at 0.
- + Set display at 0.
- + Move slide about 1 - 2 mm toward the gauge (gauge and display indicate the same traverse path).
- + Move slide with control back to 0.
- + Read off difference (= reversal clearance) on the gauge.
- + Repeat process for the other limit position of the particular slide.

Attention: Relationship slide clearance - reversal clearance

The stronger the setting of the guide strips, the smaller the slide clearance will be, and the larger the reversal clearance.

Accordingly, the slide clearance and reversal clearance must be jointly adjusted. The particular tolerances for slide clearance and reversal clearance, must not be exceeded.

Adjustment of the reversal clearance

You can reduce the reversal clearance by loosening the taper gib (slide clearance gets larger at the same time).

Assembly of the gauge for measuring the reversal clearance of the slide

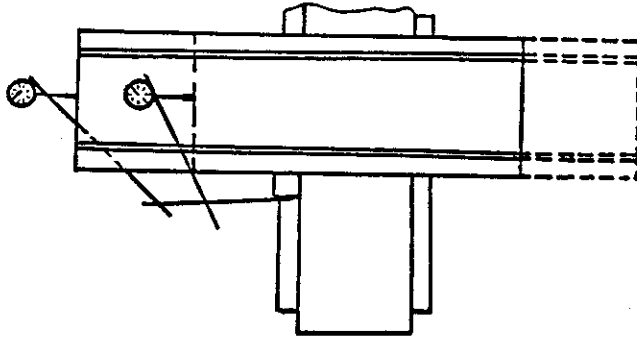

X slide

Gauge on the Y slide

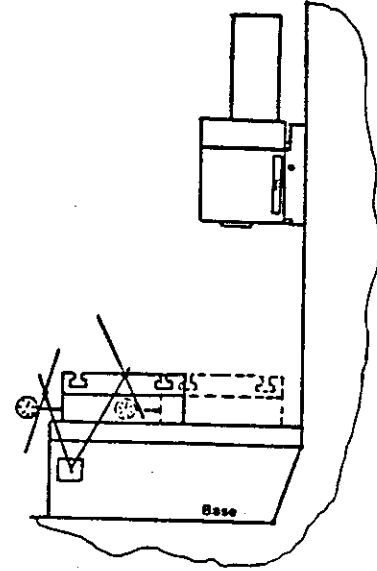

Y slide

Gauge on the base

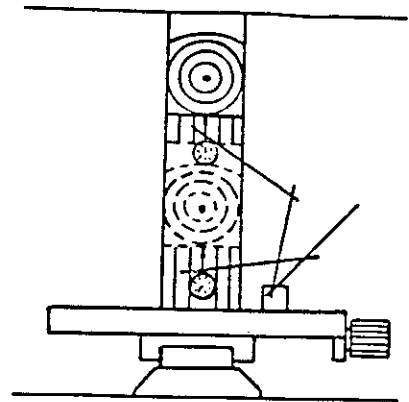

Z slide

Gauge on the table

9.9 Seizure of the tool

Cause:

- + Excessive thermal expansion (the spindle bearing may be excessively pretensioned).

Remedy:

- + Allow tool to cool (possibly cool with compressed air).

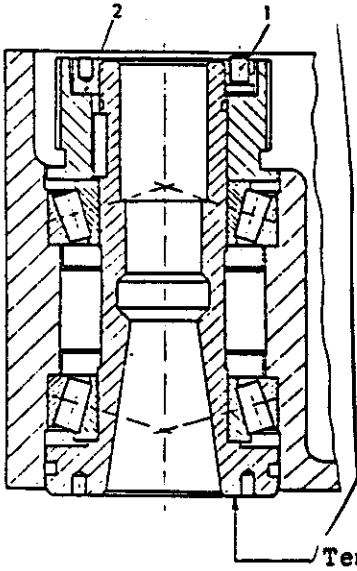

Reduce the bearing pretension:

- + Remove main motor.
- + Loosen tapped stud (1).
- + Slightly loosen the annular nut (2).
- + With a plastic hammer, gently tap on the spindle (so that the excessively pretensioned bearing relaxes slightly).
- + Retighten the tapped stud (1).
- + Refit the main motor.
- + Carry out trial run.

Carry out trial run:

Operate motor for 15 minutes at 2000 rpm. The temperature should not exceed 45 - 50°C.

With higher temperatures, the bearing is excessively pretensioned.

Phase No.	Time	% of max. speed	Speed
Phase I	1. 15 min.	16.6 %	660 (rpm)
	2. 15 min.	33.3 %	1330 (rpm)
	3. 15 min.	50 %	2000 (rpm)
Phase II	1. 15 min.	33.3 %	1330 (rpm)
	2. 15 min.	50 %	2000 (rpm)
	3. 15 min.	66.6 %	2660 (rpm)
Phase III	1. 15 min.	50 %	2000 (rpm)
	2. 15 min.	66.6 %	2660 (rpm)
	3. 15 min.	75 %	3000 (rpm)
Phase IV	1. 15 min.	50 %	2000 (rpm)
	2. 15 min.	75 %	3000 (rpm)
	3. 15 min.	100 %	4000 (rpm)
Phase V	1. 15 min.	50 %	2000 (rpm)
	2. 15 min.	75 %	3000 (rpm)
	3. 15 min.	100 %	4000 (rpm)